

The Mapping of Materials Supply Chains in the UK's Power Generation Sector

CONSULTATION DOCUMENT
<http://www.matuk.co.uk/energy.htm#mapping>

December 2007

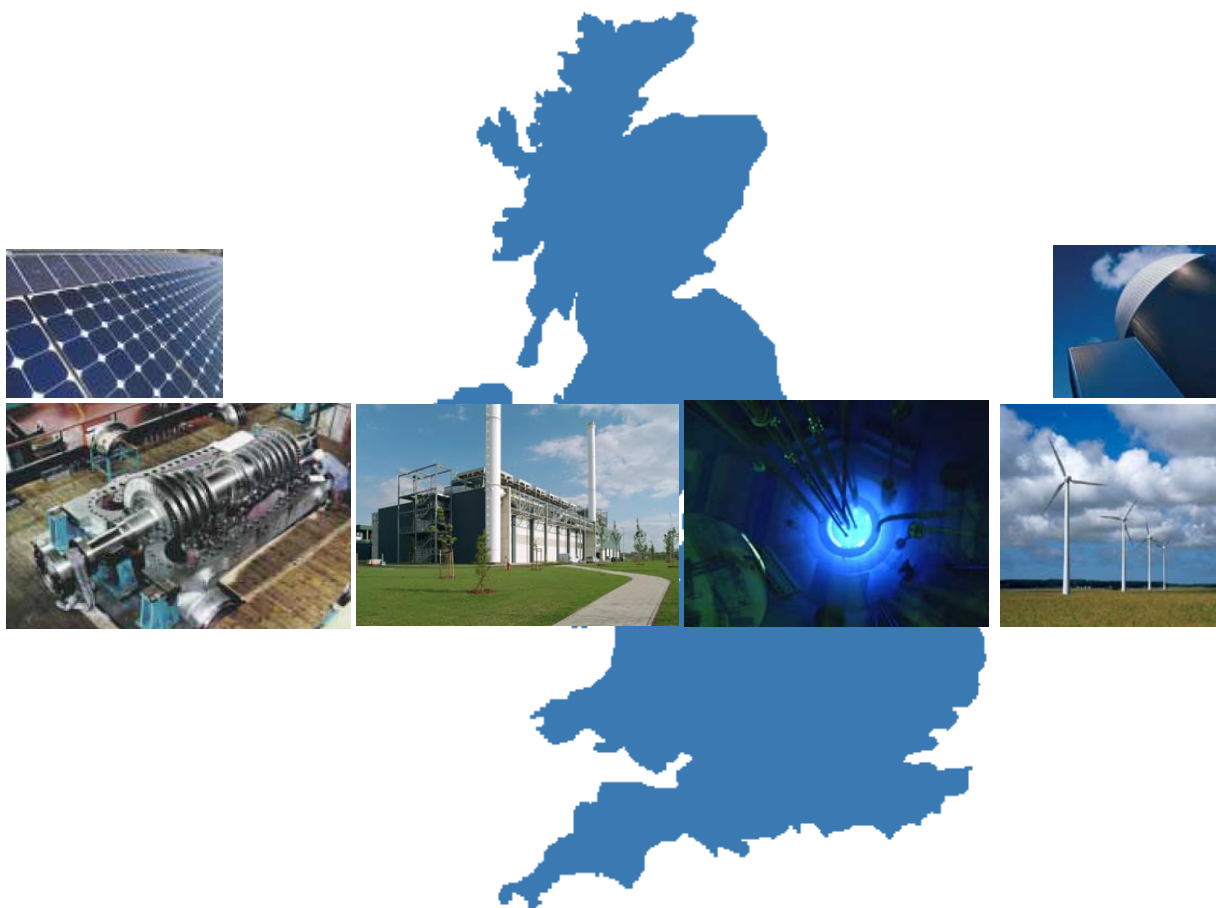

Author

Stephen A. Court NAMTEC

A report to Materials UK by the National Metals Technology Centre (NAMTEC), December 2007.

Care has been taken to ensure that the contents of this report are accurate, but NAMTEC does not accept responsibility for errors or for information which is found to be misleading. Suggestions for, or descriptions of, the use of products or suppliers, or the application of products or methods of working are for information purposes only, and NAMTEC accepts no liability in respect thereof. Before using information contained within this report, the user should make certain that any products supplied by companies listed in this report are suitable for their purpose.

For further information or assistance, please contact:

The National Metals Technology Centre (NAMTEC)
Swinden House
Moorgate Road
Rotherham S60 3AR

Tel: +44 (0) 1709 724990
Email: info@namtec.co.uk



EXECUTIVE SUMMARY

Aims

The major aim of this review was to characterise the markets, strengths and opportunities of the UK's Energy Materials supply chains. Specifically, the review has focused on the application of materials in the generation of electricity by Fossil, Nuclear & Renewable fuels & technologies. Thus, for raw materials suppliers, materials fabricators/manufacturers and OEM's, through to the end users (the utilities or generators), and for each energy source supply chain(s), the major players have been identified.

An additional aim was to highlight some of the significant R&D activities related to materials in power (specifically electricity) generation in the UK. In particular, some of the key organisations and groups/individuals have been identified, as have the major, largely publicly funded, programmes.

Approach

The review has been conducted using primary data gathering from both academic and industrial organisations within the UK and overseas, through a targeted questionnaire and through interviews with representatives from major companies, academic institutions and Research and Technology Organisations (RTOs) - listed at the end of the report. This primary data has also been supplemented with extensive secondary (public domain) data gathering.

Summary

Materials for Conventional Fossil Fuel Fired and Nuclear Power Generation

The UK power equipment and services sector has a turnover of approximately £30 billion and provides employment for approximately 300,000 people in the UK. There are tens of thousands of companies active in this area, the largest of which are amongst the UK's leading companies. Exports of equipment have averaged approximately £1.9 billion a year in recent years, and it is estimated that the inclusion of power related services (which are broken down separately in the trade statistics) would double this figure (information taken from a Mott MacDonald Report for UK Trade & Investment, 2007).

In general, the supply chains for materials used in the manufacture of power equipment/plant for fossil-fired and nuclear power generation have been eroded over the past 10-15 years, and there are some components which UK based companies cannot now supply. For example, forgings for civil nuclear pressure vessels, steam generators and the largest steam turbine rotors. There are also supply chain issues related to nuclear grade graphite and alloys for fuel containment.

According to some estimates, since 1990, the UK has lost some 70% of the supply chain for components and plant for power generation. Reduced domestic demand has forced suppliers to seek alternative markets, and the materials supply chains for fossil-fired plant are reliant upon 'inputs' from mainland Europe, in particular, although materials are also sourced in Japan and the USA.

However, in addition to an OEM capability for large steam turbines, UK based companies also offer an extensive steam turbine service capability (repair, refurbish, upgrade, retrofit, etc.), such that of the world's four largest manufacturers of steam turbines, two maintain significant capability in the UK.

Also, there are two UK based OEMs for land based gas turbines, which together serve the full range of power output requirements for simple cycle or Combined Cycle Gas Turbine (CCGT) applications.

UK based companies maintain an extensive capability in the processing and fabrication of precision components for major fossil fuel fired plant (steam and gas turbines, pulverised fuel boilers, etc.), and could increase supply into this market, if the business conditions were favourable.

However, although a significant capability to manufacture components such as rotors, blades, discs, rings, casings, etc. for fossil-fired power generation exists, few UK based metals processors (eg, caster, forger, extruder, roller, etc.) now have the power generation sector as their major market (say 20% or more of turnover).

The gaps in the UK based materials supply chain for fossil fired power plant include a lack of capability in the manufacture of seamless stainless & speciality steel tube for heat exchanger applications in boilers and steam generators, and for future gasifiers and Carbon Capture and Storage (CCS) systems.

Thus, although the UK is home to a world leader in the supply of boiler plant and related equipment, much of the materials inputs (seamless tubes, pipes, etc.) are sourced from overseas.

As the strength of the supply chain has decreased, so the capacity of the industrial and academic base for research and development in materials for fossil-fired power plant has decreased accordingly. However, many R&D activities in fossil fuel fired power generation are world-class, and have an important contribution to make in the development of materials for high efficiency, low emission power plant.

In particular, the UK's world leading materials development associated with aero engines is of significant benefit to industrial gas turbine development, and it is often difficult to separate most research and development activities, both industrial and academic.

Materials for Power Generation from Sustainable (Renewable) Energy Sources

It is likely that during the introduction of sustainable energy technologies, some difficulties will be experienced in obtaining materials from domestic suppliers. In most instances, the market for renewable energy technologies is not yet mature enough to support established supply chains of any size. This may be related to uncertainties regarding the specifics of which materials are required, as much of the technology itself is developmental. Alternatively, the supply chains may be largely non-UK based, as is currently the case for wind turbine generators, for example.

In wind power, although the UK has world-class developers and consultants, there is currently very little manufacturing capacity in the UK and much of the value of wind-power projects goes abroad. . There are no established turbine manufacturers and very few UK companies export components.

However, the UK is home to both wind turbine rotor blade and tower manufacturing facilities of the world's largest wind turbine manufacturer. In addition, there are indications that with the increased commitment to wind power and with the large number of consented wind power developments, that UK based companies are positioning themselves to supply into this market, and there are certainly a considerable number of companies with the capability to do so.

For example, a UK based company is developing world-leading, direct drive turbine generator technology, and a UK based Research and Technology Organisation (RTO), with industrial partners, has developed radar absorbing materials which should see considerable global exploitation in wind turbine applications.

The UK has established itself as an early market leader in marine (tidal stream and wave) power generation with approximately half of the world's current technology developers (approximately 30) headquartered in the UK. In addition, the UK has pioneered the establishment of shared facilities for the testing of wave and tidal devices.

Currently, there are few marine energy devices / technologies which have reached full-scale testing and, of these, the front-runners currently have, and foresee, no immediate materials supply (chain) issues, as construction is largely utilising the UK's existing offshore technologies and know-how.

The UK is very active in R&D for sustainable energy, through such initiatives as SUPERGEN, the Sustainable Power Generation and Supply Programme. This programme is managed and led by the EPSRC, in partnership with other research councils (Biotechnology and Biological Sciences Research Council (BBSRC), Economic and Social Research Council (ESRC) and Natural Environment Research Council (NERC)) and the Carbon Trust. Various consortia are active in wind and marine energy, solar cell development (both conventional and non-conventional, excitonic) and fuel cells; in addition to conventional fossil-fuel fired power generation.

A further area in which the UK has both world-leading manufacturing and research capacity is in fuel cells, and the UK's materials R&D is at the forefront of fuel cell technology, and will continue to be so for the foreseeable future.

More than a hundred companies based in the UK are active in the development of fuel cell technologies, from materials R&D to fuel-cell systems integration. UK based companies in the sector are developing their supply chains as their technologies evolve and the UK is home to a world leader in catalysts and catalysed components for fuel cells.

CONTENTS

1. INTRODUCTION

- 1.1. The UK's Electricity Generation Landscape
- 1.2. Future UK Electricity Generation
- 1.3. UK Capability in Materials for Power Generation
- 1.4. Scope of the Report

2. FOSSIL FUEL-FIRED POWER

- 2.1. The Fossil Fuel-Fired Power Generation Landscape
- 2.2. Summary of Fossil Fuel-Fired Technology and Plant
- 2.3. UK Supply Chain for Boilers & Steam Generators
- 2.4. UK Supply Chain for Steam Turbines
- 2.5. UK Supply Chain for Gas Turbines
- 2.6. Coatings
- 2.7. UK R&D Activity in Fossil Fuel Energy Materials
- 2.8. Summary
- 2.9. SWOT Analysis

3. NUCLEAR ENERGY

- 3.1. The Nuclear Energy Market
- 3.2. The UK's Nuclear Reactors
- 3.3. The UK's Civil Nuclear Energy Industry
- 3.4. Overview of the UK's Nuclear Industry Materials Supply Chain
- 3.5. The Supply Chain for Major Components of a PWR
- 3.6. UK R&D Activity in Nuclear Materials
- 3.7. Nuclear Industries Specialist Skills
- 3.8. Summary
- 3.9. SWOT Analysis

4. WIND POWER

- 4.1. The Wind Power Market Opportunity
- 4.2. The Wind Turbine Market
- 4.3. Structure of the UK Wind Industry
- 4.4. Wind Turbine Technology
- 4.5. UK Wind Turbine Component Supply Chain
- 4.6. UK R&D Activity in Wind Power Materials
- 4.7. Summary
- 4.8. SWOT Analysis

5. WAVE & TIDAL ENERGY

- 5.1. The Wave & Tidal Power Market Opportunity
- 5.2. Wave & Tidal Power Development
- 5.3. Overview of Wave & Tidal Energy Devices
- 5.4. Lead Wave & Tidal Energy Developers and Devices
- 5.5. Wave & Tidal Energy Supply Chain Structure
- 5.6. UK R&D in Wave & Tidal Energy Materials
- 5.7. Summary
- 5.8. SWOT Analysis

6. SOLAR PHOTOVOLTAICS (PV)

- 6.1. The Solar Photovoltaics Market
- 6.2. The Manufacture of Solar PV Systems
- 6.3. The UK Solar PV Supply Chain
- 6.4. UK R&D Activity in Solar PV Materials
- 6.5. Summary
- 6.6. SWOT Analysis

7. ENERGY FROM BIOMASS / BIOFUELS

- 7.1. Brief Overview of the UK's Energy from Biomass Landscape
- 7.2. Selected UK Capability in Biomass / Biofuel Power Plant
- 7.3. Construction of Large Dedicated Biomass Plants in the UK
- 7.4. Selected Materials R&D Activities Related to Biomass Power Generation
- 7.5. Summary
- 7.6. SWOT Analysis

8. FUEL CELLS

- 8.1. The Market Opportunity for Energy from Fuel Cells
- 8.2. Resources for Fuel Cell Technologies & UK Capability
- 8.3. Summary
- 8.4. SWOT Analysis

ACKNOWLEDGEMENTS

1. INTRODUCTION

1.1. The UK's Electricity Generation Landscape

The UK has an installed capacity of approximately 83 GW of electricity generating capacity, which in 2006 generated approximately 394 GWh of electricity. In addition, the UK has a further 5.5 GW of installed electricity generating capacity in the form of Combined Heat and Power (CHP) schemes.

The UK's electricity generation mix is relatively wide, with approximately 36% generated by gas-fired power stations, 37% from coal, 20% from nuclear (including imports of approximately 2%), slightly less than 5% from renewables and the remainder from other sources, such as oil (2006 figures – see Figure 1.1 below). This diversity reduces the UK's dependency on a single fuel type and helps maintain security of electricity supply.

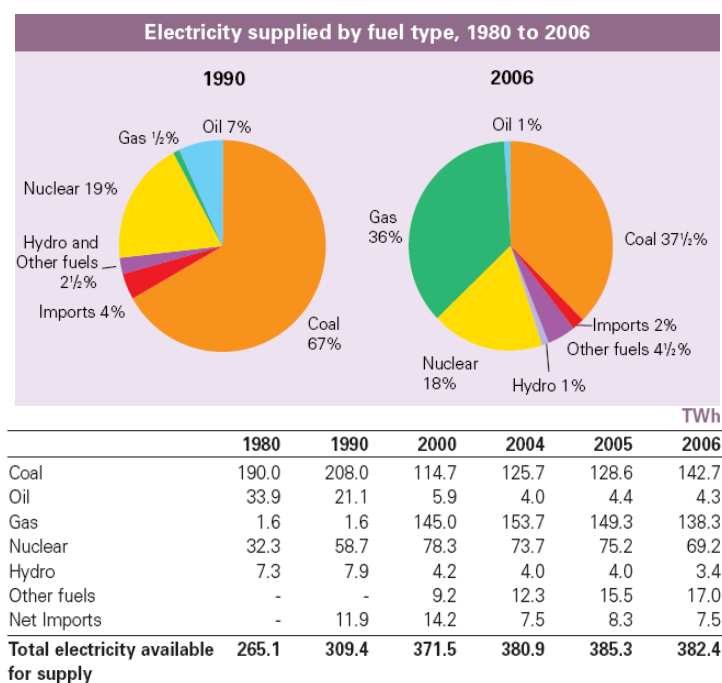

Figure 1.1 - Electricity supplied by fuel type (from: 'UK Energy in Brief, July 2007, BERR).

In 2006, most of the UK's electricity was generated by gas, coal and nuclear stations. Thirty large (>1GW) power stations meet the majority of electricity demand, which is on average approximately 40GW and approximately 60GW at peak. In 2006 (see Figure 1.1):

- Gas provided 36% of electricity, a figure which has grown dramatically from 1% in 1990 and is predicted to grow further. In addition to its use in electricity generation, gas is also used to heat approximately 70% of the UK's homes.
- Coal-fired power stations provided 37.5% of electricity, down from approximately two-thirds in 1990.
- Nuclear power stations provided slightly under one fifth of electricity; but, most existing UK nuclear plants are due to close within the next decade.
- Renewable energy sources provided a relatively small (4.2%), but growing proportion of electricity, which does not include that generated through Combined Heat and Power (CHP) schemes.
- The remainder comes from other sources such as oil fired power stations and electricity imports from the continent.

Relatively few power stations have been built over the past 10-15 years and there is now a need to replace closing coal, oil and nuclear power stations and to meet expected growth in electricity demand. Thus, the UK will need substantial new investment in electricity generation capacity over the next 20 years or so. Thus, approximately 8GW of the UK's coal power stations must close no later than 2015 as a result of EU environmental legislation. And, based on published lifetimes, more than 10GW of the UK's nuclear power stations will close by 2023. In total, the UK is likely to need around 25GW of new electricity generation capacity by 2025, equivalent to more than 30% of today's existing capacity.

Figures 1.2 and 1.3 show the expected capacity to be shut down by 2020 and the new capacity needed to replace the shut-down capacity and meet rising demand.

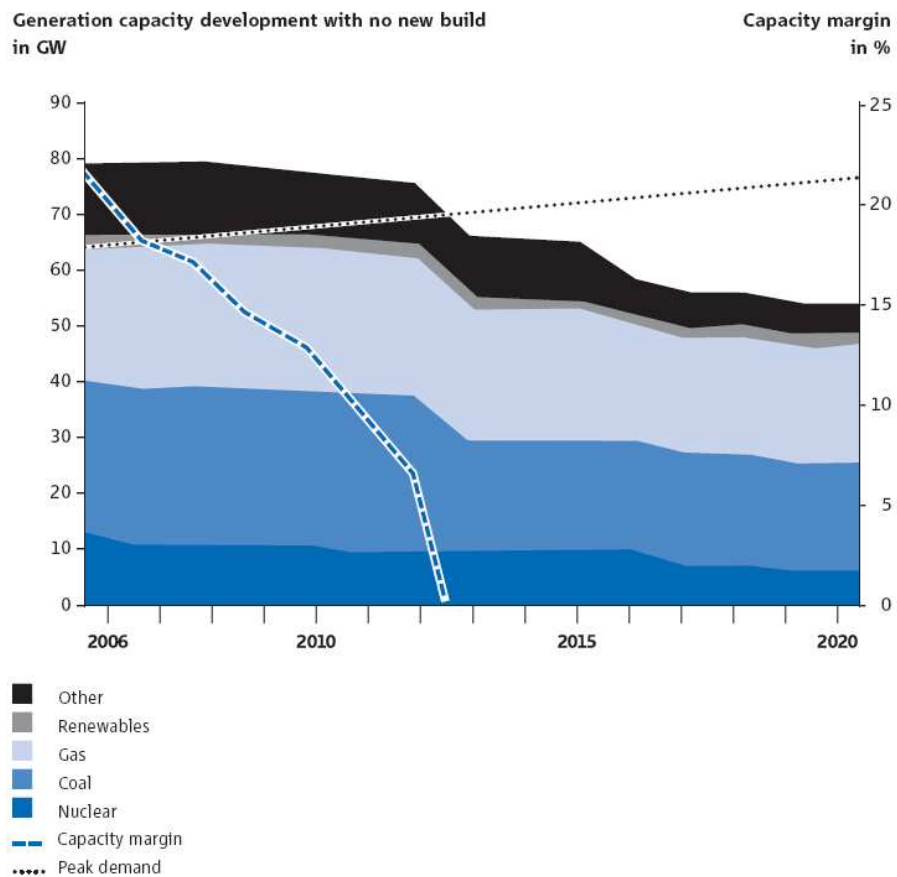

Figure 1.2 - UK electricity generating capacity shut-downs (from RWE 'Facts & Figures 2007', courtesy RWE npower plc:
<http://www2.rwecom.geber.de/factbook/en/servicepages/welcome>).

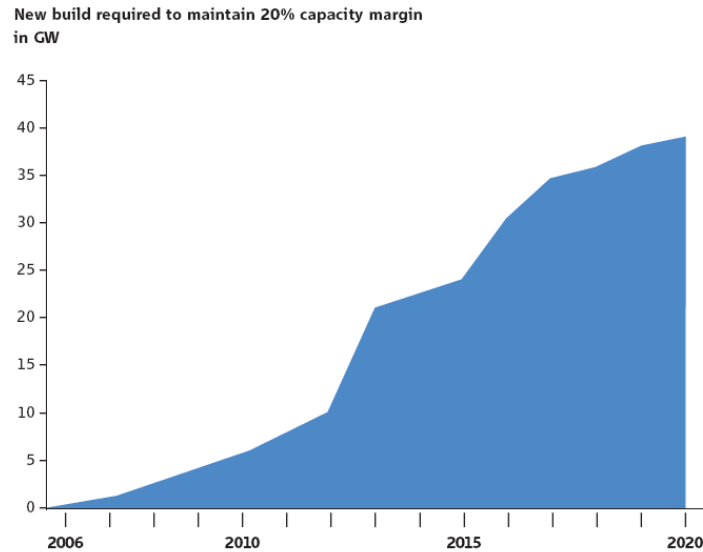

Figure 1.3 - UK electricity generating capacity needed to replace shut-downs and meet rising demand (from RWE 'Facts & Figures 2007', courtesy RWE npower plc: <http://www2.rwecom.geber.de/factbook/en/servicepages/welcome>).

1.2. Future UK Electricity Generation

The Government's energy projections show that the reductions in coal and nuclear power generating capacity, with no new nuclear or coal fired builds, could be replaced by gas-fired stations, along with some generation from renewable sources (see Figure 1.4). In particular, the projections show that the percentage of the UK's electricity supplied by gas-fired power stations could rise from 37% in 2005 (36% in 2006) to approximately 55% by 2020. This would dramatically reduce the diversity of the UK's generation mix and increase dependency on gas for electricity generation, at a time when the UK becomes increasingly reliant on gas imports.

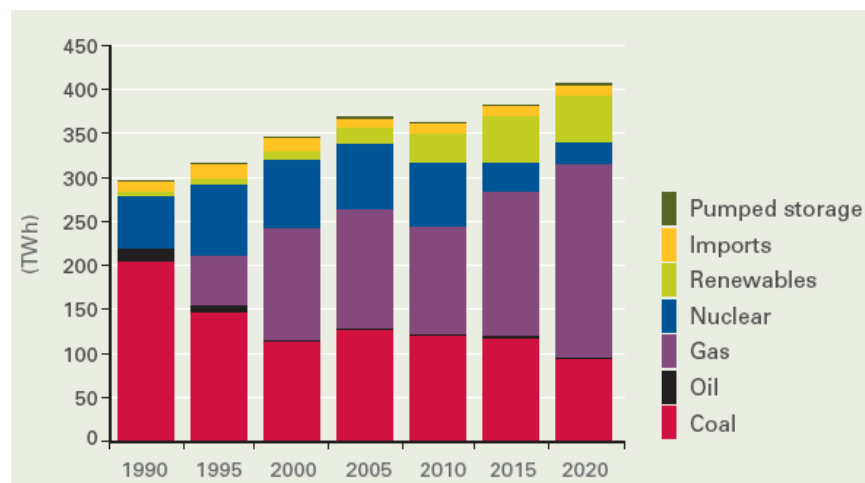

Figure 1.4 - Growth in electricity generation from renewable sources since 1990 (from: the 2006 Energy Review, 'The Energy Challenge', July 2006, BERR).

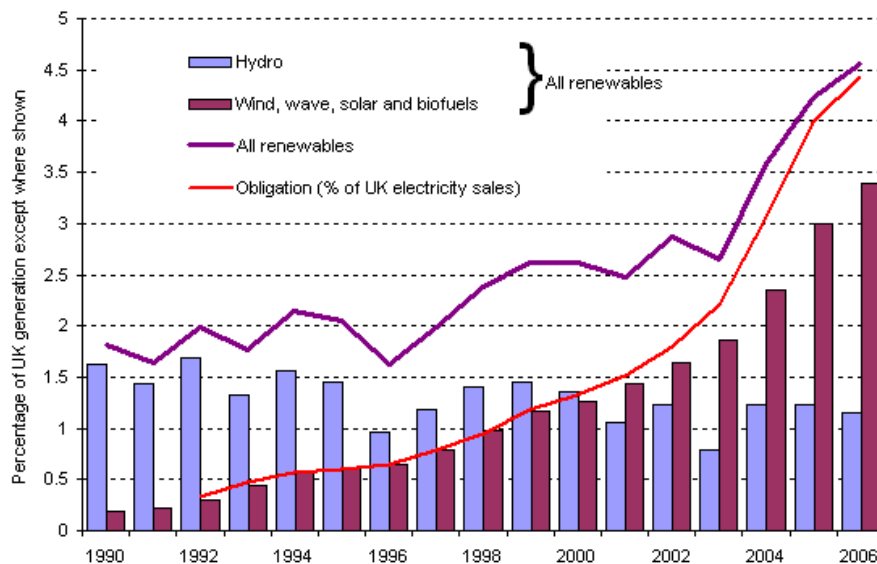

Figure 1.5 - Growth in electricity generation from renewable sources since 1990 (from 'The Digest of United Kingdom Energy Statistics, 2007', BERR).

However, Figure 1.4 also shows the contribution from renewable energy sources growing (also, see later sections of this report) and Figure 1.5 shows how the contribution from renewables has grown to date. Currently, the contribution of renewable energy sources to electricity generation is relatively small (< 5%) and approximately 1% of this is from mature Hydro-Electric Power (HEP) generation in the UK highlands.

With the need to reduce CO₂ emissions, a large number of international and domestic policy mechanisms have been put in place, which dictates how renewable energy sources can contribute to the power needs of the UK. These include the Kyoto Protocol, The Climate Change Levy (CCL), and the Renewables Obligation (RO). These will not be discussed in detail here, other than to mention that the RO is the UK Government's main mechanism for supporting generation of electricity from renewable sources.

The RO is an obligation placed on all licensed electricity suppliers to source a proportion of all electricity supplied from eligible renewable sources, and the proportion of electricity to be supplied via renewables increases each year and for 2006/7 is 6.7%, rising to 15.4% by 2015/16. Since its introduction in 2002, the RO has been successful in stimulating growth in renewable electricity generation, such that it has more than doubled since 2002, and a there is more than 11GW of renewables capacity planned for installation in the UK.

However, despite good progress, there are barriers slowing the rate of renewables deployment in the UK in both the short and long term, which include a scarcity of suitable sites, difficult planning consent procedures and grid connectivity, none of which are described in detail in this report.

1.3. UK Capability in Materials for Power Generation

As will be described in later sections of this report, the UK based materials supply chains for large thermal and nuclear power generation have been eroded quite considerably over the past 10-15 years.

Thus, although the UK power equipment and services sector has a turnover of £30 billion and provides employment for 300,000 people in the UK, it is estimated that since 1990, the UK has lost approximately 70% of the supply chain for components/plant into the power generation sector, which has resulted from the construction of relatively few power stations over the past 10-15 years, as mentioned above.

As the strength of the supply chain has decreased, so the industrial and academic base for research and development in materials for fossil-fired and nuclear power plant has decreased accordingly. However, the UK still possesses a strong knowledge/skills base in fossil fuel and nuclear power plant materials.

In addition, with the decrease in UK based industrial activity in conventional fossil fuel fired and nuclear materials and manufacturing, the need for underpinning R&D in materials applicable to power generation via these technologies has decreased accordingly. At the same time, with the need for reduced CO₂ emissions and electricity generation via renewable energy sources, R&D activity related to materials in renewable energy applications has increased.

However, it should be noted that the balance of funding had perhaps moved away from the 'conventional' technologies and significant programmes and funding have now been put in place to redress this. Thus, increased levels of public body funding have recently been made available for fossil fuel fired and nuclear materials R&D, through the Engineering and Physical Sciences Research Council (EPSRC) and the DTI Technology Programme (now the Technology Strategy Board Collaborative R&D Programme); as will be described in later sections of this report.

It is difficult to quantify how the levels of funding have changed with time for the different power generation technologies, as much of the private sector information is not available. In addition, it is not easy to separate out the materials 'component' of a given public body funded programme. However, some data is available for EPSRC funding over the period 2002/03 to 2006/07, and this is shown below in Figures 1.7 and 1.8, which show the number of projects funded and the value of projects funded respectively. Note: the total number of projects funded over the period 2002/03 to 2006/07, in power generation, transmission, distribution, storage and conservation was 159 and the total funding was £48,971,000.

It should be noted that some individual EPSRC CASE (Cooperative Awards in Science & Engineering) are not included in this analysis.

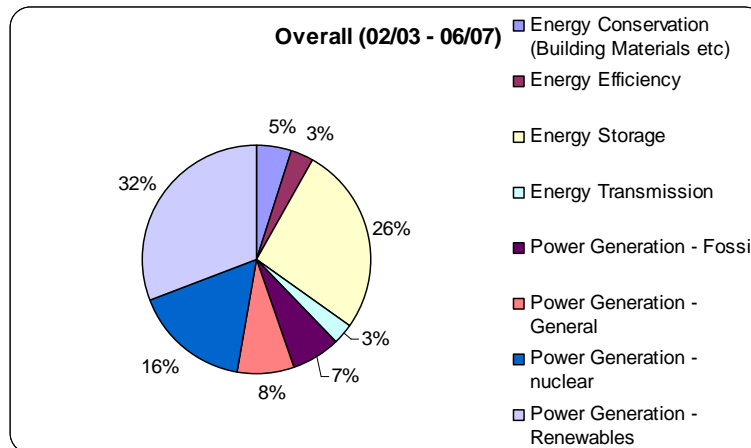

(a)

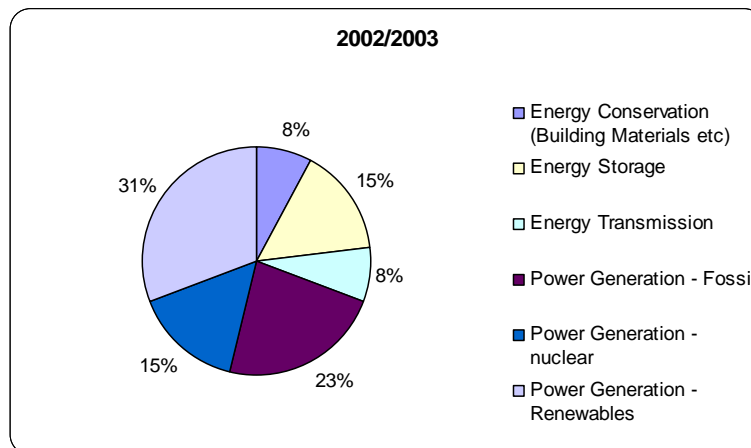

(b)

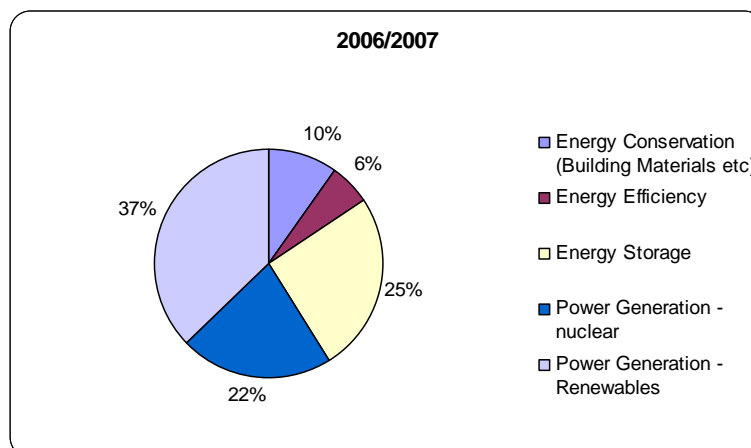

(c)

Figure 1.7 - Analysis of the EPSRC's programme of power / energy projects with a high materials related content – **number of projects** (with thanks to Ms. Vania Croce of EPSRC, Swindon).
(a) Total over the period 2002/03 to 2006/06, (b) 2002/03 and (c) 2006/07.

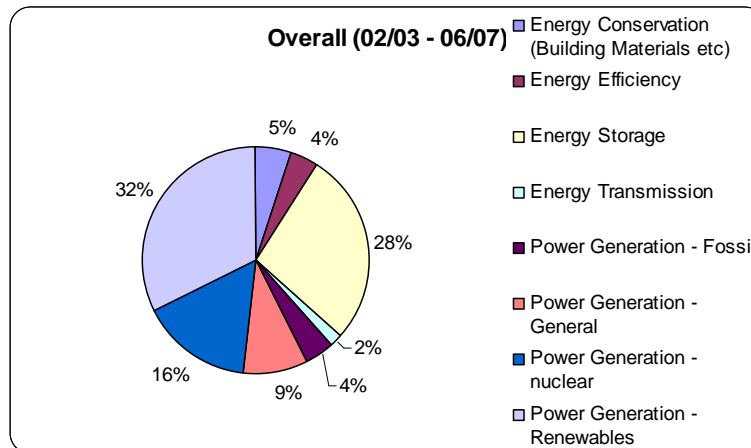

(a)

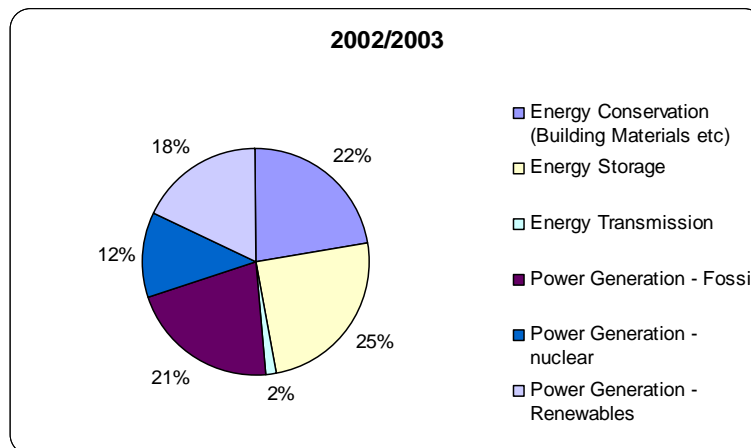

(b)

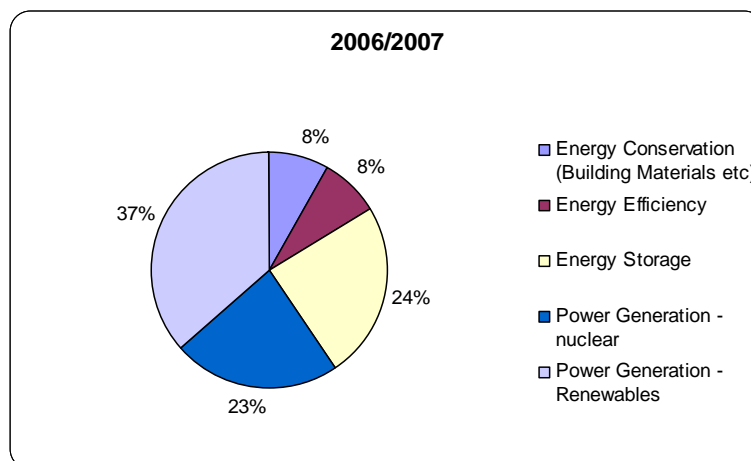

(c)

Figure 1.8 – Analysis of the EPSRC’s programme of power / energy projects with a high materials related content – **value of projects** (with thanks to Ms. Vania Croce of EPSRC, Swindon).

(a) Total over the period 2002/03 to 2006/06, (b) 2002/03 and (c) 2006/07.

The data presented in Figures 1.7 and 1.8 show the following changes in EPSRC funding for power generation related projects, from 2002/03 to 2006/07:

- A dramatic reduction in the funding of projects related to power generation via fossil fuel-fired technologies (to zero in 2006/07).
- A 100% increase in the funding of projects related to renewable energy sources.
- An almost 100% increase in the funding of projects related to nuclear energy.

As will be described in a later section of this report, although the funding of projects related to fossil fuel fired power generation within the EPSRC Programme has decreased to the extent that no funding is now made available for such activities, significant programmes related to fossil fuel-fired generation are supported by the Technology Strategy Board (TSB).

As regards UK capability in materials for power generation, it should be noted also that from discussion with company representatives and academics engaged in activities related to both fossil fuel-fired and nuclear power generation (utilities, OEMs, metals processors / fabricators, coatings companies, universities, etc.) that there is a considerable shortage of skilled scientists and engineers, with a strong background in materials. Thus, most companies and universities have difficulty in recruiting individuals with the required skills, a consequence of the reduced number of students taking materials (and metallurgy, in particular) based degree courses at university.

1.4. Scope of the Report

The report is focused on energy generation by fossil, nuclear and renewable fuels / technology only. Energy transmission, distribution and storage, and energy conservation are not considered. Power, or (strictly speaking) electricity generation via the following technologies are considered:

- Fossil fuel (coal, gas and oil).
- Nuclear (very largely fission)
- Wind
- Marine (wave and tidal)
- Solar Photovoltaics (PV)
- Biomass
- Fuel cells

[Note: Hydro Power (both large and small scale) is not considered, although it should be noted that in 2006, electricity generated from Large Hydro schemes was 1,386 MW.]

Within each of the subsequent sections of this report, the current market opportunity or landscape for electricity generation via the specific 'fuel source' or technology is described and, wherever possible, for each energy type, the main players in the UK's energy materials supply chain will be identified. Thus, the UK's materials & manufacturing supply chain for power generation will be 'mapped'.

In addition, brief descriptions of some of the most significant R&D activities for each specific 'fuel source' or technology are also given.

2. FOSSIL FUEL-FIRED POWER

2.1. The Fossil Fuel-Fired Power Generation Landscape

2.1.1. Introduction

As mentioned previously, in 2006, most of the UK's electricity was generated by gas, coal and nuclear stations. Thirty large (>1GW) power stations meet the majority of electricity demand, which is on average approximately 40GW and approximately 60GW at peak. In 2006, electricity generation from fossil fuel combustion made up more than 75% of the UK's electricity supply (see Figure 1.1 in the Introduction to this report), as follows:

- Gas provided 36% of electricity, a figure which has grown dramatically from 1% in 1990 and is predicted to grow further. In addition to its use in electricity generation, gas is also used to heat approximately 70% of the UK's homes.
- Coal-fired power stations provided 37.5% of electricity, down from approximately two-thirds in 1990.
- Oil-fired power stations provided a little more than 1% of electricity.

In addition to the above, fossil fuels are also used in the generation of heat and power in some Combined Heat and Power (CHP) schemes. As mentioned in the Introduction to this report, CHP is the simultaneous generation of usable heat and power (usually electricity) in a single process, using a variety of fuels and technologies across a wide range of sites and scheme sizes. The basic elements of a CHP plant comprise one or more pieces of major plant such as a reciprocating engine, gas turbine, or steam turbine) driving electrical generators, and the steam or hot water generated in the process is utilised via suitable heat recovery equipment for use either in industrial processes or in community heating and space heating (from the 'Digest of United Kingdom Energy Statistics 2007', BERR, July 2007, which can be downloaded from the BERR website: <http://www.berr.gov.uk/publications/index.html>).

The dramatic increase in Combined Cycle Gas Turbine (CCGT) gas fired power stations between 1990 and 2006, shown in Figure 1.1 (see Section 1), occurred during the second half of the 1990s, known as the 'dash for gas', when the economics of new gas power stations were particularly favourable. However, the new gas fired station builds resulted in an excess of generation capacity and few new power stations have been built since that time.

The contribution from coal and nuclear plants will decrease as power stations close, leaving a power 'gap' of approximately 15GW by 2015. [Note: the closure of the nuclear plants will be described in a later section of this report].

Recently, there has been a rise in electricity prices brought about by higher coal and gas prices. In addition, implementation of initiatives aimed at reducing emissions from fossil-fuel fired power stations, such as the EU Emissions Trading Scheme (ETS) and the Large Combustion Plant Directive (LCPD) (see below) are likely to increase electricity prices still further. Thus, this makes fossil fuel fired plant, and pulverized coal fired plant in particular, quite vulnerable.

However, the International Energy Agency (IEA) World Energy report predicts that world energy demand will increase by 60% between 2000 and 2030, with fossil fuels expected to meet more than 80% of the demand (22% coal, 35% oil and 25% natural gas). Demand for electricity is expected to grow faster than total energy demand, roughly doubling by 2030, with coal expected to remain the largest source of electricity (38%) and natural gas increasing its share (29.5%) to make up for the reduction in oil fired generation.

2.1.2. The Large Combustion Plant Directive (LCPD)

The closure of the coal and few remaining oil fired stations will result from implementation of 'The Large Combustion Plant Directive' (LCPD), which comes into effect in January 2008, and which

imposes two separate constraints on coal and oil fired stations. The first of these is that approximately 11GW of 'opted-out' coal and oil stations close by the end 2015 and the second restricts the operation of around 20GW of coal stations that 'opted-in' to meet the requirements of the LCPD, after 2016.

The LCPD requires operators of the large coal-fired power plants to have fitted equipment to remove sulphur dioxide (SO₂), nitrogen oxides (NO_x) and dust from their emissions, or to operate for a limited number of hours (20,000 hours) over the 2008-2016 timeframe. The LCPD does not limit CO₂ emissions. As regards the second constraint, operators may choose to invest in the 'opted-in' power stations between now and 2016 to comply with reduced emission limits and so extend their operating life.

Of the 22.5GW of existing power stations which may close by 2020 (BERR Energy White Paper 2007), 8.5GW of coal-fired capacity (of a total of 28GW) will close by the end of 2015 to meet the requirements of the EU LCPD, as will approximately 2.5GW of oil fired power stations – see Table 2.1 below.

Installation	Operator	Fuel	Installed capacity (MW _e)	Number of boilers	Number of plant	Capacity opted in ¹⁾ (MW)	Capacity opted out ²⁾ (MW)	FGD ³⁾ status
Drax	Drax Power	Coal	3,960	6	1	3,960	0	Fitted
Eggborough	British Energy	Coal	2,000	4	1	2,000	0	2 units fitted
Cottam	EDF Energy	Coal	2,000	4	1	2,000	0	Fitted
Ferrybridge	Scottish & Southern Energy	Coal	2,000	4	2	1,000	1,000	Under construction
Fiddlers Ferry	Scottish & Southern Energy	Coal	2,000	4	1	2,000	0	Under construction
Didcot A	RWE npower	Coal	2,000	4	1	0	2,000	No FGD
Tilbury	RWE npower	Coal	1,020	4	2	0	1,020	No FGD
Kingsnorth	E.ON UK	Coal	2,000	4	1	0	2,000	No FGD
Ratcliffe	E.ON UK	Coal	2,000	4	1	2,000	0	Fitted
Ironbridge	E.ON UK	Coal	1,000	2	1	0	1,000	No FGD
Rugeley	International Power	Coal	1,000	2	1	1,000	0	Contracting
West Burton	EDF Energy	Coal	2,000	4	2	2,000	0	Fitted
Peterhead	Scottish & Southern Energy	CCGT	1,320	2	1	1,320	0	N/A
Longannet	Scottish Power	Coal	2,304	4	1	2,304	0	Contractor selected
Cockenzie	Scottish Power	Coal	1,152	4	2	0	1,152	No FGD
Aberthaw	RWE npower	Coal	1,500	3	1	1,500	0	Under construction
Kilroot	AES	Coal/Oil	520	2	1	520	0	Under construction
Uskmouth	Uskmouth Power	Coal	393	3	1	393	0	Fitted
Littlebrook	RWE npower	Oil	1,370	3	1	0	1,370	No FGD
Fawley	RWE npower	Oil	1,000	2	1	0	1,000	No FGD
Grain	E.ON UK	Oil	1,300	2	1	0	1,300	No FGD
Total			33,839	71	25	21,997	12,972	

1) Compliant with emission limits in LCPD.

2) Limitation of operating hours to 20,000 between 01/01/2008 and 12/31/2015. No requirement to fit FGD.

3) FGD: Flue gas desulphurisation.

Table 2.1 - Large Combustion Plant Directive (LCPD) shut-down of 13 GW by 2015 (or earlier) in the UK (from RWE 'Facts & Figures 2007', courtesy RWE npower plc: <http://www2.rwecom.geber.de/factbook/en/servicepages/welcome>).

Thus, over the next two decades, the UK will need substantial investment in new generation capacity to replace the closing coal, oil and nuclear power stations, and to meet expected increases in electricity demand. The energy or power 'gap' is expected to be largely filled in the short-term (the next five years) by new gas fired power stations and wind power generation (see later Section of this report), although other renewables (eg, biomass), some CHP, clean coal technologies (eg, coal gasification) and waste incineration will also contribute (see Figure 2.1).

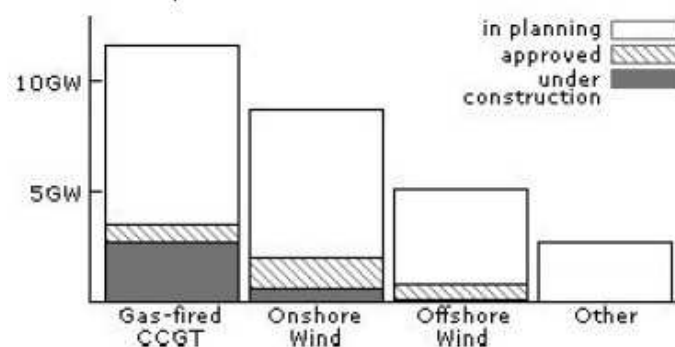

Figure 2.1 - Short-term proposed new electricity generation (from The Parliamentary Office of Science and Technology 'Postnote', February 2007, Number 280).

2.1.3. The New 'Dash for Gas'

As mentioned above, combined Cycle Gas Turbine (CCGT) technology has been the dominant technology in terms of new power station builds over the last ten years or so. However, rising gas prices have led to higher electricity prices and the EU Emissions Trading Scheme (ETS), and the cost of carbon emissions, will further increase the operating cost of gas generation. Growing gas imports and issues such as limited gas storage capacity and relatively few pipeline links to the continent will also affect the cost-effectiveness of gas-fired power generation.

The relatively high efficiency of CCGT power generation and the urgent need to install new generating capacity has led to the announcement of the construction of a number of CCGT power stations, which are currently undergoing construction or have been announced for construction by the utilities. Examples are given below, which total approximately 8 GW of capacity.

- E.ON UK plc: a £350M, 1,220MW station at Drakelow in South Derbyshire has received planning permission.
- Severn Power Ltd. (a wholly owned subsidiary of Carron Energy): a £400M, 800MW station will be built near Newport, S. Wales on the site of the former Uskmouth A (coal fired) power station. Siemens has been selected as the preferred bidder for engineering, procurement & construction, operation & maintenance and a long-term service agreement.
- RWE npower plc: a £600M, 1,650MW station will be built at Staythorpe near Newark (Notts.), with four generating units, each of approximately 400 MW capacity. Alstom has been appointed as the main contractor, and the first unit will be operational in 2010.
- RWE npower plc: a £800M, 2,000MW station will be built at Pembroke, Wales. Alstom has been appointed as the main contractor, with commissioning expected in 2011.
- Centrica plc - £400M, 885MW station at Langage, Devon, which is due to start during winter 2008/09. Alstom has been awarded the engineering, procurement and construction contract, and long-term maintenance contract.
- Scottish & Southern Energy plc, with Ireland's ESB International: a 400M, 840MW development known as Marchwood Power Ltd., Southampton, which will be in commercial operation in winter 2009/10. A turnkey contract has been awarded to Siemens.
- Bridestones Developments Ltd.: a 380MW station at Carrington, Trafford, Manchester.

2.1.4. Carbon Abatement (or 'Cleaner Coal') Technologies

As mentioned above, coal is expected to remain the largest source of fuel for electricity generation, within the UK and globally. This is linked to its abundance and, therefore, to security of supply. However, it is clear that conventional pulverised fuel combustion technologies cannot be used if efficiencies are to be increased and significant reductions in CO₂ emissions are to be realised.

Thus, there are three principal methods for reducing carbon emissions from fossil fuel fired power generation, as follows:

- Improved coal-fired power station efficiency, through the use of super-critical steam cycles (advanced boilers, improved turbines and gasifiers, etc.) through which efficiencies can be increased by 10% or more and emissions can be reduced by 20%. These technologies can also be used to retrofit existing power stations.
- Co-firing coal with biomass (which will be described in a later section of this report), in which coal-fired power stations can combine their fuel with biomass and to decrease emissions by about 10%.
- Carbon capture and storage or sequestration (CCS), which involves capturing the carbon dioxide emitted when burning fossil fuels, transporting it and storing it in secure spaces such as geological formations, including old oil and gas fields and aquifers (natural underground reservoirs) under the seabed. Carbon dioxide capture technologies are based on three generic approaches: pre-combustion, post-combustion and oxyfuel and can be applied to coal or gas-fired power generation.

Although a number of UK based companies are active in gasification (eg, Integrated Gasification Combined Cycle, IGCC) developments (eg, Doosan Babcock Energy Ltd.) and CCS technologies (eg, Jacobs Consultancy Ltd., RWE npower plc and E.ON UK plc), because these technologies are still under development, UK based materials supply chains simply do not exist at present, and their description is considered to be beyond the scope of this report. However, descriptions of the CCS technologies and UK capability are given in: 'Capability Brochure: Carbon Dioxide Capture and Storage', CB015, March 2005, DTI/Pub URN 05/901, which can be downloaded from the BERR website, <http://www.berr.gov.uk/publications/index.html>.

The design specification for the UK's first Carbon Capture & Storage (CCS) plant was significantly refined in early October 2007, when it was announced that the Government will support a single post-combustion coal-fired project.

On a related note, in October 2007, RWE npower plc announced plans to design and build the first CO₂ capture pilot plant at its Aberthaw coal-fired power station in S. Wales. An initial £8.4M investment will focus on a 1MW capture plant, with further investment planned to support a capture and storage demonstrator plant of at least 25MW. Both plants will be designed using post-combustion technology, which can be applied to existing coal-fired power plants.

In addition to the development of stand-alone CCS power generation plants, although not economically viable at present, it is important to have the option of retrofitting CO₂ capture equipment to future power generation builds.

2.2. Summary of Fossil Fuel Fired Technology and Plant

Detailed descriptions of the operation of the major equipment of fossil fuel fired power generation plant are beyond the scope of this report, and in this section, only brief descriptions of components and plant are given for:

- Pulverised fuel boilers and steam generators
- Steam turbines
- Gas turbines

2.2.1. Pulverised Fuel Boilers and Steam Generators

A review of the UK's capability in pulverized fuel boilers was published by the Department of Trade & Industry (DTI) in March 2001 (see: 'UK Capability: Pulverised Coal-Fired Power Station Boilers', CB010, March 2001, DTI/Pub URN 01/593, which can be downloaded from the BERR website, <http://www.berr.gov.uk/publications/index.html>). In addition, a capability brochure on Heat Recovery Steam Generators (HRSGs), used in CCGT plant for example, was also published in March 2004 (see: Capability Brochure: 'Heat Recovery Steam Generators', CB014, March 2004, DTI/Pub URN 04/716, which can also be downloaded from the BERR website. HRSGs are used in CCGT plant

A detailed description of the operation of pulverized fuel boilers and HRSGs is beyond the scope of this report. However, it is necessary that some of the major components of a boiler are described, and the description of a pulverized fuel operation given in the DTI Capability document is summarized below.

A schematic diagram of a pulverized fuel boiler and ancillary plant is shown below in Figure 2.2 below.

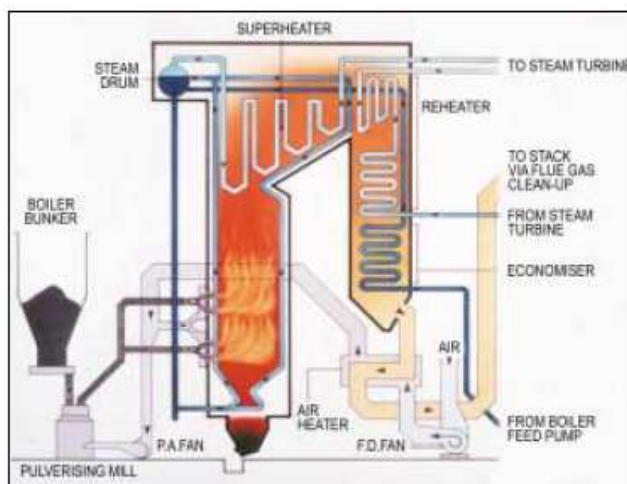

Figure 2.2 - Schematic of a pulverised fuel boiler (from: 'UK Capability: Pulverised Coal-Fired Power Station Boilers', DTI Capability Brochure CB010, March 2001 (DTI/Pub URN 01/593)).

In a typical pulverized fuel system, coal is fed to a pulverising mill and the resulting pulverized fuel is conveyed pneumatically to the boiler combustors. The basic steam cycle for power generation entails pumping water into a boiler to which heat is supplied to convert the water into steam. The steam is expanded through a steam turbine, which drives an electric generator and the exhaust steam from the turbine is then condensed and pumped back to the boiler to complete the cycle.

Modern boilers are designed to maximise heat transfer from the combustion system to the steam system with minimum loss of heat via the boiler flue gases. The main heat-exchange systems in the boiler are the furnace wall tubing, the superheaters and reheaters, etc. (see Figure 2.3).



Figure 2.3 - A water wall panel (Courtesy of Alstom).

2.2.2. Steam Turbines

A review of the UK's capability in steam turbines was published by the Department of Trade & Industry (DTI) in March 2000 (see: 'UK Capability: Steam Turbines', CB009, March 2000, DTI/Pub URN 00/653, which can be downloaded from the BERR website, <http://www.berr.gov.uk/publications/index.html>). A detailed description of the operation of a steam turbine is beyond the scope of this report. However, it is necessary that some of the major components of a steam turbine are described, and the description of steam turbine operation given in the DTI Capability document is summarized below.

Steam turbine power stations vary from relatively low power output to unit sizes of up to approximately 1200MW for fossil steam turbines and up to 1800MW for nuclear steam turbines (see Figure 2.4).



Figure 2.4 – A large (1560 MW) HP/IP turbine (Courtesy of Alstom Power Ltd.).

Steam is supplied at high pressure and temperature to the steam turbine and the energy of the steam is converted into mechanical energy by expansion through a series of 'fixed blades', or 'nozzles' (also called vanes and diaphragms), and the rotating blades. A row of fixed blades together with its associated moving blades is termed a 'turbine stage'. The fixed blades are attached to the 'turbine casing', which contains the steam pressure, and the moving blades are attached to the turbine rotor (see Figure 2.5).

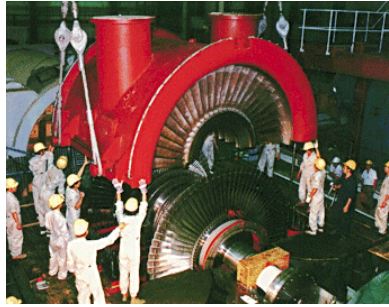

Figure 2.5 – A turbine casing being lowered into position, showing rotor blades fixed blades (nozzles, vanes or diaphragms).

Materials developments and associated fabrication technologies have led to continuous rise in operating pressures and temperatures of steam turbines, which has resulted in a substantial increase in the thermal efficiency of power generation to approximately 47-49% in the latest plant using super-critical steam conditions of approximately 600-620°C and 300 bar.

The high temperatures and high pressures create major challenges in materials development for rotors, casings, valve chests, blading and bolting, and development of new ferritic steels, has enabled an increase in steam temperature to around 620°C. When new materials are developed, in order to demonstrate that the required properties are met, prototype components must be manufactured and tested to destruction.

2.2.3. Gas Turbines

In principle, land based (industrial) gas turbines are very similar to, but typically larger than an aero engine gas turbines, and the actual turbine drives a generator.

Industrial gas turbines used in 'simple cycle' or CCGT power plants extract energy from a flow of hot gas produced by combustion of gas or fuel oil in a stream of compressed air. An upstream compressor is mechanically coupled to a downstream turbine and a combustion chamber in between. The compressed air is mixed with fuel and ignited in the combustor. The hot gases are then directed over the turbine's blades, which makes the turbine rotate and mechanically power the compressor.

A schematic diagram showing the materials of construction of a gas turbine are shown in Figure 2.6 below. The compressor blades and discs are typically made of steel or titanium alloys, whilst the combustor and turbine components (blades and discs) use Ni-base superalloys. Cobalt based alloys are also used in combustor applications.

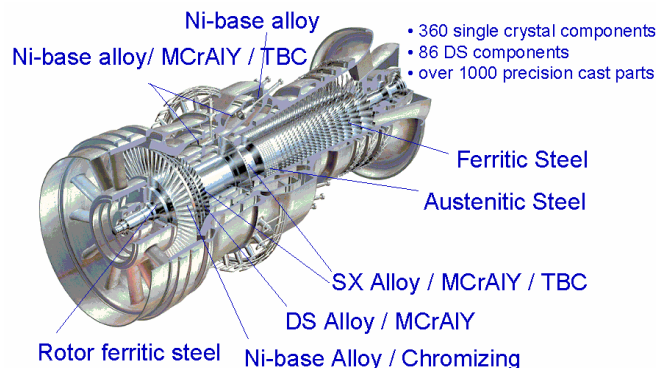

Figure 2.6 – Schematic of a gas turbine engine annotated with some of the materials of construction. (Courtesy of Alstom Power Ltd.).

Simple-cycle gas turbines convert fuel energy into electricity and heat, which is normally lost to the atmosphere. However, the waste heat can be used to create steam to power a separate (steam) turbine and this is the principle of the CCGT power plant.

As a result of their flexibility, it is estimated that at least half of all new global power generating capacity (small and large scale) added to 2010 is likely to use gas turbines.

2.3. UK Supply Chain for Boilers & Steam Generators

There is only one major (and global) UK based player in the design and manufacture of pulverized fuel boilers and steam generation equipment for fossil and nuclear power, although there are a number of other UK based suppliers of plant and components for steam generation, as will be described below.

2.3.1. Doosan Babcock Energy Ltd. (Renfrew, Scotland)

With group headquarters in Crawley, Surrey and European Headquarters in Renfrew, Scotland, Doosan Babcock Energy Ltd. (<http://www.doosanbabcock.com/>) is a wholly owned subsidiary of Doosan Heavy Industries and Construction Ltd. (Korea).

Doosan Babcock is a specialist energy services company operating in the thermal power, nuclear, petrochemical, oil and gas and pharmaceutical industries. The company is also a leading international steam generation OEM and is one of only four companies worldwide to have proprietary boiler technology (the others are Alstom (France), Babcock & Wilcox (USA) and Foster Wheeler (USA)).

Doosan Babcock has considerable experience in the design and engineering of systems such as pipework, pressure parts and boiler support structures, for a range of OEM boilers, Heat Recovery Steam Generators (HRSGs) and nuclear applications. The company's activities also include the inspection, repair, maintenance, plant upgrade and life extension services, and assurance service, for thermal power steam generators.

Doosan Babcock is one of the world's leading suppliers of supercritical power plant technology, and through its licensing agreement with the Harbin Boiler Company (China), has secured the largest percentage of new build thermal power stations in China.

Doosan Babcock's supercritical boiler designs require the purchase of between 4,000 and 4,500 tonnes of pipe and tube, which is currently sourced as follows:

Pipe

Doosan Babcock purchases conventionally formed carbon and alloy steel pipe to ASME or its equivalent standards. However, equivalent forged hollow machined material is sourced from forgemasters where necessary.

The major suppliers of steel grades such as P12 (1Cr-0.5Mo), P22 (2.25Cr-1Mo), P91 (9Cr-1Mo-0.25V), P92 (9Cr-2W-0.5Mo-0.25V) in pipe form are Vallourec & Mannesmann (France and Germany), Tenaris (Italy and Romania), Productos Tubulares SA (Spain), Bentler GmbH (Germany).

For the same forged steel grades, suppliers are Forge Fedriga SpA, Forgiatura Morandini SpA, IBF and Ofar Forgiatura SpA (all Italian). In addition, material is sourced from UK based distributors of companies which include Buhlmann Group GmbH (Germany), RTR Handelsgesellschaft GmbH (Germany) and Federal Steel Supply Inc. (USA).

Tubing

Major suppliers of carbon and alloy tubing (eg, the 1Cr T11 grade, the 2.25Cr-1Mo T22, T23 and T24 grades, and the 9Cr, P91 and P92 grades) are Vallourec & Mannesmann Mills, Teanris, Bentler and Bao Steel (China). As in the case of pipe, carbon and alloy tubing is also sourced from distributors.

Major suppliers of stainless steel tubing (304H, 316H and 347H) are Tubacex Tubos Inoxidables (Spain), Sandvik (Sweden) and Mannesmann DMV Stainless (Germany & USA). Additional stainless steel grades are supplied by DMV and Sumitomo (Japan).

Plate

Stainless Steel Plate (eg, 310, 304L 316L) is sourced from Outokumpu Stainless (rolled in Sweden), and is also sourced from stockists.

Forged Bar

Forged bar material such as F11 (1.25Cr-0.5Mo) and F22 (2.25Cr-1Mo) are mainly sourced from stockists and the Corus 'Durehete' grades for bolting applications are sourced from Corus Engineering Steels (Rotherham)

Other (Strip, Castings, Structural Steel, Welding Consumables)

Doosan Babcock sources other materials as follows:

- Membrane panel strip to suit the base tube material is sourced from Ferrostaal GmbH (Germany) and forged pipe fittings in carbon and alloy steel grades (9Cr, F91 and F92) as for the high pressure systems are supplied by stockists such as Dylan België (Belgium).
- Precision Castings for the tube attachments are sourced in grades to suit the tube material from local casting companies: Cronite Castings Ltd. (Crewkerne, Somerset) and Incamet Ltd. (Douglas, Lanarkshire, Scotland).
- Large castings for the pulverised fuel mill spares (eg, for rings and balls, yokes, spindle shafts and wear plates) are supplied by companies such as Bradken Ltd. (Scunthorpe), Somers Forge Ltd. (Halesowen, Birmingham) and Larson & Toubro Ltd. (India).
- Structural steel sections and plate are supplied by Corus.
- Doosan Babcock manufactures approximately 80% of the welding consumables it uses in the form of MMA/TIG wire (Babcock Welding Products), with the major welding consumable companies such as Oerlikon, ESAB, Metrode and Bohler Thyssen supplying the remaining 20%.

From the above, it is readily apparent that very little pipe and tubing is sourced within the UK. Unfortunately, there is currently no UK based supplier of seamless stainless steel tubing and the UK's only (current) supplier of high alloy steels and Nickel based alloy pipe (Wyman-Gordon Ltd., Livingston) exports almost all of its products. Various tubes, fittings, etc. may also be sourced by the utilities directly from stockholders (eg, Aalco Ltd. (national) and RTR Ltd. (Newcastle)).

2.3.2. Additional UK Based Boiler and Steam Generation Capability

Unit Superheater Engineering Ltd. (Swansea) manufacture tubular products for the petrochemical, power generating, nuclear and other major industries. The company can provide a complete package for boiler tube replacement, up to full boiler tube wall replacement, and is able to supply a complete range of distribution components (headers and manifolds). The Group also has extensive bending, machining, heat treatment and NDT capabilities.

TEI Greens Overseas Ltd. (Wakefield, W. Yorks) is one of the largest independent fabricators of Heat Recovery Steam Generator (HRSG) components in Europe, although fabrication now takes place at factories in China. The same applies to its wide range of boilers and superheaters. However, the company is perhaps best known for its boiler economisers and 70% of the UK's coal-fired power

stations use its economisers. Greens also manufactures a wide range of extended heating surface tubes, including helical finned tubes, for boilers, economisers, gas coolers and heat exchangers.

TEI Ltd. (Wakefield, W. Yorks) provides service in the manufacture, installation and repair & maintenance of high pressure steam generation plant and equipment.

Thermal Energy Construction UK Ltd. (Castle Donington, Derbs.) also offer maintenance and repair services (eg, heat exchanger and boiler re-tubing) for HRSGs and large coal fired boilers.

2.4. UK Supply Chain for Steam Turbines

As mentioned previously, there have been significant changes in the ownership of the major power plant OEMs, as mainland European parent companies have acquired indigenous manufacturers. Thus, many of the major suppliers of key materials and components are now based elsewhere in Europe.

This is particularly true of large steam turbine manufacture, although Alstom maintains capability in the supply of retrofit equipment from Alstom Power Ltd. (Rugby) and Siemens provides spares, repairs and service from Siemens Power Generation Ltd. (Newcastle). Siemens' Newcastle facility provides major spares for all ex-Parsons turbines (UK and overseas) and the Siemens fleet, and acts as 'overflow' for Siemens' German facilities for the manufacture of some steam turbine 'modules'.

For new build steam turbines, Alstom Rugby manufactures High Pressure(HP), Intermediate Pressure (IP) and Low Pressure (LP) turbines and 'tunes' the turbine(s) (eg, number of stages) to meet both boiler output and generator capacity. In the recent past, Alstom Rugby has manufactured combined HP/IP and single HP turbines of up to 540MW and 800MW capacity respectively, and retains this capability.

Thus, of the world's four largest manufacturers of steam turbines (Alstom, Siemens, GE and Mitsubishi Heavy Industries), two maintain significant capability in the UK.

In addition, a number of other UK based companies are active in providing spares, repairs and retrofit services for steam turbines, and in the original manufacture of relatively small steam turbines, as will be described below.

Also, a significant number of UK based companies have the capability to supply high integrity components (castings, forgings, etc.) into steam turbine applications, but are either not doing so currently or, if doing so, are largely exporting their products.

However, at the time of publication of the DTI's 'UK Capability: Steam Turbines' document in early 2001, the following companies were listed as being engaged in the development and supply of materials for steam turbines and associated components: Corus Group (Corus plc), Firth Rixson Superalloys (now Firth Rixson Forgings Ltd.), Allvac-SMP (now ATI Allvac Ltd.), Howmet (now Alcoa Howmet Ltd.), Ross and Catherall (part of Doncasters plc), Wiggin Alloys Products and Special Metals Wiggins (now Special Metals Wiggin Ltd.), Goodwin Steel Castings, Ltd., Sheffield Forgemasters Ltd., William Cook Hi Integrity Ltd. (now William Cook Cast Products Ltd.). Most are still active in steam turbine component manufacture.

In addition to the large steam turbine OEMs (Alstom and Siemens), Peter Brotherhood Ltd. (Peterborough) specialises in the design and manufacture of steam turbines, with power outputs from 1MW to 40MW, suitable for a range of applications, including waste incineration CHP schemes.

Also, a number of additional companies offer services in the provision of spares, repair, overhaul, upgrade and retrofit of steam turbines, and these include:

- Weir Services, a division of Weir Group PLC (Barton-on-Humber and Bedford).
- Wood Group Heavy Industrial Turbines (Cumbernauld and Dundee, Scotland, and Worcester).

2.4.1. Steam Turbine Components

In this section, the capabilities of UK based companies, with respect to steam turbine component manufacture are described.

Rotors

With the buoyancy of the large forgings market, for power generation and other sectors, supply of large rotor forgings is limited and all OEMs tend to use the same suppliers.

Approaches to rotor construction differ, with Alstom using forged and welded constructions, in which individual forged parts are welded together, whereas companies such as Siemens use single forgings.

Within the UK, large rotor forgings (say 30-50 tonnes) can only be supplied by Sheffield Forgemasters (Sheffield), and rotor forging are also supplied by European forgemasters in Germany (eg, Saarschmiede GmbH and Buderus GmbH) and Italy (eg, ThyssenKrupp Acciai Speciali Terni). Very large rotor forgings are also supplied by Japan Steel Works (JSW).

Turbine Casings

The inner turbine casings are cast steel, the alloy content of which depends on service conditions (temperature and pressure), with compositions typically ranging from 1CrMo to 9CrMoV. The service conditions, of temperatures in excess of 500°C and pressures up to 350 bar, require high integrity castings. In general, there is a worldwide shortage of capacity for the largest castings and these are generally sourced overseas from casters in Germany, Poland and Mexico.

However, William Cook Cast Products Ltd. (Sheffield) and Goodwin Steel Castings Ltd. (Stoke-on-Trent, Staffs.) are able to supply some intermediate size castings for turbine casings, and some casings may also be fabricated from forged steel components.

Goodwin Steel Castings can supply single piece castings to 10,000kg; fabricated components to 18,000kg and fabricated assemblies to 50,000kg. Supply can be fully machined and assembled.

Blading & Diaphragms

Forged bar stock or 'envelope' forgings for blading and diaphragms (stators or vanes) can be sourced within the UK from Firth Rixson Special Alloys Enpar Ltd., (Sheffield), from Corus Engineering Steels (CES) bar stock, or from bar stock from other UK and mainland European suppliers. In addition, forgemasters in Germany (eg, Saarschmiede GmbH and Buderus GmbH), Austria (eg, Böhler Edelstahl GmbH) and Italy (eg, from CBlade SpA) also supply into the UK.

The forged bar and 'envelope' forgings are then machined to final form at the steam turbine manufacturers facilities (eg, Alstom Rugby or Siemens Newcastle), or at independent machinists.

In addition, Alcoa Howmet Ltd. (Exeter) and AETC Ltd. (Leeds) can supply precision Ni based alloy castings for machined turbine blades.

Miscellaneous Castings

Low alloy steel steam chest castings (eg, 1Cr0.5Mo, 0.5Cr0.5Mo0.25V and 2.25Cr1Mo castings) can be sourced in the UK from companies such as William Cook Cast Products Ltd. (Sheffield) and Goodwin Steel Castings Ltd. (Stoke-on-Trent, Staffs.). However, steam chest castings are also sourced in mainland Europe (eg, from Poland).

Various large valve castings, such as main stop valve and control valve castings, in 9-13Cr alloys, can be sourced in the UK from Goodwin Steel Castings Ltd. (Stoke-on-Trent, Staffs.) – see Figure 2.7 below. Fully machined and assembled main stop and control valves in low alloy CrMo & CrMoV and 9.5%Cr, and all internals, can be supplied by Goodwin Steel Castings Ltd., Stoke-on-Trent.



Figure 2.7 - Main stop valve body for a super-critical application, produced from two 10Cr-MoVWNbN, P911 castings, weld fabricated to make a 16,000kg valve body.
(Courtesy Goodwin Steel Castings Ltd.).

Cast iron components, such as low pressure castings and bearing pedestals are sourced from within the UK and mainland Europe, from suppliers which include Coupe Foundry Ltd. (Preston, Lancs.), Fonderie Sabiem (Italy) and Buderus Edelstahl GmbH (Germany).

Cast white metal bearings are supplied by companies such as J.H. Richards Ltd. (Birmingham), K.C. Engineering Ltd. (Consett, Co. Durham) and Osbourne Engineering Ltd. (Cramlington, Northumberland), but these are also sourced in mainland Europe.

In addition, low alloy steel 'oil work' castings can be supplied by companies such as Weirs Materials & Foundries Ltd. (Manchester) and Bonds Foundry Co Ltd. (Bishop Auckland, Co. Durham).

Miscellaneous Forgings

Suppliers of low alloy steel steam chest valve components include Somers Forge Ltd. (Halesowen) and Formet Ltd. (Newcastle).

Miscellaneous high strength forgings are sourced in mainland Europe from Italy and France, and some precision Cobalt ('stellite') alloy castings for blade leading edge and valve seats are supplied by Doncasters plc. (Sheffield).

Corus supply a range of 'Durehete' grade steel bar stock for bolting, via Firth Rixson Enpar Special Alloys (Sheffield). Firth Rixson also supply some forged Nimonic 80A bar for bolting, and Aubert & Duval (France) also supply bar for bolting applications.

In addition, forged internals (valve and pipe components) are also sourced in mainland Europe from companies such as Saarschmiede GmbH (Germany) and Böhler Edelstahl GmbH (Austria).

Other Components

Miscellaneous materials / components are sourced as follows:

- Steam turbine pipework is supplied by companies which include Doosan Babcock Ltd. (Renfrew) and Vallourec & Mannesmann Tubes (France & Germany).
- Steam turbine shims and fixtures have their own major supply chains, typically involving SMEs (Tier 2 & 3 suppliers).
- Springs may be sourced within the UK from suppliers which include Hanson Springs Ltd. (Rochdale) and Cross Manufacturing Company Ltd. (Bath & Devizes).
- Various rings and seals are sourced in the UK; for example, from Cross Manufacturing Co Ltd. (Bath and Devizes, Somerset).

Nickel Alloy Castings

For higher temperature applications (700-720°C) Nickel alloys such as Alloy 625 (NiCrMoNb) are used. Goodwin Steel Castings Ltd. (Stoke-on-Trent) was the main casting manufacturer participants in

the EU Thermie AD700 programme (described below). The company also supplied the COMTES 700 turbine valve in Alloy 625 and the test valve for the Japanese '700 programme'.

Coatings

Currently, very few coatings are used in steam turbines, although ongoing development work associated with super-critical and ultra super-critical (USC) steam cycles will see the move to widespread coating application in steam turbines. In this respect, the UK is served very well by a number of world leading coatings companies, as will be described below in Section 2.6.

2.4.2. Summary of UK Based Steam Turbine Capability

Although not an exhaustive list, UK based companies with capabilities in major steam turbine materials/components, some of whom are mentioned above, are as follows:

- Rotors: Sheffield Forgemasters Ltd. (Sheffield)
- Turbine casings: William Cook Cast Products Ltd. (Sheffield), Goodwin Steel Castings Ltd. (Stoke-on-Trent, Staffs.).
- Forged turbine discs: Firth Rixson Forgings Ltd. (Darley Dale, Matlock, Derbs.)
- Forged bar for turbine blades, diaphragms and/or bolting: Firth Rixson Enpar Special Alloys Ltd. (Sheffield) and Independent Forgings and Alloys Ltd. (IFA Ltd., Sheffield).
- Steam chest casings and valve components: Somers Forge Ltd. (Halesowen, Birmingham).
- Alloy steel forging and machining stock (bar) for blades and bolting: Corus Engineering Steels (Rotherham).
- Steel castings for steam chests and valves: Goodwin Steel Castings Ltd. (Stoke-on-Trent), and William Cook Cast Products Ltd. (Sheffield). Goodwin can also cast large Ni alloy castings.
- Coatings, surface treatment and abradable seals: the major gas turbine coatings and seals companies, which include Chromalloy UK Ltd. (Alfreton, Derbs.), Sermatech Ltd. (Lincoln), Praxair Surface Technologies Ltd. (Swindon), Sulzer Metco (Stalybridge and Stockport) and Monitor Coatings Ltd. (South Shields, Co. Durham) and Metal Improvement Co Ltd. (Newbury, Berks).
- Examples of other components:
 - Rotor wedge bars: Osborn Metals Ltd. (Bradford, W. Yorks).
 - Steam turbine pipework: Doosan Babcock Energy Ltd. (Renfrew)
 - Low pressure castings: Coupe Foundry Ltd (Preston, Lancs.),
 - Various rings and seals: Cross Manufacturing Co Ltd. (Bath and Devizes, Somerset).

Clearly, for future super-critical and ultra-super critical (USC) steam turbine applications, companies currently supplying to the aero or industrial gas turbine markets will also have the capability to supply materials / components for steam turbine applications. These companies include precision Ni base alloy casters of blades and diaphragms (eg, AETC Ltd (Leeds), Alcoa Howmet Ltd. (Exeter) and Doncasters plc (Droitwich, Worcs. and Chard, Somerset)).

Also, Special Metals Wiggin Ltd. (Hereford) currently supplies Ni base alloy bar for forging and Wyman-Gordon (Lincoln and Livingston) forge Ni base alloy turbine blades; both companies would be capable of supplying materials / components for super- and USC steam turbine applications.

2.5. UK Supply Chain for Gas Turbines

Rolls-Royce plc is a world leading supplier of power systems and services for civil aerospace, defence aerospace, marine and energy applications. The group has manufacturing and service facilities in 50 countries, with main UK sites in Derby, Bristol, Hucknall (Notts.), Inchinnan (Glasgow), Sunderland and Barnoldswick (Lancs.).

In general, suppliers for Rolls-Royce's land based power systems are global companies and are primarily embedded within the company's aero engine supply chain. The current supplier base numbers approximately 750 companies, and sourcing in emerging low-cost markets has increased from 9% to 11% of Rolls-Royce purchases.

Engineering support for Rolls-Royce's Energy business aftermarket is based in Ansty (W. Midlands), Mt Vernon (OH, USA) and Montreal (Canada). Service facilities in Montreal, Houston and Brazil, complemented by a joint venture with the Wood Group plc in Aberdeen and San Leandro (CA, USA), provide engine, package and accessory repair and overhaul services. Overall, the Energy Business shares a substantial part of its worldwide authorised repair vendor network with the rest of the Rolls-Royce group.

For land based gas turbines, Rolls-Royce's major design/assembly sites are in Canada (Montreal), the US (Mount Vernon, OH & Indianapolis, IN) and in the UK at Ansty (W. Midlands) and Bootle (Liverpool), although it has recently been announced that the latter is to close. The Energy business, which includes the manufacture of Industrial Gas Turbines (IGTs), makes up only approximately 7% of Rolls-Royce's business, based on 2006 turnover, with civil aerospace accounting for approximately 53% of turnover, followed by defence aerospace (22%) and marine (18%). In general, the group has a common supply chain; for example, high pressure turbine blades are manufactured at a number of common facilities for the aero, marine and industrial markets; ie, they utilise the same or similar components.

Rolls-Royce's major products for the energy sector are gas turbine packages for power generation and oil & gas power projects. Prime products are a range of 501, RB211 and Trent aero-derivatives, which can be used in simple cycle, simple cycle cogeneration, combined cycle and combined cycle cogeneration plants (4-58 MW generating sets and up to 150 MW, 2 x Trent combined cycle), in addition to a large, supported legacy Avon fleet in the same role.

Although not discussed in any detail within this report, Rolls-Royce's gas engine packages, for industrial power stations & municipal applications, include the Bergen K and Bergen B Diesel engine packages (2.2-8.5 MW).

Within the UK, Siemens' manufacture small gas turbines (approx. 5-15 MW range at the Lincoln site (Siemens Industrial Turbomachinery Ltd.); the same site also supports service (repair, retrofits, etc.) for gas turbines.

In addition, Siemens Power Generation Ltd. (Newcastle) also supports Siemens' German facilities and Siemens Lincoln in the servicing of gas turbines, although all large gas turbine components are sourced from Siemens in Berlin.

A number of other UK based companies are also active in providing spares, repairs and retrofit services for gas turbines, and these include:

- Weir Services, a division of Weir Group plc (Barton-on-Humber and Bedford).
- Wood Group Heavy Industrial Turbines (Cumbernauld and Dundee, Scotland, and Worcester).
- Rolls Wood Group (Aberdeen, Scotland), a joint venture established in 1990, between Rolls-Royce and Wood Group plc to maintain, repair and provide field service to gas turbine operators.

Also, a number of UK based companies have the capability to supply high integrity components (castings, forgings, etc.) into gas turbine applications, but are either not doing so currently or, if doing so, are largely exporting their products.

As will be described below, because of global sourcing, many of the major suppliers of key materials and components for gas turbines are now based overseas, either within mainland Europe or in the US.

2.5.1. Gas Turbine OEM and Component Manufacture

In this section, the capabilities of UK based companies, with respect to gas turbine, and gas turbine component, manufacture are described. It should be noted that the construction of the turbine varies, such that Rolls Royce do not manufacture using a rotor, but instead 'assemble' compressor and turbine discs. This is not the case for the relatively small gas turbines manufactured at Siemens

Lincoln, where a steel rotor is used. Thus, throughout the following, some reference is made to differences in the materials of construction and, therefore, the suppliers of some components.

Raw Materials

In the case of Rolls-Royce, suppliers of raw materials for gas turbine manufacture include TIMET (Ti) and VSMPO (Ti, Russia), although these materials are purchased via forgers, such as Ladish Co, Inc. (USA), Wyman Gordon, Doncasters plc and Firth-Rixson. In addition, Ni, Fe, Ti and Al alloys are purchased from the supply chain as stock materials for in-house manufacture of finished component/sub assemblies from suppliers. Global suppliers of Ni based alloys include Norilsk (Russia), Allegheny Ludlum Inc. (USA), including ATI Allvac Ltd. (Sheffield), and Precision Cast parts Corp. (PCC Special Metals, USA and Special Metals Wiggin Ltd., Hereford).

Compressor Materials

Rolls Royce compressor discs are typically forged and machined from creep resisting martensitic steel (coated), Ti-6-4 and Ti-6246, and the Ni based alloys IN718 and 'Waspaloy', depending on product and compressor temperature. The disc forgers include Ladish (USA), Wyman-Gordon, Doncasters plc and Firth Rixson, and most forgings are finished in the UK by Rolls-Royce.

In the case of Siemens Lincoln, rotor and stator blades at the 'colder' end of the compressor are 17-4PH (17Cr-4Ni) steel, sourced from Corus Engineering Steels and stockholders, such as Gould Alloys Ltd (Chesterfield, Derbs.) and Firth Rixson Special Alloys Enpar Ltd. (Sheffield), in the form of bar stock, which is then machined in-house at Siemens. In addition, some stainless steels are also used at the higher temperature, 'back-end' of the compressor, which are again sourced from stockists.

Rotor discs at the 'colder' end of the compressor are typically low alloys steels such as 1.5Ni-Cr EN24 and the 2.5Ni-Cr alloys, EN25 & EN26, also supplied by Firth-Rixson.

Rotor blades at the 'hotter end' of the compressor are 12Cr based steels (eg, FV448 and FV535), supplied by Firth Rixson Ltd., which is machined in-house at Siemens. Böhler Edelstahl also supplies a further 12Cr alloy, X19.

Combustor Materials

Combustor materials are typically made from weldable Ni base sheet alloys, of between 1-3mm in thickness, such as Haynes 230 and Nimonic 75. Materials are supplied by companies such as Haynes International Inc. (USA), Special Metals Wiggin Ltd. (Hereford), and stockists, and for Rolls-Royce, little fabrication takes place in the UK.

For Siemens gas turbines, burners are typically fabricated from 310 stainless steel bar, which is machined in-house.

Combustor components are frequently 'protected' with a Thermal Barrier Coating (TBC), which will be discussed in more detail below (see Section 2.6.).

Turbine Blades

Rolls-Royce use Ni base alloys such as CSMX-4, Directionally Solidified (DS) Mar-M-002 and a range of conventionally cast Nickel based alloys, dependant on the turbine stage and blade temperature.

Similarly, Siemens Lincoln uses CMSX-4 single crystal Ni alloy castings, supplied by the Precision Cast parts Corp. (PCC Special Metals) in the USA, or Directionally Solidified (DS) Ni-base alloys, such as IN6203, also supplied by PCC Special Metals.

At the 'colder end' of Siemens' turbines, Ni base castings of alloys such as MAR-M247, IN939 and IN738 are used. The specific alloy used is dependant upon the engine operating cycle and the size of the part. In addition, one of the Low Pressure (LP) blades is manufactured from forged Udimet720, from either Symmetry Medical (ex-Thorntons Precision Components Ltd., Sheffield) or Doncasters plc.

As in the case of combustor materials, most turbine blades are coated to improve component life with an aluminide based system.

Turbine Discs

Turbine discs are forged aero-derivative materials such as Udimet720, together with 'Waspalloy' and IN718, and steel discs are also utilised in in-service legacy products.

Forging companies source ingot from Siemens approved suppliers, which could be in the UK, the US, or within Europe. 'Hot end' discs are forged from IN718 from Wyman-Gordon Ltd. (Livingston, Scotland).

Turbine Rotor Shafts

Turbine rotor shafts are manufactured from either martensitic steel or nickel based alloys.

Bolted Joints

Materials for bolted joints are sourced relatively widely (Tier 2/3 suppliers), as these are not specialist gas turbine materials / components; for example, from PRD Fasteners Ltd., (Willenhall, W. Midlands), and are made from materials which include 321 and 316L stainless steel grades.

Stator

In Siemens gas turbines, the stator is either cast as a single piece or in multi-vane segments of IN939, of which there are a number of potential suppliers, including PCC (Special Metals, USA) and Alcoa Howmet Ltd. (Exeter).

Turbine Casings

For Rolls-Royce gas turbines, these are ring-rolled products, similar to combustor materials, supplied by companies such as Doncasters plc, Firth Rixson (Sheffield and US sites) and Aubert & Duval (France).

For Siemens Lincoln, the casings and combustor housings are cast iron, cast at companies such as Ductile Castings Ltd. (Scunthorpe) and William Cook Cast Products Ltd. (Sheffield).

Coatings & Seals

Rolls-Royce has a joint venture with Chromalloy UK, Ltd., Turbine Surface Technologies, Ltd. (TSTL), based in Annesley (Notts.), which carries out Air Plasma Spray (APS), Low Pressure Plasma Spray (LPPS), Pt plating, Electron Beam Plasma Vapour Deposition (EBPVD) coating of turbine components.

For Rolls-Royce, compressor seal materials are applied in the form of coatings, sourced from companies such as Sulzer Metco Ltd. (Gwent) and HC Starck Ltd. (Sheffield). Turbine seals are typically nickel based alloy honeycomb structures.

Siemens sources coatings, which include Aluminides, MCrAlY's and Thermal Barrier Coatings (TBCs) from Sermatech Ltd. (Lincoln) and Sulzer Metco Coatings UK Ltd. (Stalybridge, Lancs.). In addition, Siemens sources abrasible seal materials from companies such as Sermatech Ltd. (Lincoln) and Sulzer Metco Neomet Ltd. (Stockport), and include Nimonic 86 and Haynes 214 'honeycombs' for the High Pressure (HP) turbine rotor blades.

2.5.2. Summary of UK Based Gas Turbine Capability

Although not an exhaustive list, UK based companies with capabilities in major gas turbine materials/components, some of whom are mentioned above as suppliers to Rolls-Royce and Siemens, are as follows:

- Raw materials:
 - Titanium: TIMET UK Ltd. (Birmingham & Swansea).
 - Nickel: Special Metals Wiggin Ltd. (Hereford), ATI Allvac Ltd. (Sheffield).
 - Steel: Corus plc.
- Compressor materials: Wyman Gordon Ltd. (Lincoln), Doncasters plc, Firth Rixson Special Alloys Enpar Ltd. (Sheffield) and Firth Rixson Forgings (Sheffield).
- Shafts: Steel and Nickel alloys: Firth Rixson (Meadowhall).

- Combustor materials: Special Metals Wiggin Ltd. (Hereford).
- Forged turbine blades: Wyman Gordon Ltd. (Livingston, Scotland), Doncasters plc
- Precision cast turbine blades: Alcoa Howmet (Exeter) and AETC Ltd. (Leeds).
- Stator components: Alcoa Howmet Ltd. (Exeter).
- Turbine casings: William Cook Cast Products Ltd. (Sheffield).
- Coatings and seals: Chromalloy UK Ltd. (Alfreton, Derbs. and Eastwood, Notts.), Turbine Surface Technologies Ltd. (Annesley, Notts.), Praxair Surface Technologies Ltd. (Swindon), Sermatech Ltd. (Lincoln and Ripley, Notts.), Sulzer Metco UK Ltd. (Stalybridge, Lancs. and Neomet Ltd., Stockport), Monitor Coatings Ltd. (South Shields, Co. Durham), Plasma & Thermal Coatings Ltd. (Newport), Diffusion Alloys Ltd. (Hatfield, Herts) and Metal Improvement Company Ltd. (Newbury, Berks.).

2.5.3. Overseas Gas Turbine Manufacturers

Gas turbines from overseas suppliers such as General Electric (USA), Ansaldo (Italy), Turbomach (Switzerland) and Mitsubishi Heavy Industries (Japan) have been supplied into the UK for CCGT applications, as have gas turbines from Alstom and Siemens facilities within mainland Europe. For the UK's new generation CCGT power stations, most will be supplied as turnkey plant from Alstom and Siemens in mainland Europe.

2.6. Coatings

With the drive to higher gas turbine inlet temperatures for increased efficiency and reduced emissions, there is an increasing demand to develop materials and coatings which are capable of operating at elevated temperatures. In addition, the gas turbine OEMs are looking for new sealing materials (between blades and casings) to seal gas paths, again for increased efficiency.

From a commercial perspective, the OEMs are also seeking to increase operating times between major services and so the requirement for the combined substrate and coatings system is for increased time of operation at higher temperatures, whilst maintaining structural integrity.

A detailed description of the various coating technologies and the coatings themselves is beyond the scope of this report. However, many texts are available, which describe the coatings themselves, their function and the various coating processes.

The UK has a number of world class coatings companies, brief details of some of which are given below, and companies with a presence in the UK also supply powders for coatings applications (eg, Sulzer Metco, Praxair and HC Starck Ltd. (Sheffield)).

Chromalloy United Kingdom Ltd. and Turbine Surface Technologies Ltd. (TSTL)

Chromalloy United Kingdom Ltd. (Chromalloy) and Turbine Surface Technologies Ltd (TSTL) are considered together as the latter is a 50:50 Joint Venture (JV) between Chromalloy UK Ltd. and Rolls Royce plc. Chromalloy operates three facilities in the East Midlands area for the coating and repair of gas turbines, both aero and industrial (IGT), at Alfreton, Derbs. (coating), Eastwood, Notts. (repair and overhaul) and at Annesley, Notts. The latter is the JV with Rolls-Royce, which employs approximately 200 people. A further 200 people are also employed across Chromalloy's Alfreton and Eastwood sites.

In addition to more conventional high temperature coating (eg, LPPS and HVOF), currently within the UK, TSTL and Chromalloy are the only companies which offer EBPVD coating; which was originally specified by Rolls-Royce. Within the UK, Rolls-Royce use TSTL exclusively for coating all of its gas turbine blades and components. Chromalloy UK Ltd. has a global customer base of both aero gas turbine and IGT OEMs, and airline companies.

Both Chromalloy and TSTL apply the patented Pt 'Low Cost Bond Coat' and Chromalloy also apply a wide range of aluminide and MCrAlY bond coats.

Praxair Surface Technologies Ltd. (PSTL)

Praxair Surface Technologies Ltd. is a wholly owned subsidiary of Praxair Inc. (USA). PSTL operates out of units located in Swindon, Southam (Warks.) and Weston-super-Mare where a total of 220 people are employed.

The core business of PSTL is the application of wear resistant, corrosion resistant and thermal barrier coatings to parts mainly for the Aerospace (Airframe and Engines), Industrial Gas Turbines, Oil, Primary Metals and Print industries. Out of the Swindon and Southam facilities PSTL applies these coatings by thermal spray processes such as Plasma Spray, HVOF (High Velocity Oxy-Fuel) D-Gun® or Super D-Gun®. In addition, the Weston super Mare facility provides a proprietary Electroplating Co-deposition process to produce its Tribomet® range of coatings.

As mentioned above, Praxair also supplies thermal spray powders and equipment with which to apply these powders.

Sermatech Ltd.

Sermatech has facilities in Lincoln and Ripley (Notts.), with approximately 180 employees across both sites. The Lincoln and Ripley sites support the Industrial Gas Turbine and Aerospace markets respectively.

Sermatech applies a range of compressor and turbine blade coatings including MCrAlY and Pt-Aluminide bond coats and ceramic Thermal Barrier Coatings (TBCs), applied using HVOF and thermal spraying techniques.

Sulzer Metco

Sulzer Metco UK is part of the Sulzer Metco Group, and employs approximately 100 people at coatings Services facility in Stalybridge, Lancs. (Sulzer Metco Coatings UK Ltd.), Turbine Component facility in Stockport, Cheshire (Neomet Ltd.), and a Sales and Service site in S. Wales.

Sulzer Metco's Neomet Ltd. facility in Marple, Stockport specialises in the manufacture of metallic honeycomb structures (see Figure 2.8). The primary use for these products is as abradable gas path seals in both Aero and Industrial Gas Turbines. Neomet is also able to offer a wide range of fully dense amorphous metal braze foils and performs.

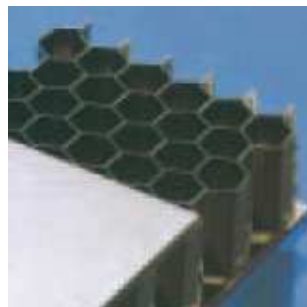

Figure 2.8 - Honeycomb seal for gas turbine engine (Courtesy of Sulzer Metco Turbine Components: Neomet Ltd.).

Sulzer Metco UK specialises in the supply and service of thermal spray equipment and materials.

Monitor Coatings Ltd.

Monitor Coatings Ltd's (South Shields, Co. Durham) core business is thermal spray and slurry coatings for the Aerospace market (40% of business), using 'traditional' Flame Spray, Low Pressure Plasma Spray (LPSS), and High Velocity Oxy-Fuel (HVOF) techniques, and a patented ceramic slurry application.

2.7. UK R&D Activity in Fossil-Fuel Energy Materials

In this section, publicly funded R&D projects in fossil fuel fired power generation are mentioned, as are some of the activities ongoing within companies active within the sector. Clearly, this list is not exhaustive.

2.7.1. EPSRC SUPERGEN 'Conventional Power Plant Lifetime Extension (PLE) Consortium'

As part of the EPSRC's SUPERGEN project, there is a 'Conventional Power Plant Lifetime Extension (PLE) Consortium' (see: www.supergenple.net), which has received approximately £2.1M of funding and has four university and eleven industrial partners, and consists of five main technical work packages, together with a networking activity. The Consortium partners are:

- University: Universities of Bristol, Cranfield, Loughborough and Nottingham.
- Industrial: Alstom Power Ltd., Chromalloy UK Ltd., Alcoa Howmet Ltd., E.ON UK plc, Doosan Babcock Energy Ltd., NPL, QinetiQ, Rolls Royce plc, RWE npower plc, Sermatech International UK Ltd., Siemens Industrial Turbomachinery Ltd.

The main research themes of the PLE Consortium are:

- Condition monitoring.
- Environmental degradation and protection.
- Microstructural degradation.
- Modelling of mechanical behaviour.
- Life assessment toolbox.

2.7.2. Technology Strategy Board (TSB) Collaborative R&D Programme

In 2005, the DTI (now BERR) launched a Strategy for Developing Carbon Abatement Technologies for Fossil Use and following publication of the 2006 Energy Review, the Government announced that £35M would be available for Carbon Abatement Technologies (CAT). This Programme now forms part of the Technology Strategy Board's (TSB) Collaborative R&D Programme.

Details of Technology Strategy Board Collaborative R&D Programme projects can be found at the searchable <http://technologyprogramme.org.uk/site/publicRpts/default.cfm?subcat=publicRpt1>) and the largest projects relevant to fossil fuel fired power generation are summarized below.

- 'Advanced Materials for Low Emission Power Plant' is a major project contributing to UK-USA collaboration in energy R&D, with the aim to provide:
 - Materials with improved high temperature properties (corrosion, oxidation, mechanical).
 - Improved coating systems.
 - Enhanced lifetime prediction methods.
 - Improved inspection and condition monitoring techniques.

The project runs from April 2004 until March 2008, with a total cost of approx. £6.7M, with approx. £2.3M from the BERR and the remainder from the project partners: Alstom Power Ltd., Corus plc., E.ON UK plc, Doosan Babcock Energy Ltd., NPL, RWE npower plc, Siemens Industrial Turbomachinery Ltd. and the University of Liverpool.

- 'Future Coal Fired Power Plant': 'Alloy Developments for Critical Components' project is aimed at:
 - Developing materials with increased creep strength and resistance to steam oxidation.
 - Increased understanding of microstructural evolution in advanced materials and weldments, steam oxidation and coating degradation mechanisms.
 - Mechanical behaviour of advanced materials on lab samples and full size prototypes.
 - Demonstration of prototype manufacturing, joining, NDE and coating capabilities for large components.

The project runs from September 2004 until July 2008, with a total cost of approx. £1.95M, with approx. £780k from the Technology Strategy Board and the remainder from the project partners: Corus UK, E.ON UK plc, Doosan Babcock Energy Ltd., NPL, Metrode Products Ltd. TWI, Cranfield University and Loughborough University.

- 'Modelling Fireside Corrosion of Heat Exchanger Materials in Advanced Energy Systems' is aimed at developing predictive models for corrosion processes in high temperature boiler components. The project runs from January 2007 until January 2010, with a total project cost of £1.76M, with £896K from the Technology Strategy Board. The project partners are: E.ON UK plc, (lead), RWE npower plc, Doosan Babcock Energy Ltd., Cranfield University and the National Physical Laboratory (NPL).
- 'Improved Modelling of Material Properties for Higher Efficiency Power Plant' runs from January 2007 until January 2010, with a total project cost of £2.24M, with £1.25M from the Technology Strategy Board. The project partners are: E.ON UK plc, Doosan Babcock Energy Ltd, one steam and gas turbine manufacturer, two research organisations and two universities.
- 'Materials for Arduous Cycle and Emissions (MACE)' is aimed at developing new materials technologies (a compressor abradable, a sulphidation resistant Ni disc material and a novel single crystal turbine blade technology) to reduce gas turbine fuel consumption. The project runs from April 2005 until April 2008, with a total project cost of approximately £3.71M, with £1.79M from the Technology Strategy Board. The project partners are: Rolls-Royce plc, Praxair Surface Technologies Ltd, Sermatech Ltd, Universities of Birmingham, Cambridge, Cranfield and Swansea.
- 'Nanostructured Thermal Barrier Coatings' is aimed at developing Electrophoretic Deposition (EPD) for the coating of re-entrant components. The project runs from June 2006 until October 2009, with a total project cost of approximately £1.15M, with £575k from the Technology Strategy Board. The project partners are: PowdermatriX Faraday Partnership (lead), Rolls-Royce plc, Sulzer Metco (UK) Ltd, MEL Chemicals, Ionotec Ltd., Teer Coatings Ltd., Tetronics Ltd. and Manchester University.
- 'High Temperature Sealing for Advanced Super Critical Steam Turbine Plant' is aimed at extending the capabilities of valve and turbine sealing systems. The project runs from June 2006 until October 2009, with a total project cost of approximately £611k, with £305k from the TSB. The project partners are: Alstom Power Ltd. (lead), E.ON UK plc, Cross Manufacturing Company Ltd. and NPL.
- 'Advanced Materials for Low Pressure (LP) Steam Turbines' is aimed at developing advanced materials and improved processes for increased generating efficiency. The project runs from July 2006 until July 2009, with a total project cost of approximately £1.25M, with £626k from the Technology Strategy Board. The project partners include: Alstom Power Ltd. (lead), Corus plc, E.ON UK plc, Sheffield Forgemasters Ltd. and NPL.
- 'Industrial and Utility Scale IGSC (integrated Gasification Single Cycle) Coal Power Stations with CO₂ Capture Integrated Gasification Single Site' is aimed at producing costed designs for new and retrofit coal based power stations incorporating near 100% carbon capture. The project runs from July 2006 until July 2009, with a total project cost of approximately £1.21M, with approximately £559k from the Technology Strategy Board. The project partners are: Jacobs Consultancy UK Ltd, CO₂ -Global AS, Siemens plc Power Generation, MAN Ltd and Imperial College, London.

2.7.3. EU Funded R&D Activities

Large, multi-partner European Community collaborative programmes are running currently in which UK based companies are playing active roles. For example:

- The COST 536 project: 'Alloy development for Critical Components of Environmental Friendly Power Plant (ACCEPT). The overall aim of the project is to develop new (ferritic) high temperature steels with improved creep and oxidation properties, which will allow increases in steam parameters of thermal power plants to above 300 bar/600°C. UK based companies involved in the project are Alstom, Doosan Babcock and Corus.
- The COST 538 project 'Plant Lifetime Extension', aimed at life extension in boilers and gas turbines. Alstom Power Ltd., Cranfield University, Nottingham University, NPL, E.ON UK plc, RWE npower plc, British Energy plc.
- The third phase of the AD700 project (COMTES 700), 'Advanced (700°C) Pulverised Fuel-fired (PF) Power Plant' is targeting steam boiler and turbine operating conditions of 700°C and 400 bar. In this project, Nickel based alloys are being developed for performance assessment under these severe steam conditions. Alstom Power Ltd. is a partner in this project and other UK based companies were involved in phases one and two of this large programme.

2.7.4. Selected UK Based Company & RTO R&D Activities

In this section, some of the activities of UK based companies in fossil fuel fired power generation activities are listed. It is not meant to be exhaustive, but reflects some of the input given by individual companies, and Research and Technology Organisations (RTOs), and also refers to participation in publicly funded activities such as the Technology Strategy Board Collaborative R&D Programme (see above).

2.7.4.1. Equipment / Plant OEMs

Alstom Power Ltd. (Rugby)

Alstom regards R&D as a priority in the continuous improvement of the performance, functionality and cost-effectiveness of products and services, through developing new technical solutions or innovative application of existing elements such as:

- Emerging new materials, where gaining understanding of their application to products is a critical factor in improving performance and cost-effectiveness.
- Advanced engineering simulation systems, which enable rapid design and development timescales.

These improve the lifetime of mechanical components in steam turbines, and the power outputs of electrical machines, all of which translate into lower costs. In addition, R&D into the reduction of the environmental impact of products is a priority. Specific examples include:

- Reducing atmospheric emissions through improved power generation efficiencies, novel combustion systems which inhibit NO_x formation in gas turbines, new boiler schemes for clean coal combustion, and even genuinely zero-emission systems which capture all the CO₂ from fuel
- Finding ways to minimize the noise generated by the operation of the plant by understanding how it is generated so it can be efficiently inhibited
- Embedding environmental impact analysis into the design process, so that products can be designed for minimal whole life environmental cost. The Research and Development efforts are driven essentially by current and future market needs.

Within the UK the R&D focus is primarily on steam turbine retrofit and associated technologies (Rugby), Boiler retrofit (Derby) and Power service (Ashby). The main materials R&D focus is on steam turbine and boiler materials, materials characterisation and materials database development.

Alstom takes part in a number of publicly funded collaborative R&D programmes, such as:

- Technology Strategy Board Collaborative R&D Programmes on seals and materials modeling.
- 'Cleaner Coal' technology programmes on advanced alloys for 700°C steam conditions, collaboration with the US on coatings, materials degradation and standardization.

Rolls-Royce plc (Various Locations)

Current R&D priorities include the development of tailored systems solutions to the challenges of delivering lower emissions, increased efficiency, increased reliability, repairability and reduced cost of ownership.

The focus is on incremental improvements in existing systems (5-10 year horizon), whilst looking for the innovative step change, disruptive technology for the future (10-20 year horizon). The particular focus over the next few years will be oxidation/corrosion understanding, control and repair technology and launching appropriate 10-20 year step change programmes.

Current R&D spend is approx. 10% of Rolls-Royce turnover, at £747M gross R&D in 2006, with private venture costs of £370M (Rolls-Royce Annual Report 2006). The R&D expenditure on energy related activities cannot be separated out, as much of the technology is aero-derived.

Much of the outsourced university work is through the approximately thirty University Technology Centres (UTC's, http://www.rolls-royce.com/education/utc/uk/default_flash.jsp) and includes significant materials related activities at The University of Birmingham (Ti base alloys), Cambridge University (Ni base alloys), Swansea University (Ti base alloys), Universities of Cranfield & Strathclyde (Performance Engineering), Nottingham University (Manufacturing Technology) and the University of Sheffield (Materials Damping).

Siemens Industrial Turbomachinery Ltd. (Lincoln)

Much of Siemens R&D is 'cross-bordered' - ie, carried out within the Siemens Power Generation Group of companies. Current R&D expenditure at Siemens Lincoln is approximately £4M per annum, of which £330k per annum is for Materials Technologies. Current R&D priorities include combustion emissions and fuel flexibility, turbomachinery aerodynamics, heat transfer, high temperature materials and coatings systems, and controls.

Siemens Lincoln participates in UK Government (eg, Technology Strategy Board Collaborative R&D Programme) and EU-funded projects (eg, associated with life extension of existing plant). Developments are focused on improved high temperature materials and coatings, which are able to tolerate corrosive containments, and ongoing UK based R&D activities include activities at:

- The University of Birmingham (Profs. Roger Reed & Paul Bowen) on microstructural modelling and materials performance.
- Loughborough University (Prof. Rachel Thomson) on microstructural characterisation.
- Leicester University (Prof Helen Atkinson, Prof Andrew Strang) on microstructure analysis of material degradation.

Doosan Babcock Energy Ltd. (Renfrew)

In 2007, Doosan Babcock launched a new standalone R&D facility at its Renfrew site, which is to conduct research into leading edge boiler technology. The facility currently employs approximately 40 people, with a target of rising to 250 by 2015, with an annual budget of approximately £10M.

In 2006, Doosan Babcock's unfunded research programmes amounted to approximately £2.8M and funded research programme expenditure was approximately £1.3M. Activities at the company's Technology & Engineering facility in Renfrew include:

- Carbon Dioxide Capture & Storage (CCS).
- Advanced Materials Development.
- Waste & Renewables.
- Advanced Welding Technologies.
- Nuclear Decommissioning.
- Asset Integrity Management.

- Non-Destructive Testing.
- Advanced Component Testing.

Doosan Babcock employs approximately 350 UK based specialists/engineers and has both a burner test rig and a combustion test facility, which are both available to undertake tests for other organisations.

Doosan Babcock are currently involved in a number of collaborative European projects (eg, COST 536, Thermie AD 700), together with Technology Strategy Board funded projects, working with partners which include E.ON UK plc, Alstom Power Ltd., Corus plc, Leicester University, Loughborough University, Cranfield University, NPL and QinetiQ.

2.7.4.2. Power Generating Companies (Utilities)

RWE npower plc (Swindon)

RWE's current R&D priority is that of Clean Coal/Carbon Capture. The company's current R&D spend is approximately €74M, with approximately £1.5M spent in the UK by RWE npower. The company participates in Technology Strategy Board supported projects at a number of UK based universities: Loughborough University, Bristol, Swansea, Cranfield, Nottingham, Southampton, Imperial College and test houses such as Bodycote, and Incotest.

RWE npower participates in the following Technology Strategy Board Collaborative R&D Programme projects (see above):

- 'Modelling Fireside Corrosion of Heat Exchanger Materials in Advanced Energy Systems'.
- 'Advanced Materials for Low Emission Power Plant'.

In addition, RWE npower participates in the EPSRC's SUPERGEN I & II 'Conventional Power Plant Lifetime Extension (PLE) Consortium'.

E.ON UK plc (Ratcliffe-on-Soar)

E.ON UK's current R&D priority is that of low carbon power generation and in the materials field, the structural integrity of current and new plant materials. The company's R&D spend is approximately £8M per annum total in the UK, with approximately £1M per annum related to materials and structural integrity.

E.ON UK plc partners a number of universities, including Birmingham, Bristol, Cranfield, Imperial College, Loughborough and Nottingham, some of which are through collaboration in publicly funded programmes. In addition, E.ON UK plc supports activities at Research and Technology Organisations (RTOs), such as TWI and NPL.

E.ON UK plc participates in a number of publicly funded projects, including the following:

- 'Modelling Fireside Corrosion of Heat Exchanger Materials in Advanced Energy Systems', in which E.ON is programme leader and contributes £450k.
- 'Improved Modelling of Material Properties for Higher Efficiency Power Plant', in which E.ON contributes £300k.
- 'Advanced Materials for Low Emission Power Plant'.

In addition E.ON UK plc participates in the EPSRC's SUPERGEN I & II 'Conventional Power Plant Lifetime Extension (PLE) Consortium'.

The E.ON UK Power Technology Centre at Ratcliffe-on-Soar (Notts.) carries out materials related R&D activities in the following areas:

- Materials Engineering
- Power Plant Chemistry
- Plant Performance & Life Extension
- Boiler and Turbine Engineering
- Renewable Energy

- Technical support for E.ON UK Power Engineering Services, which carries out overhaul, repairs and performance upgrades on steam turbine rotors, cylinders, compressors and other components.

2.7.4.3. Metals Processors / Fabricators

Corus Engineering Steels (Rotherham and Stocksbridge)

Currently, Corus Engineering Steels' (CES) internal R&D related to fossil-fuel power generation, and carried out at Corus Swinden Technology Centre (Rotherham) and in plant, is focused on the development of new high temperature, creep resistant grade steels.

The current CES R&D spend is predominantly internal, but work is also supported at the University of Loughborough on Cr-containing, creep resistant steels (Profs. Roy Faulkner and Rachel Thompson) and the University of Leicester (Drs. Sarah Hainsworth & Andrew Strang).

In addition, CES supplies materials into the EPSRC SUPERGEN 'Conventional Power Plant Lifetime Extension (PLE) Consortium' project and CES is a partner in EU COST 536 programme.

Sheffield Forgemasters Ltd. (Sheffield)

Sheffield Forgemasters has increased its R&D spend to approximately £1.2M per annum (after grants), covering product and process development across all sectors into which the company supplies. The company supports external work at universities and RTOs.

Firth Rixson Forgings Ltd. (Various Locations)

Firth Rixson's current external R&D expenditure is < £50k per annum. The company respond to OEM customer materials requirements, which is complemented by significant in-house process developments, related to the processing of customer specified materials.

Firth Rixson support work at: The University of Sheffield on process modelling (Prof. Mark Rainforth, Dr. Brad Wynne), Cambridge University on ring-rolling (Dr. Julian Allwood), and the University of Birmingham on materials modelling (Prof. Roger Reed).

Special Metals Wiggin Ltd (Hereford)

Currently, Special Metals Wiggin Ltd. (Hereford) is not carrying out any specific in-house materials developments, although customer/OEM specified materials are subject to in-plant process development activities. For example, Special Metals has recently been involved in development work with Doosan Babcock Energy on large tube materials for ultra-super critical boiler applications (Inconel 740 & Nimonic 263).

Alcoa Howmet Ltd. (Exeter)

Alcoa Howmet's external R&D expenditure is approximately £50k per annum to support external initiatives. In addition, the company partners some customers and universities (eg, provision of materials for research, etc) in R&D activities.

2.7.4.3. Coatings Development Activities

The current trend is for more complex coatings - ie, a move away from single (layer) coatings such as MCrAlY bond coats to MCrAlY + aluminising, in combination with Thermal Barrier Coatings (TBCs). Activities of some of the UK's leading high temperature materials coatings companies are given below:

Sulzer Metco (UK) Ltd.

Currently, Sulzer Metco supports R&D activities at the Universities of Cambridge (Prof. Bill Clyne) and Cranfield (Dr. John Nicholls), and has its own R&D facilities outside of the UK (eg, in Switzerland).

Sulzer Metco is a partner in the Technology Strategy Board 'MACE' project (see above) and has previously participated in EU 'Framework' Programmes, although is not currently active in any such Programmes. However, the company is a partner in overseas R&D Programmes supported, for example, by the NRC (Canada) and ULIF (Germany). The company is also engaged in a development activity with a steam turbine OEM for steam turbine coatings.

Sermatech Ltd. (Lincoln & Ripley)

Currently, Sermatech supports R&D activities at the Universities of Birmingham (with Dr. Hugh Evans) and Cranfield (with Dr. Nigel Simms). Coatings development is largely carried out in the USA, but Sermatech is a partner in the Technology Strategy Board 'MACE' project.

The company's development priorities are led by aero engine requirements for higher temperature coatings for corrosion and oxidation protection. In addition, development work on Cr-free coatings (Cr VI replacement) is ongoing for environmental reasons.

Praxair Surface Technologies Ltd. (PSTL) (Swindon and Weston super Mare)

Development of thermal spray processes and powders is carried out primarily in the U.S headquarters in Indianapolis where specific programmes have supported major OEM's such as Rolls-Royce. Tribomet® type coatings and their applications are developed at PSTL's facility in Weston super Mare. Development programmes in support of major OEMs, such as Rolls-Royce and Siemens have been carried out in collaboration with a number of UK universities.

Monitor Coatings Ltd. (South Shields)

Monitor invests approximately 11% of turnover (approx. £3.5M in 2006) on research and development activities, and has taken part in EU FP projects such as the FP5 'SUPERCOAT' ('Coatings for Supercritical Steam Cycles') project led by Alstom, Germany

Other R&D activities include the HiCOAT project led by TWI, which is aimed at developing coatings for biomass incinerators, and with partners including E.ON UK. Monitor are also working with a steam turbine OEM to develop coatings for steam turbine applications.

2.7.4.4. Research & Technology Organisations (RTOs)

The National Physical Laboratory (NPL) is a partner in a number of the Technology Strategy Board Collaborative R&D Programmes, but is also supported by the National Measurements System for the following projects relevant to fossil fuel fired power generation:

- 'Key Measurements on In-situ Oxide scales'; April 2007 – March 2010; £385k.
- 'State of the art diagnostic measurement for lifetime management of critical parts in efficient energy generation'; April 2007 – March 2010; £402k.

TWI Ltd. has a number of Group Sponsored Projects (GSPs), or Joint Industry Projects (JIP) for the Power Industry, which are programmes of mutual interest to a number of organisations each contributing to fund the work. In addition, a number of projects within the TWI Core Research programme (CRP) are relevant to fossil fuel-fired power generation.

2.8. Summary

The following gives a summary of the status of the UK's fossil fuel fired power generation industry, with particular emphasis on materials and manufacturing inputs:

- Electricity generation from fossil fuel combustion constitutes more than 75% of the UK's electricity supply (2006 data).
- The closure of the coal and few remaining oil fired stations will result from implementation of 'The Large Combustion Plant Directive' (LCPD), which comes into effect in January 2008; the first constraint of which means that approximately 11GW of 'opted-out' coal and oil stations will close by the end 2015.
- It is estimated that since 1990, the UK has lost approximately 70% of the supply chain for components/plant into the power generation sector. This reduction in capacity has resulted from the construction of relatively few power stations over the past 10-15 years, and the resultant

need for suppliers to seek alternative markets, and from the acquisition of UK based OEMs by mainland European parent companies in particular.

- The materials supply chains for fossil-fired plant, whether conventional steam turbine or the more recent combined cycle plants, for example, are currently reliant upon 'inputs' from mainland Europe, in particular, although materials are also sourced in Japan and the USA.
- However, UK based companies maintain an extensive capability in the processing and fabrication of precision components for major fossil fuel fired plant (steam and gas turbines, pulverised fuel boilers, etc.) and could increase supply into this market, if the business conditions were favourable.
- In addition to Alstom Power Ltd.'s OEM capability for large steam turbines, UK based companies, such as Alstom and Siemens & non-OEMs such as the Wood Group, also offer an extensive steam turbine service capability (repair, refurbish, upgrade, retrofit, etc.). Of the world's four largest manufacturers of steam turbines, two (Alstom and Siemens) maintain significant capability in the UK.
- There are two UK based OEMs for land based gas turbines (Rolls-Royce and Siemens Industrial Turbomachinery Ltd.), which together serve the full range of power output requirements for simple cycle or CCGT applications.
- There are some gaps in the UK based materials supply chain for fossil fired power plant, which includes a lack of capability in the manufacture of seamless stainless & speciality steel tube for heat exchanger applications in boilers, gasifiers and Carbon Capture and Storage (CCS) systems. In addition, the only UK based manufacturer of seamless stainless and speciality steel pipe (Wyman-Gordon Ltd, Livingston) currently exports all its products.
- Thus, although a significant capability to manufacture components such as rotors, blades, discs, rings, casings, etc. for fossil-fired power generation exists, few UK based metals processors (eg, caster, forger, extruder, roller, etc.) now have the power generation sector as their major market (say 20% or more of turnover).
- Although the UK is home to a major supplier of boiler plant and related equipment (Doosan Babcock Energy), much of the materials inputs (seamless tubes, pipes, etc.) are sourced from overseas.
- As the strength of the supply chain has decreased, so the capacity of the industrial and academic base for research and development in materials for fossil-fired power plant has decreased accordingly.
- However, many R&D activities in fossil fuel fired power generation are world-class, and have an important contribution to make in the development of materials for high efficiency, low emission power plant (eg, Rolls-Royce plc, Alstom Power Ltd., Doosan Babcock Energy Ltd, Corus UK, E.ON UK plc, RWE npower plc, Universities of Cranfield, Cambridge, Loughborough, Birmingham and Nottingham).
- Public funding of fossil fuel fired power generation activities has received a considerable boost recently through the launch of the Governments 'Strategy for Developing Carbon Abatement Technologies for Fossil Use' and £35M of funding from the Technology Strategy Board for Carbon Abatement Technologies (CAT).

2.9. SWOT Analysis

The Strengths, Weaknesses, Opportunities and Threats for the UK, with emphasis on materials and manufacturing input to the fossil fuel fired power generation industry are given in Table 2 below:

<p style="text-align: center;">Strengths</p> <ul style="list-style-type: none">• Significant capability in design, construction and operation of fossil fuel fired power plant.• World leading OEMs in all major fossil fuel fired plant.• World leading fossil fuel fired plant materials expertise across both the academic and industrial sectors (alloy development and coatings).• World leading pilot scale test facilities (eg, burner and combustion test rigs).	<p style="text-align: center;">Weaknesses</p> <ul style="list-style-type: none">• Significant investment will be required to reinstate and / or develop capabilities to supply some critical components.• No UK based capability in induction bending of large diameter thick-walled pipes and in the manufacture of seamless, thin-walled stainless and alloy steel tubing and Ni-base alloy tubing.• A lack of skilled scientists / engineers with a strong background in materials.
<p style="text-align: center;">Opportunities</p> <ul style="list-style-type: none">• Possible that some UK companies would invest to increase their scope and capacity for components .• Companies could reinstate facilities and skills if the business case justifies.	<p style="text-align: center;">Threats</p> <ul style="list-style-type: none">• Competition from overseas suppliers.• Lack of investment in manufacturing capabilities; in particular, those associated with the manufacture of large forgings, seamless tube and large diameter pipework bending.• Very buoyant oil & gas and other sectors resulting in a lack of will of metals processors / fabricators to participate in power generation sector.• Loss of skills.

Table 2.2 - SWOT analysis for the UK's fossil fuel-fired power generation industry.

3. NUCLEAR ENERGY

3.1. The Nuclear Energy Market

Currently, nuclear energy provides approximately 16% of the world's electricity, from more than 440 reactors in 30 countries and with a total installed capacity of 372 GWe. In addition, 30 new reactors are under construction, equivalent to 7.5% of existing capacity, whilst over 80 are planned, equivalent to 24% of present capacity.

In 2006, UK nuclear plants generated 18% of UK electricity (69 TWh of 380 billion TWh net), compared with 36% from gas and 38% from coal. There are 19 UK reactors totalling approximately 11 GWe of capacity, although the actual operational capacity is lower. In addition, approximately 2% of UK electricity demand is met by imports of nuclear power from France, and so the overall nuclear contribution to UK electricity consumption is approximately 21%. Thus, nuclear power provides a significant proportion of the UK's 'baseload' electricity generation capacity.

As regards the future of nuclear power in the UK, in 2006, a review of the UK's energy policy was undertaken, which put replacement of the country's nuclear power stations firmly back on the national agenda, resulting from energy security concerns and the need to limit carbon emissions. Also, subject to the outcome of further consultation to October 2007, the Government gave clear support for investment by the private sector in nuclear power capacity, so that nuclear power could play a significant role in UK's energy future. The review also stated that any new plants would have to be financed and built by the private sector, with provision for internalised waste and decommissioning costs.

In June 2006, the UK's Health & Safety Executive (HSE), which licenses nuclear reactors through its Nuclear Installations Inspectorate (NII), suggested a two-stage licensing process, similar to that in the USA. Since then, the following have applied to the NII for generic design assessment (GDA, or pre-licensing) to be carried out by experts belonging to the nuclear regulators:

- Westinghouse Electric Company Ltd. (owned by Toshiba, Japan) for its 1,150 MWe, AP1000 Pressurised Water Reactor (PWR) design, based on its 2005 US design certification and supported by British Energy plc and E.ON UK plc.
- Areva NP (66% owned by Areva, France and 34% owned by Siemens, Germany), in conjunction with EDF (France), then applied for GDA of its 1,600 MWe European Pressurised water Reactor (EPR) design, which received French design approval in 2004. Areva will also involve five other European utilities interested in building it in UK: British Energy plc, E.ON UK plc, Iberdrola, RWE npower plc and Suez.
- GE-Hitachi Nuclear Energy for its ESBWR Boiling Water Reactor (BWR), supported by Iberdrola, RWE npower plc and British Energy plc.
- Atomic Energy of Canada Ltd. (AECL) for its ACR-1000 design.

Of the utilities, British Energy, which controls many of the likely sites for the new plants, has said that it would support all four GDA applications and that it is conducting its own review of reactor designs from the four vendors above. In addition, EDF has said that it wants to build several EPR plants in the UK and that it could build new nuclear plants by 2017, if planning procedures were improved and government decisions were made on wastes.

In this respect, there is significant global experience to show that modern nuclear reactors take around 5 years to construct. However, it would take several years in the UK to get to the point where the industry could start construction and overall it would take approximately 10 years to construct and commission a new nuclear power station.

3.2. The UK's Nuclear Reactors

In all, the UK has 12 nuclear power stations and 19 operational reactors, many of which are reaching the end of their life and are due to be decommissioned. It is estimated that by 2020 the current 19% of electricity generated via nuclear energy will be reduced to just 7% if they are not replaced, and current plans will see all but one plant, the Pressurised Water Reactor (PWR) at Sizewell B, retired by 2023.

Figure 3.1 below shows the locations of all of the UK's nuclear power plants.



Figure 3.1 - Nuclear power stations in the UK (from Department of Trade and Industry: Consultation Document, 'The Future of Nuclear Power', May 2007).

Further details on the nuclear reactors currently in operation in the UK are shown in Table 3.1 below.

Reactors	Type	Net capacity each	Start Operation	Expected shutdown
Oldbury 1 & 2	Magnox	217 MWe	1968	Dec 2008
Wylfa 1 & 2	Magnox	490 MWe	1971-72	Dec 2010
Dungeness B 1 & 2	AGR	545 MWe	1985-86	2018
Hartlepool 1 & 2	AGR	595 MWe	1984-85	2014
Heysham 1 & 2	AGR	615 MWe	1985-86	2014
Heysham 3 & 4	AGR	615 MWe	1988-89	2023
Hinkley Point B 1 & 2	AGR	620 & 600 MWe*	1976-78	2011 or 2017
Hunterston B 1 & 2	AGR	610 & 605 MWe*	1976-77	2011 or 2017
Torness 1 & 2	AGR	625 MWe	1988-89	2023
Sizewell B	PWR	1196 MWe	1995	2035
Total (19)		11,035 MWe		

* running at 70% power indefinitely.

Table 3.1 - Nuclear power reactors operating in the UK. (Courtesy of the World Nuclear Association: <http://www.world-nuclear.org/>)

Figure 3.2 shows the locations of all the UK's nuclear energy facilities: plants in operation, those undergoing decommissioning, experimental reactors, fuel plants, etc.

Nuclear Energy: Locations in the UK

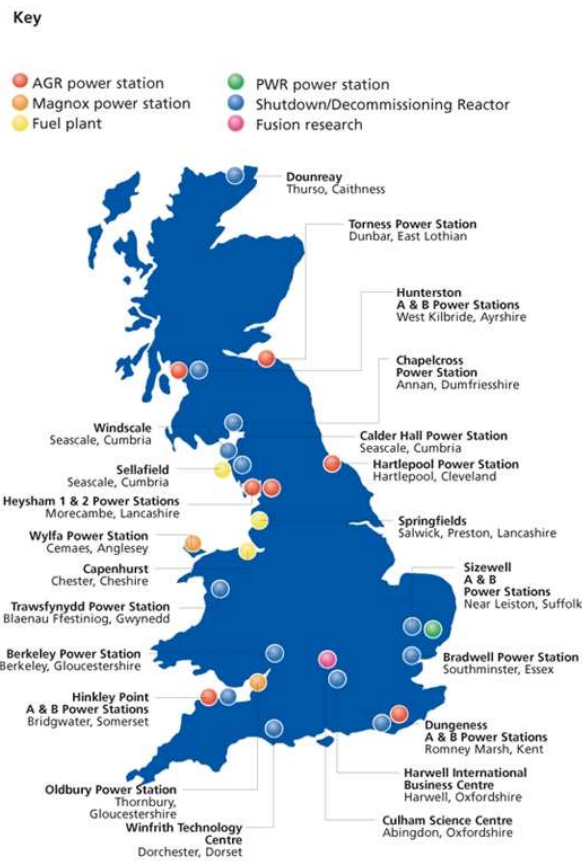

Figure 3.2 - Nuclear energy locations in the UK. (Courtesy of the Nuclear Industry Association (NIA): from 'Nuclear Energy, Past Present and Future', 2004. see www.niauk.org).

A detailed description of the operation of the various nuclear reactors is beyond the scope of this review. However, 11 Magnox stations were built in the UK, each with a unique design and the first was commissioned in 1956 at Calder Hall in Sellafeld, Cumbria. Magnox reactors use natural uranium metal fuel, with a MAGnesium Non-OXidising cladding. Both steel and concrete pressure vessels were used and the reactors are graphite moderated and are cooled with carbon dioxide. On economic grounds all Magnox reactors will be closed by 2011 and the last four in operation are at Wyfla (Anglesey, N. Wales) and Oldbury (Thornbury, Gloucs.) – see Figure 3.3.



Figure 3.3 - Schematic of the Oldbury Magnox reactor, commissioned in 1968. (Courtesy of 'The Science & Society Picture Library': <http://www.scienceandsociety.co.uk/>)

Fourteen of the UK's second generation, Advanced Gas-cooled Reactors (AGRs), were built on seven sites, starting up between 1976 and 1989 (Figure 3.4). The type of reactor, which is exclusive to the UK is also graphite moderated and carbon dioxide cooled, but uses enriched uranium oxide fuel, which is burned up to low levels (relative to Light Water Reactor (LWR) fuel). The AGRs were designed and built by private industrial nuclear power consortia as complete power stations.

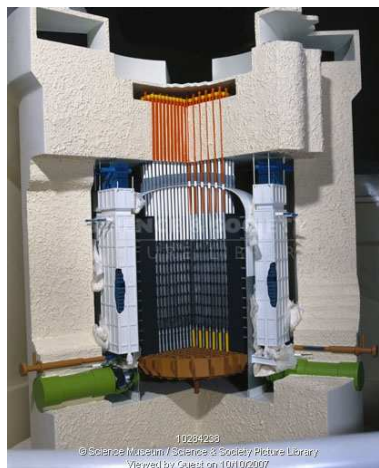

Figure 3.4 - Schematic of the Heysham II / Torness AGR, commissioned in 1988. (Courtesy of 'The Science & Society Picture Library': <http://www.scienceandsociety.co.uk/>)

In 1978, the decision was taken to build an initial (one of four planned) Pressurised Water Reactor (PWR), and a large Westinghouse unit was started up in 1995 at Sizewell B (Figure 3.5). In a PWR, water is used as both reactor coolant and the moderator, and the fuel is enriched uranium dioxide pellets, encapsulated in tubes of a corrosion-resistant zirconium alloy (Zircaloy). These fuel rods are then grouped in fuel assemblies, called fuel bundles, which are then used to build the core of the reactor. In a PWR, water is pumped under high pressure (to prevent boiling) through the core of the reactor, reaching a temperature of approximately 300°C. It is then used to boil other water in a separate circuit, to make steam.



Figure 3.5 - Schematic of the Sizewell B PWR , commissioned in 1995. (Courtesy of ‘The Science & Society Picture Library’: <http://www.scienceandsociety.co.uk/>)

The Sizewell B reactor is typical of much of the world capacity, but is newer and more complex than most PWRs.

In 2006, British Energy, the operating company of all of the UK’s AGR reactors and the PWR reactor at Sizewell B closed four AGRs at Hinkley Point B and Hunterston B (two reactors each), because of boiler degradation in the non-nuclear part of the plants. These reactors are now operating at approximately 60% capacity until March 2008, at which time, a decision will be made on possible life extension for the units, which will otherwise close in 2011.

Table 3.2 below shows the UK’s nuclear reactors decommissioned to date.

Reactors	Type	MWe each	Shut down
Berkeley 1 & 2	Magnox	138	1988-89
Bradwell 1 & 2	Magnox	123	2002
Calder Hall 1-4	Magnox	50	2003
Chapelcross 1-4	Magnox	49	2004
Dungeness A 1 & 2	Magnox	225	2006
Hinkley Pt 1 & 2	Magnox	235	2000
Hunterston A 1 & 2	Magnox	160	1989-90
Sizewell A 1 & 2	Magnox	210	2006
Trawsfynydd 1 & 2	Magnox	196	1993
Windscale	AGR	28	1981
Dounreay PFR	FBR	254	1994
Winfrith	SGHWR	92	1990
Total: 21			

Table 3.2 – Decommissioned power reactors in the UK. (Courtesy of the World Nuclear Association: <http://www.world-nuclear.org/>)

As mentioned above, many of the UK’s nuclear power stations are currently expected to close over the next two decades, and by 2025, 10.2GWe of nuclear generation capacity is likely to close (see Figure 3.6) based on published lifetimes. However, it is possible that the lives of the existing nuclear power stations could be extended and this would help mitigate the decline in low-carbon generation in the period towards the end of the next decade. In this respect, in December 2007, British Energy has announced that it will extend the lives of two nuclear reactors by five years, and the Hunterston B

station in North Ayrshire and the Hinkley Point reactor in Somerset will now continue operating until at least 2016.

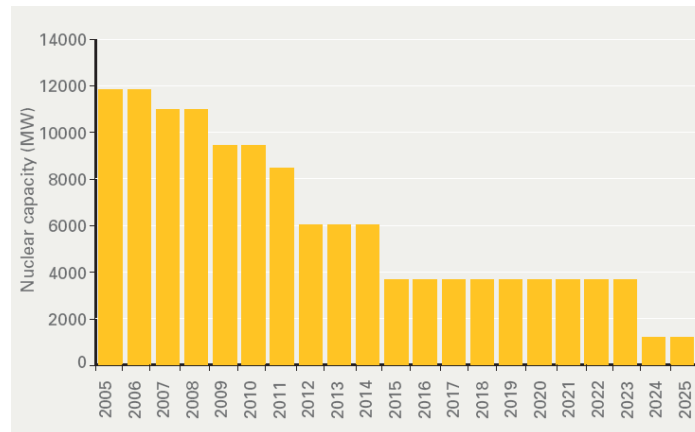

Figure 3.6 – Expected decline in nuclear generating capacity in the UK (from Department of Trade and Industry: Consultation Document, ‘The Future of Nuclear Power’, May 2007).

3.3. The UK’s Civil Nuclear Energy Industry

UK based companies have been active (leading) in the development of civil nuclear power for more than 50 years, and the UK maintains a significant capability in the design, construction and operation of nuclear power plant, and in full fuel cycle facilities, nuclear plant decommissioning and nuclear waste management.

The UK’s nuclear industry employs directly and indirectly approximately 80,000 people in the UK and earns the UK approximately £700M a year from overseas business (From Mott MacDonald Report to UKT&I, 2007). The UK’s nuclear industry is a major exporter of technology and skills and UK companies are actively engaged in collaborative projects with overseas bodies. UK companies are playing an increasingly important role as owner, operator, engineer, consultant, contractor, supplier and investor in the global nuclear energy industry (From Mott MacDonald Report to UKT&I, 2007).

Research by Cogent, the sector skills council, suggests that the UK’s nuclear industry and its supply chain employs 56,000 people directly, across 200 employers, although this figure includes those employed in the defence sector (eg, constructing, refitting and refueling of nuclear submarines and the Atomic Weapons Research Establishment, Aldermaston).

In 1996, industry deregulation resulted in the nuclear generating plants, apart from the Magnox plants, being transferred into the private sector, under British Energy, which maintains and operates all AGR and the PWR reactors, although subsequent restructuring during 2003-05 meant that the UK government (re-) owned 64% of British Energy. In May 2007, the government sold this down to 39%. Also, in 1996, the state-owned British Nuclear Fuels Ltd (BNFL) took ownership of all the Magnox power stations as well as the UK fuel cycle facilities. BNFL subsequently bought Westinghouse and other international nuclear engineering and services companies.

Since 1971, British Nuclear Fuels, Ltd. (BNFL) has operated the majority of the UK’s nuclear fuel cycle facilities. In 2004, BNFL became essentially a two-business company: managing Fuel Manufacture and Reactor Services through Westinghouse, and Nuclear Decommissioning and clean-up through British Nuclear Group (BNG); with the Spent Fuel & Engineering business unit and Magnox Generation becoming contractors to the Nuclear Decommissioning Authority (NDA). In 2006, BNFL gained government approval to sell BNG by tender in 2007, in a piecemeal fashion. The only part of BNG not for sale is Nexia Solutions Ltd., which will be the basis of the new National Nuclear Laboratory (NNL) at Sellafield.

The first part of the BNG disposal was the spin-off of Sellafield Ltd., which has a 5 year contract with the NDA to run and clean up the Sellafield site. Sellafield Ltd. is operating most of the former BNFL facilities, notably the THORP and Magnox reprocessing facilities and the new Sellafield MOX plant, under contract to the NDA.

In mid-2007, BNG sold its Reactor Sites Management Company (RSMC) business to Energy Solutions of the USA. The sale included Magnox Electric, a wholly-owned subsidiary of RSMC, which holds the contracts and licenses to manage ten Magnox nuclear sites, with 22 reactors in the UK to operate and decommission on behalf of the NDA.

Today, BNFL (British Nuclear Fuels plc) is the holding company for Sellafield Ltd., British Nuclear Group (BNG) Project Services and Nexia Solutions Ltd.

The UK has world leading experience in the decommissioning of nuclear power reactors and is currently engaged in an extensive decommissioning programme, which is the responsibility of the NDA. The NDA was set up and funded under the 2004 Energy Act, and is charged with cleaning up the UK's legacy of nuclear wastes on 22 nuclear sites, including 39 reactors, 5 fuel reprocessing plants as well as other fuel cycle and research facilities. Previously, these were the responsibility of BNG (the decommissioning and clean-up arm of BNFL) and the UKAEA, and in April 2005 NDA took over all designated liabilities and assets from those bodies. Thus, the NDA has full financial responsibility for management of all the public sector civil nuclear liabilities and assets under performance based contracts, and for the UK's waste disposal programme, which includes the existing UK Atomic Energy Authority (UKAEA) sites, originally used for nuclear energy research (eg, Harwell).

The UK has full fuel cycle facilities including major reprocessing plants and from the very early days of nuclear power generation in the UK, the UK has been self-sufficient in conversion, enrichment, fuel fabrication, reprocessing and waste treatment of imported Uranium. The nuclear fuel cycle provides the fresh fuel and the spent fuel services, either reprocessing or storage, for nuclear power stations. And approximately 20,000 people in the UK are employed in the production, reprocessing and storage of nuclear fuel and in waste handling in the UK.

The UK industry provides the processing of spent nuclear fuel from eight countries: Japan, Germany, Switzerland, Spain, Sweden, Italy, Netherlands and Canada.

UK companies are also involved in decommissioning projects overseas. A well trained and highly skilled workforce of approximately 15,000 people is employed in the operation and decommissioning of the UK's nuclear power stations.

Finally, it should be noted that all parts of the UK industry are subject to one safety regulator, the Health & Safety Executives' Nuclear Installations Inspectorate (HSE NII).

3.4. Overview of the UK's Nuclear Industry Materials Supply Chain

The primary nuclear industry operators are supported by a wide variety of supply chain companies, such as engineering and construction contractors, fabricators of specialist equipment, manufacturers and specialist service providers.

However, the UK's materials supply chain(s) for nuclear power plant has been eroded quite considerably over the past 15 years or so, a consequence of the majority of UK's nuclear power 'fleet' now being between 20 and 50 year old, such that any future nuclear power plant build will be turnkey plant (pressure vessels and steam generators and a few other reactor core items, etc.) from those companies currently undergoing the generic design assessment (GDA, or pre-licensing) – eg, Westinghouse and Areva NP.

An excellent, recent review of the supply chain capability of UK industry to support the delivery of a UK nuclear new build programme has been carried out by the 'New Build Working Group' (NBWG) of the Nuclear Industry Association (NIA). The NIA is the representative body for the British civil nuclear

industry, representing over 120 companies operating in all aspects of the nuclear fuel cycle (for more details, see www.niauk.org). The key findings of this review are summarized below.

3.4.1. Key Findings of the NIA UK Capability Review

In the NIA's NBWG review, several key assumptions were made, which included the following:

- The Pressurised Water Reactor (PWR), the most widely used reactor technology in the world (accounting for over 60% of global nuclear power stations) was considered as the reference reactor type for the study and the AREVA NP European PWR (EPR) and the Westinghouse Advanced Passive PWR (AP1000) were selected as the reference designs.
- A programme of five twin Nuclear Power Plants (NPPs) would be built over approximately 20 years on or adjacent to existing nuclear power station sites to replace the current nuclear generated electricity supply capacity of around 10 GW.

The report focused on the UK's capability in three broad areas:

- Programme Management and Technical Support
- Civil Engineering Construction
- Plant and Equipment

Of the above, 'Plant & Equipment' are of most relevance to the materials supply chain, and typically comprise approximately 55% of a nuclear power plant build, with 'Civil Engineering and Construction', and 'Project Management and Technical Support' accounting for approximately 30% and 15%, respectively. However, some elements of 'Civil Engineering & Construction', such as the supply of materials and construction of the Nuclear Island, Turbine Island and Balance of Plant are also relevant, as will be described below.

The NIA NBWG assessed UK capability against the delivery of approximately sixty 'packages' of equipment or services, which comprise a complete nuclear power plant. The Group also considered current (early 2006) capability with that which may be available in approximately five years time, with sufficient investment and training to regenerate capability lost over recent years. A period of five years was chosen as this is the likely timeframe prior to the initiation of any new build programme. A summary of the findings of the analysis is shown in Figure 3.7 below.

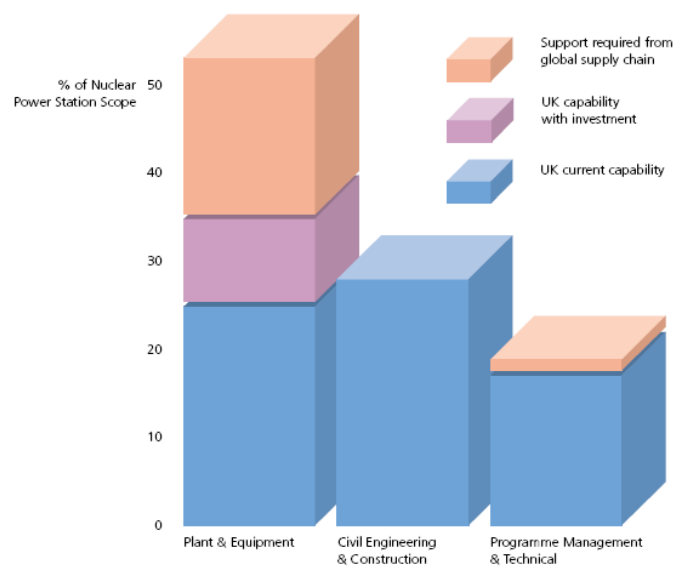

Figure 3.7 - NIA NBWG analysis of UK industry capability to support a new nuclear power plant build. From 'The UK Capability to Deliver a New Nuclear Build Programme, the NIA, March 2006. (Courtesy of the NIA: <http://www.niauk.org/>).

The NIA NBWG analysis suggests that the UK supply chain has a strong capability in most of the areas required to support a new nuclear build programme (see Figure 3.7 above), and UK industry could supply around 70% of the total requirements for such a programme. Furthermore, the Group estimated that with some investment in facilities and the training of new personnel, this capability could be increased to a little over 80%. This capability is currently being used to support existing nuclear power plants and new fuel cycle plant, and in decommissioning and waste management activities. In addition, it is being applied to non-nuclear projects which utilise similar skills, and the construction activities and much of the plant and equipment are similar to those of a nuclear power plant.

However, the NBWG also noted that in an internationally competitive environment, the capability to supply does not necessarily mean that UK companies will supply. In addition, the Group identified some significant gaps in UK capability, which will be discussed in detail below. In particular, the manufacture and supply of steam turbines, generators and reactor pressure vessels will be from overseas at least for the first of any new nuclear power plants.

The specific UK capabilities in the three broad areas indicated above are described in the following sections.

3.4.1.1. Programme Management and Technical Support

Programme Management and Technical Support covers activities such as the overall management, commercial and technical direction and regulatory and planning activities required to deliver a new nuclear power station from inception through to commissioning and operation readiness.

Regarding the UK's capability in this area, the NBWG concluded the following:

- Less than 2% of the UK capacity for Programme Management and Technical Support would be required for a new nuclear build programme.
- The capability and resources required to project manage and technically support the new nuclear build programme can readily be provided by UK industry.
- Resources would likely not be provided by a single company, but by a grouping of companies.
- A nuclear new build programme would provide continuity of work for UK industry rather than overstressing UK capability, following the completion of major infrastructure projects such as those associated with the 2012 Olympics.

3.4.1.2. Civil Engineering and Construction

The NBWG recognised that there are differences in the quantities of materials for construction and in the approach to construction between the two reactors considered. Thus, the Westinghouse AP1000 uses a modular construction approach which involves remote production of structural modules followed by shipping to site and assembly, whereas the Areva NP EPR is built on site.

However, regarding the UK's capability in this area, the NBWG concluded the following:

- A new nuclear build programme equates to less than 0.5% of the annual value of UK construction industry output.
- All elements of the civil construction (nuclear and turbine islands, balance of plant and supporting infrastructure) could be undertaken by UK companies.
- As above, a nuclear new build programme would provide continuity of work for UK industry rather than overstressing UK capability, following the completion of major infrastructure projects such as those associated with the 2012 Olympics.
- Materials required for the civil and structural aspects of the construction of the new power plants are readily available within the UK market.
- A relatively small percentage of normal UK annual outputs would be required, for example less than 1% of cement and aggregate output and less than 4% of structural steel production.
- The availability of large capacity cranes and self-propelled transporters, for the lifting and transportation of either individual components such as reactor vessels, steam generators, turbine rotors, etc. and reactor modules will need extensive forward planning.

Of specific interest from a materials viewpoint is the availability of structural and reinforcing bar steel. Considering the former, it is estimated that each new reactor site will require approximately 50,000 tonnes of structural steel, which can comfortably be accommodated by the UK's steelwork manufacturing, fabrication and erection industries.

The UK's major supplier of structural steel is Corus, with a manufacturing capacity of approximately 1.2 million tonnes per year in the UK, 50% of which is currently exported, produced at their Scunthorpe and Teesside facilities. However, although the structural steel requirement for a new nuclear build programme can be met from within the UK, steel is likely to be sourced from overseas, from mainland Europe in particular.

In addition, it is estimated that each new power station would require approximately 60,000 tonnes of steel reinforcement bar for use in reinforced concrete. The UK retains significant capacity and capability to produce the reinforcement and cable required for the construction of new nuclear power plants, and the requirement represents approximately 6% of annual UK consumption (approximately 1 million tonnes) and approximately 9% of annual UK production (approximately 660,000 tonnes) of reinforcement bar.

Major producers of reinforcement bar are Celsa Steel UK in Cardiff (parent Celsa Group, Spain), Thames Steel Ltd. in Sheerness and Alpha Steel (parent Satico Ltd., Switzerland) in Newport. Corus at Scunthorpe also produce relatively small quantities of non-ribbed coil suitable for reinforcing bar.

3.4.1.3. Plant & Equipment

Plant and Equipment for a nuclear power plant includes the reactor pressure vessels and ancillary equipment such as tanks, pipework, and the more conventional turbines, generators and switchgear. Much of the ancillary equipment is similar to that required for non nuclear (eg, fossil fuelled power and chemical plant) and significant experience has been developed and maintained through these non-nuclear projects.

Regarding the UK's capability in this area, the NBWG concluded the following:

- UK companies could supply approximately 50% of the Plant and Equipment with current facilities and resources; with some investment, this could increase to approximately 70%.
- With increasing world demand, it is possible that some UK companies would invest to increase their scope and capacity for a UK new build programme and for potential export.
- Companies which have redirected their efforts since the last nuclear build could reinstate facilities and skills if the business case justifies.
- Limited world capacity to produce critical components such as forgings and reactor pressure vessels, and the associated long lead times for such components, may effect the ability to deliver a UK new build programme.

Almost all of the Plant and Equipment for Sizewell B could be supplied by UK companies, although not all components were supplied by UK companies. As will be discussed below, the components / plant which could not be supplied by UK companies at that time were some of the large forgings and the reactor pressure vessel.

As regards current capability, there are several UK based companies with manufacturing facilities and experience capable of supplying a large number of the components required for a nuclear power plant. For example, some UK companies are world leaders in the supply of equipment to overseas nuclear industries and there are also world leading UK companies currently supplying Plant and Equipment to the non-nuclear energy and civil engineering projects, both within the UK and overseas.

3.4.2. The Nuclear Fuel Cycle

The global reserves of Uranium are considered to be sufficient to meet the growing demand for nuclear power. Although most of the UK's uranium supplies come from Australia, the World's largest producer is Canada (see Table 3.3 below).

The International Atomic Energy Agency (IAEA) and the Organisation for Economic Cooperation and Development (OECD) estimate that approximately 4.7 million tonnes of known uranium resources can be mined for less than \$130/kg, together with further reserves which would be more expensive to recover. Based on 2004 levels of nuclear electricity generation, these reserves would last for approximately 85 years.

Uranium ore goes through a complex milling process and is sold in a form known as yellowcake, (U_3O_8). The uranium oxide is then converted at an enrichment plant into uranium hexafluoride (UF_6 – a radioactive gas) and 'fissile' U235. The enriched uranium is then converted into a solid uranium dioxide (UO_2) powder and pressed into small pellets, which are used in fuel assemblies.

The quantities of fuel involved for a nuclear plant are much lower than for conventional, fossil-fuelled power stations. Thus, whereas a coal-fired power station could consume several million tonnes of coal per annum, a modern 1,000 MWe nuclear station will typically require a few tens of tonnes of fuel for each re-fuelling operation, which takes place every 12-18 months.

Country	2002	2003	2004	2005	2006
Canada	11604	10457	11597	11628	9862
Australia	6854	7572	8982	9516	7593
Kazakhstan	2800	3300	3719	4357	5279
Niger	3075	3143	3282	3093	3434
Russia (est)	2900	3150	3200	3431	3262
Namibia	2333	2036	3038	3147	3067
Uzbekistan	1860	1598	2016	2300	2260
USA	919	779	878	1039	1672
Ukraine (est)	800	800	800	800	800
China (est)	730	750	750	750	750
South Africa	824	758	755	674	534
Czech Repub.	465	452	412	408	359
India (est)	230	230	230	230	177
Brazil	270	310	300	110	190
Romania (est)	90	90	90	90	90
Germany	212	150	150	77	50
Pakistan (est)	38	45	45	45	45
France	20	0	7	7	5
Total world	36 063	35 613	40 251	41 702	39 429
tonnes U_3O_8	42 529	41 998	47 468	49 179	46 499

Table 3.3 – Uranium production from mines in tones. (Courtesy of the World Nuclear Association: <http://www.world-nuclear.org/>).

As mentioned above, the UK has full fuel cycle facilities for conversion, enrichment, fuel fabrication, reprocessing and waste treatment, and facilities for the UK's nuclear fuel cycle are as follows:

- A 6,000 tonnes / yr conversion plant is located at Springfields (nr. Preston, Lancs.), managed by Toshiba (Westinghouse Electric Company) under contract to the Nuclear Decommissioning Authority (NDA). Springfields manufactures nuclear fuel products for the UK's nuclear power stations and for international customers. Fuel manufacture is scheduled to continue until 2023. In addition to fuel manufacture, Springfields also undertakes decommissioning activities.

- Enrichment is undertaken by Urenco at Capenhurst (nr. Chester, Cheshire). Urenco is part owned by the British government.
- Fuel fabrication of Magnox, AGR and PWR fuel is carried out at Springfields, and other PWR fuel is bought on the open market. It is assumed that fuel and fuel assemblies for a future build will be supplied by the reactor vendor, although this may not be the case.
- Mixed Oxide (MOX) fuel fabrication for export is carried out at Sellafield (Seascale, Cumbria).
- TVEL Corporation (Russia) are contracted to supply fuel pellets, with fuel assemblies made by Areva NP (France and Germany), to British Energy's Sizewell B PWR plant.
- Reprocessing is undertaken by British Nuclear Group (BNG) at Sellafield, under contract to the Nuclear Decommissioning Authority. Operations at Sellafield include treatment of fuels removed from nuclear power stations; Mixed Oxide (MOX) fuel fabrication; and storage of nuclear materials and radioactive wastes.

Through the above facilities, the UK should be capable of supplying fuel(s) for a new build programme.

3.5. The Supply Chain for Major Components of a PWR

3.5.1. Introduction

In this section, the supply of specific, major components required for the construction of a PWR based nuclear power plant is considered. A simple schematic of a PWR is shown below in Figure 3.8 and a schematic of the Areva NP EPR is shown in Figure 3.9 and an excellent overview of the main components of the Areva NP EPR can be downloaded as a brochure from its website (<http://www.areva-np.com/>).

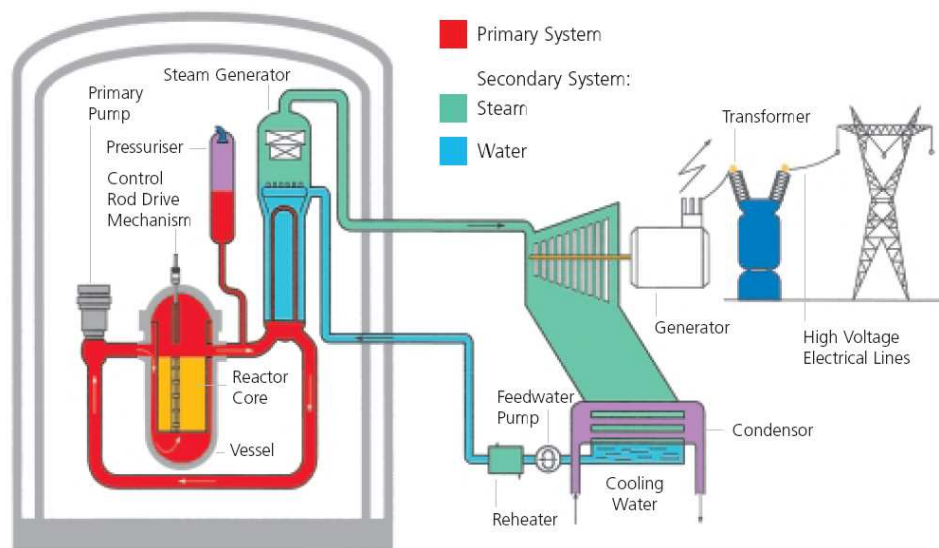

Figure 3.8 – Operational diagram of a typical PWR (from ‘The UK Capability to Deliver a New Nuclear Build Programme’, the NIA, March 2006. (Courtesy of the NIA: <http://www.niauk.org/>).

A typical PWR nuclear power station has two main water circuits, the Primary circuit, which removes heat from the reactor, and the Secondary (complete steam cycle) circuit.



Figure 3.9 - Schematic of the Areva NP EPR (Courtesy of Areva NP: <http://www.aveva-np.com/>).

A summary of the status of the materials supply chain(s) for nuclear power generation components (within the nuclear island only), which includes information from the NIA NBWG review, together with information gathered during the course of this study, is presented below:

3.5.2. Containment Building

The nuclear island or the Nuclear Steam Supply System (NSSS) sits within the containment building which, for the Areva NP EPR, consists of a ferritic steel liner (the Reactor Building Liner (RBL)), approximately 6mm in thickness, covered by a reinforced concrete shell. The Westinghouse AP1000 uses thicker steel plate (50mm in thickness), but is also surrounded by a reinforced concrete shell. Both are considered to be relatively routine constructions, requiring expertise in the welding and inspection of the steel plates.

The containment liner for Sizewell B was fabricated in the UK and the manufacturing capability still exists.

3.5.3. Reactor Pressure Vessel (RPV)

The RPV is a high structural integrity vessel which contains the nuclear fuel elements and operates at a pressure of 160 bar and at a temperature of 300°C. The RPVs of the Westinghouse AP1000 and the Areva NP EPR are similar, and for a 1000 MWe reactor, the RPV will typically weigh around 500 tonnes and be approximately 4 metres in diameter, 10 metres in height and approximately 200mm thick.

The main components of a RPV are large forgings (see Figure 3.10 below) which, because of their size, can be manufactured in only a few places throughout the world. In this respect, there has been insufficient recent demand within the UK to justify either the supply of the large forgings for RPVs or the fabrication of large RPVs, but if UK or global demand were to develop, as forecast, and with (significant) investment, the situation could change.

Specifically, both the RPV shell and the closure head are fabricated from ferritic steel forgings (ASME SA 508 Class 3, low alloy Mn-Mo-Ni steel), which are clad on the inside with stainless steel weld metal for corrosion resistance. The large mid-section ring forging is welded to the spherical bottom section of the vessel and the pressure vessel head is bolted onto the top of the pressure vessel.

The critical importance of the availability of very large forgings for nuclear power plant applications was emphasised towards the end of 2006, when Areva NP acquired SFARSTEEL, one of the world's leading manufacturers of large, forged parts and owner and operator of the 40,000 tonne Creusot Forge in Le Creusot, France.

Vincent Maurel, President and CEO of AREVA NP, described the acquisition as: "a strategic move, at a time when the new builds market in the nuclear power industry is picking up again, and forged parts are essential in ensuring the quality and prompt delivery of nuclear equipment at competitive prices".

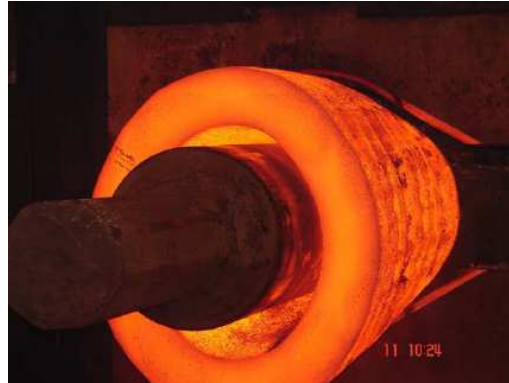

Figure 3.10 - Large Reactor Pressure Vessel (RPV) forging. (Courtesy of Areva NP).

As regards subsequent fabrication of RPVs from forged and other components (Figure 3.11), the UK based companies Doosan Babcock and Rolls Royce Marine's subsidiary Derby Specialist Fabricators Ltd., have manufactured approximately 30 of the smaller RPVs for nuclear submarine PWRs. In addition, the manufacturing processes of RPVs are similar to those of steam generator pressure vessels, which have been manufactured by both Doosan Babcock and Rolls Royce Marine / Derby Specialist Fabricators Ltd.

Thus, although the skills exist in Sheffield Forgemasters Engineering Ltd for production of large forgings and in Doosan Babcock/Derby Specialist Fabricators Ltd for manufacture of RPVs, no UK companies are set up currently to produce civil RPVs of around 1000 MWe capacity.

To develop a manufacturing capability, entailing mechanical handling (load of up to 500 tonnes), welding and inspection equipment, would require significant investment, which for UK manufacturers would require very clear indications of the level of UK and global demand.



Figure 3.11 - Large Reactor Pressure Vessel (RPV) forging with nozzles. (Courtesy of Areva NP).

Currently, it is believed that companies which could supply forgings for RPVs include:

- Mitsubishi Heavy Ind. (Japan): rings and heads.
- Japan Steel Works (JSW) (Japan): rings and heads.
- Creusot Forge (Le Creusot, France): rings and heads.
- Doosan Heavy Industries and Construction, Ltd. (Korea): rings and heads.
- Skoda (Czech R): rings and heads.
- OMZ (Russia): rings and heads.
- China First Heavy Industries (China): rings and heads.

The following companies can manufacture RPVs using the above forgings:

- Mitsubishi Heavy Industries, Ltd. (Japan)
- Areva NP (France, Germany)
- Doosan Heavy Industries & Construction (South Korea)
- Ansaldo (Italy)
- Skoda (Czech Republic)

The current global manufacturing capacity for RPVs, of approximately 1,000 MWe capacity, is estimated to be approximately 15 per annum. The current global capability to supply large forgings is potentially a limiting factor on a new build programme, although increased world market demand would likely lead to an increase in large forging capacity; for example, in China and the USA.

3.5.4. Reactor Pressure Vessel Head

As mentioned above, the closure head, containing all the penetration for control rods, is bolted to the top of the RPV and is machined from a single large forging (see Figure 3.12 below).



Figure 3.12 - Nuclear Pressure Vessel Head (Courtesy of Areva: René Quatrain).

As mentioned above, the closure head is fabricated from a single ferritic steel forging. In 2006, the head of the Sizewell B reactor was replaced. The replacement head was manufactured by Areva and was the same as the original head (ASME SA 508 Class 3, low alloy Mn-Mo-Ni steel), but because of stress corrosion concerns, used Inconel 690 welds between the head and control rod guide tubes, instead of the Inconel 600 welds, which were used on the original head.

The so-called Integrated Head Package comprises the Reactor Pressure Vessel Head forging, the Shroud Assembly, the Missile Shield and the Control Rod Drive Mechanisms (CRDMs). A CRDM is designed to insert, withdraw or maintain the position of the reactor control rods from which neutron absorbers are suspended (used, for example, to facilitate shutdown).

The CRDMs are attached to the top of the RPV Closure Head Forging via nozzles welded onto the forging (see Figure 3.13 below), using Inconel 600 or, more recently, Inconel 690 filler. There are typically around 70-90 CRDMs dependent on reactor type and size, each controls a cluster of control rods (CRs), which comprises typically around 20 rods. The CRs are typically supplied by the reactor vendor.

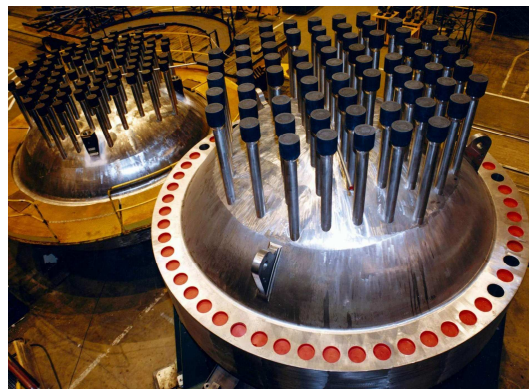

Figure 3.13 – A reactor pressure vessel head showing Control Rod Drive Mechanisms (CRDMs) (Courtesy of Areva: René Quatrain).

The CRDMs and control rods for the Sizewell B PWR were supplied by Framatome (now Areva NP). The CRDMs and CRs of naval PWRs are similar in concept and design to those of civil reactors and have been supplied by Rolls Royce Marine / Derby Specialist Fabricators Ltd. and forgings from Sheffield Forgemasters Ltd. In addition to Rolls Royce Marine, companies having significant experience and current capability in the processes involved in the supply of CRDMs include:

- Assystem UK Ltd (ex-Inbis Ltd. and part of the Assystem Group, France), Preston, Lancs.
- NIS Ltd, Chorley, Lancs.
- Doosan Babcock (ex-Mitsui Babcock), Renfrew, Scotland
- Weir Strachan & Henshaw, Bristol
- Alstec Ltd, Whetstone, Leics.

In addition, there are likely to be several other UK based companies with the skills and manufacturing capabilities to supply and maintain CRDMs and CRs, and there are several overseas competitors in the field, including Areva NP (France, Germany).

3.5.5. Reactor Pressure Vessel Internals

The RPV Internals support the fuel assemblies within the RPV and some act as shielding / radiation reflectors. The support internals consist of assemblies of precision machined rods, tubes and plates, manufactured from steels of various grades, and the he shielding internals are large rings of stainless steel placed in the gap between the RPV and the core.

For the Sizewell B PWR, Westinghouse supplied the internals directly to Framatome (now Areva NP) for installation into the RPV. UK based companies which could supply, although not doing so at present, include:

- Doosan Babcock , Renfrew, Scotland
- NIS Ltd, Chorley, Lancs.
- Alstec, Whetstone, Leics.
- Assystem UK Ltd (ex-Inbis Ltd. and part of the Assystem Group, France), Preston, Lancs.
- Bendalls Engineering Ltd., Carlisle.

Manufacturing and assembly of the RPV Internals package, one per reactor, does not constitute a significant volume of work and there are sufficient resources within the companies listed above to cope with the resource demand for a new power station.

3.5.6. Steam Generators

The function of the steam generator (SG) is to transfer the from the primary reactor cooling system to the secondary feedwater / steam which drives the steam turbines. Steam generators for PWRs are similar for all current designs and are vertical, u-tube heat exchangers contained within a ferritic steel pressure vessel. For the Areva NP design there are four SGs, equivalent to ~400MWe each, whereas the Westinghouse AP1000 has only 2 SGs, equivalent to ~600 MWe each.

Each steam generator weighs approximately 500 tonnes and is approximately 21-25 metres in height and 4.0-4.5 metres in diameter with a vessel wall thickness of approximately 100 mm (Figure 3.14).



Figure 3.14 – Steam Generator fabrication at Mitsui (now Doosan) Babcock, Renfrew, for Sizewell B. (Courtesy of Doosan Babcock Energy Ltd.)

The steam generator pressure vessel is manufactured from large ferritic steel rings and hemispherical forgings (see Figure 3.15) which, like the large forgings for RPVs, are produced by only a few companies globally. Inside the SG pressure vessel, the complex components include: steam / water separators and drying equipment and Inconel 690 u-tubes welded onto a thick tube plate.



Figure 3.15 - Lower pressure boundary Steam Generator sub-assembly. (Courtesy of Areva NP).

Doosan Babcock (ex-Mitsui Babcock) procured all components and manufactured and assembled the four steam generators for Sizewell B and Rolls Royce Marine has manufactured steam generators for UK's nuclear naval fleet. Within the UK, it is believed that only Doosan Babcock have the potential to reinstate this former capability to manufacture steam generators. However, there is currently no UK company set up to manufacture SGs.

As mentioned above, the need for large, high quality forgings is a critical aspect of steam generator supply and only one UK Company, Sheffield Forgemasters Engineering Ltd., could supply the ring forgings for the steam generator pressure vessel.

It should also be noted that there is currently no UK based supplier of seamless Inconel 690 tubing, or indeed, any other nickel based alloy and stainless steel tubing.

There are a few companies overseas currently supplying SGs for new build or for replacement programmes, which include:

- Areva NP (France)
- Equipos Nucleares (Spain)
- Mitsubishi Heavy Industries Ltd.(Japan)
- Babcock & Wilcox (Canada)
- Shanghai Boiler Works (China)
- Doosan Heavy Industries and Construction, Ltd. (Korea)

It is forecast that if the world demand for new nuclear plants increases as expected and the SG replacement programmes continue as present, then there will be a shortage of capacity for SG manufacture. This will cause current suppliers to increase their throughput and some former suppliers to consider re-opening their manufacturing facilities.

3.5.7. Pressuriser

In a PWR system, the pressuriser is used to control the pressure in the reactor cooling system (the primary circuit) so that boiling does not occur within the reactor. It contains water in its lower part and steam in its upper part plus an electrical heater / spray system to vary the volumes of steam/water and pressure relief valves to protect the system against overpressure.

Pressurisers are medium sized pressure vessels, manufactured from ferritic steel forgings, which are subsequently stainless steel clad for corrosion protection and which are approximately 2.5 metres in diameter and approximately 140mm thick, weighing 80-100 tonnes (see Figure 3.16).



Figure 3.16 - Erection of a Pressuriser in a reactor building.
(Courtesy of Areva NP: <http://www.aveva-np.com/>).

Forgings for pressurisers are much smaller than those for RPVs and Steam Generators and so could be supplied from the UK. Sheffield Forgemasters Ltd. and Wyman-Gordon are capable of producing them. In addition, subsequent pressuriser fabrication could be carried out by Rolls Royce Marine / Derby Specialist Fabricators Ltd. and Doosan Babcock, together with other companies with facilities for welding, machining, lifting, etc. of medium weight / sized pressure vessels. The pressuriser for Sizewell B was manufactured by NEI-ICL, which no longer exists.

3.5.8. Pumps and Valves

The environment in which some pumps and valves operate within a Nuclear Steam Supply System (NSSS) is very demanding (high temperature and pressure). The main reactor coolant pumps circulate pressurized water within the Primary Circuit to the steam generator whilst the main reactor feed-water pumps supply hot water to the steam generators within the Secondary Circuit. Without the latter, heat could not be effectively removed from the reactor or steam produced. The maintenance intervals for these pumps are 6-8 years.

In addition, there are a number of other pumps which operate on either a continuous or intermittent basis, but which must have exacting standards of integrity – ie, they must work when needed.

Although there has been no new UK build since Sizewell B, Clyde Pumps Ltd. (incorporating Weir Pumps Glasgow), a world leader, manufacture and supply all nuclear and turbine island pumps into the international nuclear industries and power generation sectors, and supply currently spares to the Magnox, AGR and Sizewell B power stations. In addition, Sulzer Pumps (UK) Ltd. (part of the Sulzer Group, Switzerland) has a UK based manufacturing capability in Leeds and also supply into the global nuclear industries market.

As in the case of pumps, a nuclear reactor requires a wide variety of high integrity valves, etc. for the Primary and Secondary Cooling Circuits and elsewhere within the nuclear island. In the supply of these components, the UK again has world leading suppliers such as Weir Valves & Controls (UK), Ltd. (Huddersfield, W. Yorks) and Thompson Valves, Ltd. (Poole, Dorset).

Large micro-alloyed steel valve castings have been produced by Goodwin Steel Castings, Ltd. (Stoke-on-Trent).

3.5.9. 'Generic' Fabricated Metal Components

Large forgings and pipework (pipes, elbows, tees, etc.) are used in various applications within the nuclear island, and some information on the materials and suppliers of these components is described below:

Large Forgings

From the descriptions of some of the major components and as highlighted earlier in this report, the supply of very large forgings is critical to any new nuclear power plant build and such forgings are used for the manufacture of Reactor Pressure Vessels (RPVs), steam generator pressure vessels and tubeplates, pressurisers, and for the primary circuit pipework, as well as steam turbine and turbine generator rotors.

The companies which it is believed could supply ring forgings for RPVs and steam generators, and large head forgings were listed above (Section 3.5.3). In addition to those companies, there are a number of others which can produce large steam turbine rotor forgings and these include Saarschmiede (Germany) and Kobe Steel (Japan).

For Sizewell B, most of the large forgings were supplied by Japan Steel Works (JSW) and from Creusot Forge in France, with UK companies supplying some of the smaller forgings.

Of significant concern is the limited global manufacturing capacity of some critical components which are reliant upon these large forgings. As mentioned above, the world capacity for RPVs is estimated at approximately 15 per annum and JSW, for example, have reported a full order book for forgings for RPVs out to 2010.

Within the UK, Sheffield Forgemasters have the capability to forge the considerably smaller components for the nuclear marine sector (eg, ring and head forgings for RPVs and SGs) and have also supplied some forgings for civil reactors overseas. They also have the capability to produce the large steel castings required. However, the company would need significant investment to create a capability for the forging of civil nuclear RPVs and SGs.

Nuclear Steam Supply System (NSSS) Pipework

The extensive pipework, both within the nuclear island and from the nuclear island to/from the turbine house is a critical element of a nuclear power plant. Although there are significant differences between the volume and dimensions of pipework needed in the Westinghouse and Areva NP designs, which is linked to factors such as the number of steam generators in the two designs (see Section 5.6 above), both require tens of kilometers of pipework.

The Primary Loop pipework is very specialized and comprises forged austenitic stainless steel pipe and cast or forged elbows (see schematic in Figure 3.17 below). The high pressure, safety-related pipework (high integrity pipework) consists of pipework which connects the steam generators to the turbines and other pipework which makes up the various safety systems. Finally, there is a considerable amount of conventional lower pressure pipework associated with ancillary plant.

The scale of some of the pipework is illustrated by the so-called hot cold and crossover legs of the Primary Loop of the Areva NP EPR (see Figure 3.17). Thus, the seamless hot and cold leg sections are produced by forging solid austenitic steel ingots of approximately 115 tonnes (hot leg) and 160 tonnes (cold leg), and the crossover leg is forged from a 75 tonne hollow austenitic stainless steel ingot. The pipe sections are also welded using an austenitic stainless steel filler metal (ER 316L).

Both the high integrity pipework and the more conventional pipework is similar to that found in fossil-fired power plants and chemical plant, for example, and is manufactured from drawn pipe and cast or forged components (elbows, tees, end caps, etc.) in austenitic stainless and ferritic steels.

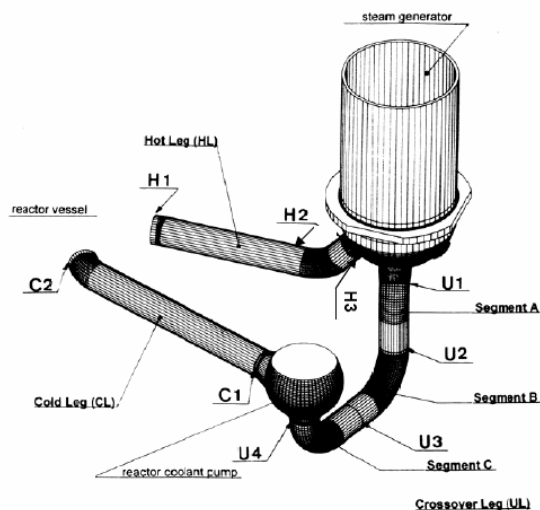

Figure 3.17 - Schematic diagram of Primary Loop (or Circuit) pipework for the Areva NP EPR.
(Courtesy of Areva NP: <http://www.epr-reactor.co.uk/>).

The volume/length of these pipes is large and it would not be conceivable that one or even a few companies could meet the total volume requirements.

Although there are many induction bending machines in the UK and the EC, there are not many for large diameter, thick pipes because the demand has not been present in recent years. This is a potential bottleneck for UK supply, but it could be met by supply from Germany, if necessary.

For the Sizewell B PWR, Matsui (now Doosan) Babcock manufactured the Primary Loop pipe spool pieces from forgings from Creusot Forge, France, and castings from Camerons UK, Scunthorpe (subsequently known as Wyman-Gordon and now Bradken Ltd.). Other UK companies which could have supplied forged pipe and cast elbows are Sheffield Forgemasters Ltd. and Firth Rixson respectively.

The high integrity, safety related pipework for Sizewell B was manufactured and installed by the BPA Joint Venture which no longer exists and Matsui Babcock carried out pipe bending. The conventional lower pressure pipework was manufactured by several smaller companies.

UK companies with a capability to manufacture components for the high integrity pipework are given below.

- Castings and ring forgings: Sheffield Forgemasters Ltd., Sheffield
- Seamless heavy wall extruded pipe: Wyman-Gordon, Livingston, Scotland
- Castings: William Cook Cast Products (Sheffield), Goodwin Steel Castings, Ltd. (Stoke-on-Trent), Bradken Ltd. (Scunthorpe).
- Various pipework fittings: Proclad International Forging, Ltd., Livingston, Scotland.
- Induction Bending: Proclad Induction Bending Ltd, Glenrothes, Scotland
- Cold Bending: Shaw Group UK Ltd., Derby

Some of these companies could also supply some of the Primary Loop forgings and castings, and Doosan Babcock can fabricate the Primary Loop and high integrity pipework, as was the case for Sizewell B. In addition, other companies can produce small forgings, etc. for pipework and small components (eg Wyman-Gordon and Proclad International Forging Ltd., both of Livingston, Scotland).

There is currently no UK based capability in induction bending of large diameter thick-walled pipes and this would have to be reinstated, or a new nuclear build could be supplied from mainland Europe. The UK also has no capability to supply seamless, thin walled stainless and alloy steel tubing and Ni-base alloy tubing, and supply of such tube is from mainland Europe, from Sandvik (Sweden), Valinox

Nucléaire (France), DMV (Germany), Tubacex (Austrian facility of Spanish parent company), and Tenaris (Italy).

3.5.10. Supply of Some Other Nuclear Industry Components

In this section, the supply of components into the UK's nuclear industry, which are not mentioned above, are described. The components and suppliers listed is certainly not exhaustive, but gives an indication of additional capabilities which exist within the UK to support the current and any future civil nuclear power plant build, and waste management and decommissioning activities.

- Corus Process Engineering in West Cumbria is one of the world's leading designers and suppliers of low alloy, C-Mn-Ni, steel flasks for the transport of nuclear materials.
- ATI Allvac Ltd. (Sheffield) has a 'life of station' contract to supply R35 and R35S (Nb or Ti stabilized Fe-25Ni-20Cr) supports for AGR fuel rods. These complex supports are fabricated from a combination of: machined 25mm solid bar, cold rolled precision strip for end caps and spacers, and small drop forgings.
- Special Metals Wiggin Ltd. (Hereford) supplies some Ni-base alloy tubing and Ni alloy rods for the manufacture of tie bars, which suspend fuel rods within the reactor.
- Nuclear grade graphite for the Magnox and AGRs was supplied by Anglo Great Lakes Ltd. (Newcastle) and British Acheson Electrodes, Ltd. (later known as Union Carbide and subsequently part of Dow Chemicals, Inc.), and can now be supplied by both Morgan Crucible and Areva NP.

3.6. UK R&D Activity in Nuclear Materials

Nuclear fission related R&D in the UK has declined steadily over the past 20 years or so, and since the 1980's, public investment in nuclear fission R&D has dropped by more than 95% and the industrial R&D skill base has decreased by more than 90%. Figure 3.18 below shows a best estimate of the decline in UK personnel engaged in nuclear R&D since 1980. The decline has been so marked that the UK is now the only country with a significant nuclear capability which has failed to maintain a government sponsored laboratory engaged in nuclear reactor design or R&D related to the full nuclear fuel cycle. On a global basis, whilst this trend is not uncommon, other countries are now investing significantly in nuclear R&D skills.

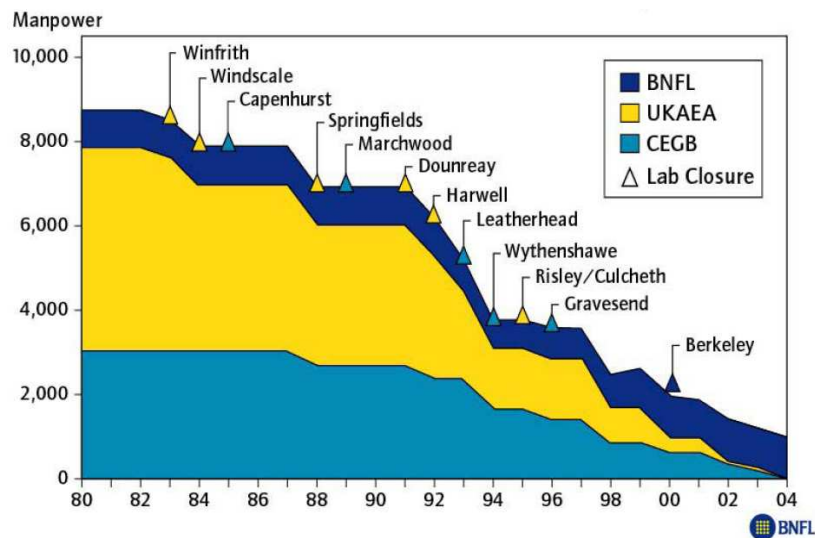

Figure 3.18 - Best estimate of the decline in UK R&D personnel (from a presentation given by Prof. R. Clegg at the NIA 'Energy Choices' Conference, London, on 2 December 2004).

However, the UK still has leading expertise across both the academic and industrial sectors, and with the world class facilities at the newly established Sellafield Technology Centre (see below). In particular, the North West has a very strong skills and R&D base.

A database of activities related to Nuclear R&D can be found at The UK Energy Research Centre (UKERC) Energy Research Atlas: Nuclear Fission, at <http://www.ukerc.ac.uk/Home.aspx>.

3.6.1. British Energy plc

Within British Energy plc, there are about 10 people actively involved in Materials R&D. However, the precise expenditure on materials specific R&D (of a total of approximately £13M in 2006/07) is difficult to quantify as the company does not have Materials as a separate R&D competency area.

British Energy's current R&D priorities are Advanced Gas Cooled Reactor (AGR) life extension, maintenance of key skills, understanding of key components (eg, graphite core, boilers), and the company has ongoing activities with high materials content in structural integrity and graphite related R&D, and the company estimates that there is approximately £1M spent on steels related research and approximately £1.5M related to graphite activities.

In addition, British Energy has Strategic R&D Alliances with the Universities of Manchester, Bristol Strathclyde and Imperial College. Other service providers include: AMEC NNC, Serco Assurance Ltd., the Electric Power Research Institute (EPRI, USA) and Doosan Babcock Energy Ltd.

3.6.2. Nexia Solutions Ltd.

Nexia Solution Ltd. (formerly NSTS, BNFL R&D Division) operates facilities on behalf of the Nuclear Decommissioning Authority (NDA), on three nuclear licensed sites. These include the only facilities in the UK capable of carrying out research and development on highly radioactive nuclear material and large-scale uranium work. Nexia Solutions Ltd. employs approximately 800 people working at five facilities, as follows

- Technology Centre, Sellafield:
 - Supports the activities of 300 scientists and technologists.
 - Specific activities include decontamination development on real plant materials, mixed oxide (MOX) fuel and plutonium research, waste treatment and characterisation research work, and physics, chemistry and materials science based activities.
- Test Rig Facilities, Sellafield:
 - Complements the Nexia Solutions Workington facilities with a non radioactive test rig facility and a Vitrification Test Rig (VTR).
- Technology Centre, Springfields:
 - Accommodates approximately 150 people.
 - Specific activities include low-radioactivity uranium research and development, powder processing and fuel pelleting research.
- Nexia Solutions Windscale:
 - Primarily utilised to support clean-up of Sellafield site and to undertake irradiated fuel and materials examination for commercial customers.
 - Carries out non-destructive and destructive examination of a wide range of active materials.
- Nexia Solutions Workington (Test Rig Activities):
 - Supports non-radioactive remediation and decommissioning activities at Sellafield.
 - Nexia Solutions runs the facility with NIS Ltd.

The BNFL 'Research Alliances' have been formed between Nexia Solutions (BNFL) and selected University departments at Manchester (Materials Performance and Radiochemistry), Sheffield (Immobilisation Science) and Leeds (Particle Science & Chemistry). Currently, there are 120 researchers engaged on projects supported by these 'Research Alliances'. About half of the researchers are based at Manchester University, which has fairly recently established the Dalton Nuclear Research Institute to develop a programme of post-graduate level nuclear education and training for nuclear science.

3.6.3. The Dalton Nuclear Institute (University of Manchester)

The Dalton Nuclear Institute, an interdisciplinary nuclear research centre, was established at the University of Manchester in 2005, with aims which include: support for the development of expertise to underpin the UK's nuclear clean-up programme, and the maintenance and development of skills for any future new build programme.

Within the Dalton Nuclear Institute, the Materials Performance Centre (MPC) carries out (nuclear) materials specific activities, and research areas of the MPC include: corrosion, structural integrity, cladding materials (Zr, etc.), modelling (deformation and failure processes), fuels development. The Centre was established in 2002, with funding in the first year of £755k, which rose to £4M in 2005/6. The MPC has approximately 35 staff and approximately 30 research students.

- The Materials Performance Centre attracts considerable private sector funding and has been awarded a total contract value to date of £18M for projects running until 2010. Currently, the MPC has approximately 65 projects running with major funders as follows: EPSRC (£775k), MoD (£650k), Rolls-Royce (£625k), University of Manchester (£600k), NDA (£400k), British Energy (£300k), Nexia Solutions (£225k), Serco (£200k), EdF (£100k), EU (£60k), HSE (£50k), Westinghouse (£50k), Other (self/govt., £50k).

The Dalton Nuclear Institute is also home to the Nuclear Graphite Research Group (NGRG), which was established in 2001. Research within the NGRG involves the study of nuclear graphite material and graphite component behaviour and the research encompasses graphite related aspects of the new Generation IV Very High Temperature Reactor (VHTR) as well the present reactor designs such as AGR, Magnox, RBMK (Russian reactor) and High Temperature Reactor (HTR).

The NGRG has attracted funding of over £3.5M from organisations including the HSE (Nuclear Safety Division), British Energy Generation Ltd, British Nuclear Group, Nexia Solutions Ltd., the UKAEA, the European Commission and the EPSRC.

The Dalton Nuclear Institute also leads a Nuclear Engineering Doctorate (Nuclear Eng.D) degree, which is offered by a consortium of UK universities, and with total funding of approximately £5M. The partners in the Eng.D are Imperial College London, and supported by the universities of Bristol, Leeds, Sheffield and Strathclyde.

3.6.4. The National Nuclear Laboratory (NNL) and the Northwest Nuclear Research Centre

In October 2006, the Secretary of State announced that subject to contractual terms being agreed, the Government expects that there will be a UK National Nuclear Laboratory (NNL). It will be based around the British Technology Centre and Nexia Solutions Ltd. in Sellafield, West Cumbria.

In January 2007, it was announced that a major new nuclear research facility, the Northwest Nuclear Research Centre (NNRC), is to be established in Cumbria with £20M of initial funding from The University of Manchester's Dalton Nuclear Institute and the Nuclear Decommissioning Authority (NDA), which will see each organisation invest £10M over a seven-year period.

The Centre will initially house approximately 60 staff and postgraduate students, and will be built on the Westlakes Science and Technology Park, near Whitehaven in West Cumbria. It will have close links with the Nexia Solution's British Technology Centre (BTC) at Sellafield and to the NNL.

3.6.5. Keeping the Nuclear Option Open (KNOO)

Funded through the 'Towards a Sustainable Energy Economy Programme' of Research Councils UK, KNOO is a four-year, £6.1M initiative (start date 1st October 2005), established to maintain and develop skills relevant to power generation through nuclear fission. It represents the single largest commitment to fission reactor research in the United Kingdom for more than thirty years.

The grant has been awarded to a consortium of researchers from Imperial College London, the University of Manchester, Cardiff University, University of Sheffield, University of Bristol, University of Leeds and the Open University. The universities are working with BNFL, who have contributed £0.5M, and other stakeholders which include the Atomic Weapons Establishment, British Energy plc, the Department for Environment, Food and Rural Affairs, the Environment Agency, the Health and Safety Executive, Doosan Babcock, the Ministry of Defence, Nirex, AMEC NNC, Rolls-Royce plc and the UK Atomic Energy Authority.

The KNOO Programme is divided into four Work Packages (WPs) are as follows:

- WP1: Fuel, thermal hydraulics and reactor systems (Leader: Dr Simon Walker, Imperial College London).
- WP2: Materials performance and monitoring reactor conditions (Leader: Prof. Andrew Sherry, University of Manchester).
- WP3: An integrated approach to waste immobilisation and management (Leader: Prof. Simon Biggs, University of Leeds).
- WP4: Safety and performance for a new generation of reactor designs (Leader: Prof. Tony Goddard, Imperial College, London).

From a materials perspective, WP3 is of most interest, although there are activities within the other WPs which have a strong materials input; in particular, activities within WP4, which is focused on Advanced (Generation IV) reactor design, in which advanced fuel systems research is carried out.

The activity themes within KNOO WP3 include the following:

- Remote structural interrogation and monitoring tools.
- Finite element and self consistent models to assess materials.
- Mechanical understanding and predictive models of stress corrosion cracking.
- Mechanical performance of nuclear cladding and structural materials.
- The behaviour of graphite.

3.6.6. Miscellaneous Nuclear Materials R&D

The EPSRC currently has a call for proposals in the field of Nuclear Waste Management & Decommissioning.

Ongoing UK based Nuclear Materials R&D activities include:

- University of Manchester (Dr. Michael Preuss): coordinating a Zr alloy research programme, with Westinghouse Electric Co, Oxford University and the Open University.
- Oxford University (Prof. George Smith): Zr cladding related activities and radiation damage in W-Re alloys for Nuclear Fusion applications.
- Oxford University (Dr. Mike Jenkins & Prof. Steve Roberts): Multi-scale modelling of dual phase stainless steels, model Fe-Cr alloys and W for Nuclear Fusion applications, with UKAEA Culham Laboratory.
- Oxford University (Prof. Patrick Grant): W coating of steel substrates for Nuclear Fusion W diverter applications, and Environmentally assisted cracking in a range of ferro-alloys
- Oxford University (Dr. Mike Jenkins): Various studies related to radiation damage
- Oxford University (Prof. Alfred Cerezo): 3D Atom Probe studies of Cu precipitation in RPV steels, and Studies of W-Re Irradiation..
- Loughborough University (Prof. Roy Faulkner) 'Development of Reduced Activation ODS Steels for Fusion Reactor First Wall Applications', with Culham Laboratory.
- University of Birmingham (Prof. John Knott): activities related to the fracture of nuclear materials.
- The Open University (KNOO activities).
- Imperial College (KNOO activities).

The Universities of Liverpool and Edinburgh, Serco Ltd. and the UKAEA are partners in the EU FP6 programme, PERFECT (Prediction of Irradiation Damage Effects on Reactor Components).

TWI Ltd. (Abington, Cambs.) has been active in the development of joining and fabrication technologies for the nuclear sector for many years. TWI's experience covers the joining and fabrication of reactor pressure vessels and internals, steam generators, primary and secondary piping, waste encapsulation systems, etc., for a range of reactor types, including Magnox reactors, AGRs and PWRs. TWI assists the nuclear industry in the following areas: plant fabrication and refurbishment, safety and integrity, repair, and decommissioning and waste storage.

3.6.7. Nuclear Fusion R&D

The International Thermonuclear Experimental Reactor (ITER) programme recently announced that the experimental fusion reactor would be constructed at Cadarache, near Aix-en-Provence, France. This is an international project to construct a 500 MW experimental fusion reactor and will be jointly funded by China, the EU, Switzerland, Japan, Korea, Russia and the USA.

Design will begin in 2006 and construction is expected to be completed by 2016 at a cost of \$4.5 billion. In parallel, an International Fusion Materials Irradiation Facility (IFMIF) is also planned which is the materials test facility for ITER components and materials. To establish IFMIF is expected to cost an additional \$1 billion.

The UKAEA's Culham Science Centre is at the forefront of Nuclear Fusion research and development, and details of the materials related activities (eg, irradiation damage and phase transformations in Fe-Cr and W alloys) can be found at the Culham website: <http://www.fusion.org.uk/index.html>.

TWI is actively involved in Nuclear Fusion related R&D through the development of specialist, on-site, electron beam welding technology.

Serco Ltd., Nexia Solutions Ltd., National Nuclear Corporation Limited and the University of Manchester are partners in the EU FP6 programme RAPHAEL (ReActor for Process heat, Hydrogen And ELectricity generation). This project addresses the viability & performance of the Very High Temperature Reactor (VHTR) and the selection and qualification of materials for very high temperature components, graphite internals and the reactor vessel are key areas of the Project.

In addition to those ongoing at UKAEA Culham, some ongoing UK university based activities on materials for Nuclear Fusion applications are listed above in Section 3.6.6.

3.7. Nuclear Industries Specialist Skills

A discussion of issues associated with the skills required to support any future nuclear build is beyond the scope of this review and will only be touched upon briefly. However, although the capabilities in terms of equipment, etc. may be available to offer significant support to a large element of any future nuclear power plant build, it will not be an insignificant task to build up the required resources (skills) within the timescale for licensing and contract awards; within a period which is likely to be no longer than 5 years.

As mentioned previously, research by Cogent, the Sector Skills Council, estimates that approximately 56,000 people work in the nuclear industry in the UK, about 40,000 of them are in science, engineering and technology occupations. They conclude also that the current skills status of the nuclear industry is generally sound, although there are skills gaps, which will widen unless action is taken now.

Cogent successfully applied for funding to create a National Skills Academy for Nuclear (NSAN) in October 2006. The employer-led NSAN will seek to deliver a coherent skills strategy that will address the needs of the wider nuclear industry, including decommissioning and power generation.

If private sector companies in the UK proposed to build new nuclear power stations, the industrial skills base will have to be strengthened, through education and training of an existing and a new workforce. Clearly, this will require companies to train their own workforce and support from Government, universities, etc.

As part of the 'Towards a Sustainable Energy Economy' programme, the EPSRC has provided funding of about £1M to a 'Nuclear Technology Education Consortium' to provide masters-level and continuing professional development training for the nuclear industries.

As mentioned above, the EPSRC has also agreed a future collaboration on research and training activities in nuclear technology and engineering. The first action is a Centre in Nuclear Engineering under the Engineering Doctorate scheme with funding of £5M from EPSRC and contributions anticipated from private and public sector partners. As also mentioned previously, the University of Manchester has established the Dalton Institute which aims to be at the forefront of nuclear education and research.

3.8. Summary

The following gives a summary of the status of the UK's nuclear industry, with particular emphasis on materials and manufacturing:

- In 2006, UK nuclear plants generated 18% of UK electricity, compared with 36% from gas and 38% from coal. In all, the UK has 12 nuclear power stations and 19 operational reactors, totalling approximately 11 GWe of capacity, many of which are reaching the end of their life and are due to be decommissioned.
- The UK's nuclear industry employs directly and indirectly approximately 80,000 people in the UK and earns the UK approximately £700M a year from overseas business.
- The UK maintains a significant capability in the design, construction and operation of nuclear power plant, and in full fuel cycle facilities, nuclear plant decommissioning and nuclear waste management.
- The UK has full fuel cycle facilities for conversion, enrichment, fuel fabrication, reprocessing and waste treatment, which should be capable of supplying fuel(s) for a new nuclear build programme.
- However, the UK's materials supply chain(s) (plant & equipment) for nuclear power plant has been eroded quite considerably over the past 15 years or so, a consequence of the majority of UK's nuclear power 'fleet' now being between 20 and 50 year old.
- It is estimated that the UK supply chain has a strong capability in most of the areas required to support a new nuclear build programme, and UK industry could supply around 70% of the total requirements for such a programme; a little over 80% with some investment and training.
- This capability is currently being used to support existing nuclear power plants and new fuel cycle plant, and in decommissioning and waste management activities, and to non-nuclear projects which utilise similar skills.
- All elements of the civil construction (nuclear and turbine islands, balance of plant and supporting infrastructure) could be undertaken by UK companies.
- There are several UK based companies with manufacturing facilities and experience capable of supplying a large number of the components required for a nuclear power plant. These companies are world leaders in the supply of equipment to overseas nuclear industries and / or to non-nuclear energy and civil engineering projects.
- UK companies could supply approximately 50% of the Plant and Equipment with current facilities and resources, and with investment, this could increase to approximately 70%.
- With increasing world demand, it is possible that some UK companies would invest to increase their scope and capacity for a UK new build programme and for potential export. Companies

which have redirected their efforts since the last nuclear build could reinstate facilities and skills if the business case justifies.

- Limited world capacity to produce critical components such as forgings, for Reactor Pressure Vessels (RPVs), steam generator pressure vessels and for primary circuit pipework, as well as large steam turbine and turbine generator rotors, and the associated long lead times for such components, may affect the ability to deliver a UK new nuclear build programme.
- Currently, no UK companies are set up to produce civil RPVs – forging and subsequent fabrication.
- Currently, there is no UK based capability in induction bending of large diameter thick-walled pipes and the UK also has no capability to supply seamless, thin walled stainless and alloy steel tubing and Ni-base alloy tubing for nuclear island applications.
- Nuclear fission related R&D in the UK has declined steadily over the past 20 years or so, and since the 1980's, public investment in nuclear fission R&D has dropped by more than 95% and the industrial R&D skill base has decreased by more than 90%.
- However, the UK maintains leading nuclear materials expertise across both the academic and industrial sectors, with key initiatives such as The Dalton Nuclear Institute (University of Manchester), the EPSRC's 'Keeping the Nuclear Option Open' (KNOO), The National Nuclear Laboratory (NNL), the Northwest Nuclear Research Centre and Nuclear Fusion activities associated with the International Thermonuclear Experimental Reactor (ITER) concentrating UK efforts.
- It will take significant effort to build up the required resources (skills) within the timescale for licensing and contract awards; within a period which is likely to be no longer than 5 years.

3.9. SWOT Analysis

The Strengths, Weaknesses, Opportunities and Threats for the UK, with emphasis on materials and manufacturing input to the civil nuclear industry are given in Table 3.4 below:

<p style="text-align: center;">Strengths</p> <ul style="list-style-type: none"> • Significant capability in design, construction and operation of nuclear power plant, and in full fuel cycle facilities, nuclear plant decommissioning and nuclear waste management. • World leading companies currently supplying to marine nuclear and overseas civil nuclear industries. • World leading companies currently supplying to sectors such as Oil & Gas, Defence, Chemicals and petrochemicals, which require similar capabilities and skills. • Companies with experience in supplying to previous nuclear power plant builds. • World leading nuclear materials expertise across both the academic and industrial sectors. 	<p style="text-align: center;">Weaknesses</p> <ul style="list-style-type: none"> • No significant nuclear power plant build in the UK since Sizewell B. • Significant investment will be required to reinstate and / or develop capabilities to supply some critical components. • No UK companies set up to produce civil RPVs – forging and subsequent fabrication. • No UK based capability in induction bending of large diameter thick-walled pipes and in the manufacture of seamless, thin-walled stainless, alloy steel and Ni-base alloy tubing. • Steady decline of nuclear fission related R&D.
<p style="text-align: center;">Opportunities</p> <ul style="list-style-type: none"> • The private sector (utilities) appears to have a commitment to nuclear power in their future energy portfolios. • Possible that some UK companies would invest to increase their scope and capacity for a UK new build programme and for potential export. • Companies could reinstate facilities and skills if the business case justifies. 	<p style="text-align: center;">Threats</p> <ul style="list-style-type: none"> • Competition from overseas suppliers already in nuclear power plant supply chains. • Lack of investment in manufacturing capabilities; in particular, those associated with the manufacture of large forgings, seamless stainless steel and alloy steels, and large diameter pipework bending. • Significant effort needed to build up the required resources (skills) within the timescale for licensing and contract awards.

Table 3.4 - SWOT analysis for the UK's civil nuclear industry.

4. WIND POWER

4.1. The Wind Power Market Opportunity

The global installed wind generating capacity is now approximately 78,000 MW, compared with just 100 MW in 1980, with approximately 16,000 MW of new capacity to be installed in 2007 (Figure 4.1), and with annual global manufacturing market of €20 billion annually, increasing at about 33% per year. Overall, global demand will increase to approximately 24,000 MW per annum in 2020.

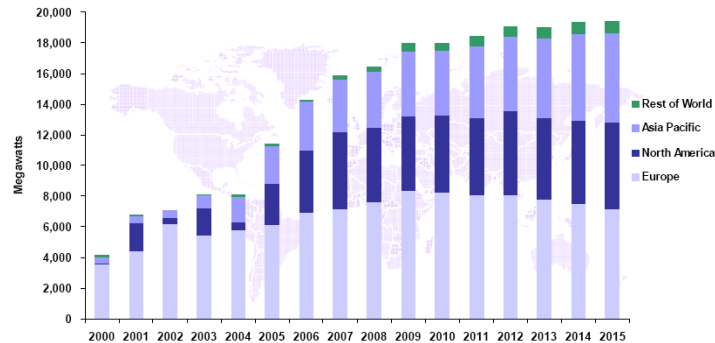

Figure 4.1 - Global wind power capacity increase by year. (Courtesy of Emerging Energy Research: http://www.emerging-energy.com/emerging_markets.html).

In 2006, approximately half of the new capacity installed globally was in Europe, with a total of 7,558 MW of new wind power capacity, an increase of 23% on 2005. Europe's cumulative total has now reached more than 48,000 MW of installed wind generating capacity (see Figure 4.2).

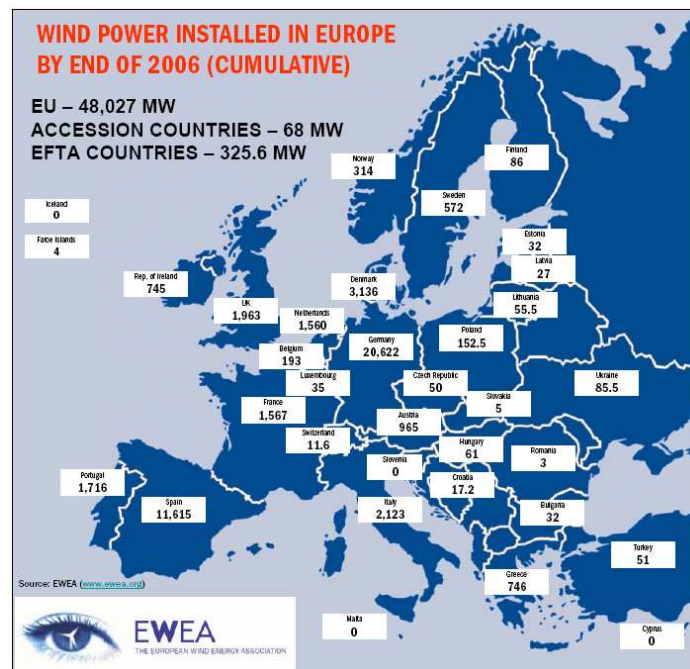

Figure 4.2 - Installed wind generating capacity in Europe at the end of 2006 (Courtesy of the European Wind Energy Association (EWEA): <http://www.ewea.org>).

Wind power is currently supplying approximately 1.5% of the electricity generated in the UK, with approximately 2,200 MW of installed capacity as of August 2007, with almost one third of this capacity being installed in 2006 (see Table 4.1 and Figure 4.3).

Year	Capacity Installed (MW)	
	Total	Offshore
2004	250	60
2005	440	90
2006	630	90

Table 4.1 - UK wind generating capacity installed in 2006.



Figure 4.3 - Status of UK wind farm development (Courtesy of the British Wind Energy Association (BWEA): <http://www.bwea.com/ukwed/google.asp>).

However, the pace at which wind generating capacity is being installed is increasing rapidly, and there is currently 1,400 MW of new capacity under construction, 557 MW of which is offshore (see Table 4.2).

Wind Farms	Capacity (MW)		
	Onshore	Offshore	Total
In Operation	1,874	304	2,178
Under Construction	841	557	1,398
Consented	1,744	2,106	3,850
In Planning	8,211	2,689	10,900

Table 4.2 - Status of UK wind farm development (data from UK Wind Energy Database (UKWED), British Wind Energy Association (BWEA)).

The UK Government's announcement in December 2003 that it intended to raise the level of the Renewables Obligation (RO) beyond the 10.4% set for 2010/11, to increase year on year to 15.4% in 2015/16, and with an aspiration of 20% by 2020, greatly improved the investment case for wind. The UK's wind resource is immense, and the combined potential for offshore and onshore wind generation is estimated at 100 GW. Most commentators believe that wind power will supply approximately three quarters of the 10% renewables requirement by 2010 – ie, approx. 7-8,000 MW.

The UK has the best offshore wind resources in the world and offshore wind power development is now a key part of UK's renewable policy. In order to regulate the development of offshore wind, the Crown Estate, the body which controls the coastal waters around the UK, conducted two rounds of offshore licensing. In the first of these, Round 1, applications were invited to develop wind farms consisting of up to 30 turbines, and thirteen licences were awarded (with a total capacity of approximately 1500 MW).

Round 2 of the Crown Estate's licensing allowed proposals for wind farms of unlimited size, with fifteen projects given initial approval (with a total of 7,169 MW). Maps showing Rounds 1 and 2 wind farm locations are given in the Wind Power Appendix .

A total of 8.4 GW of offshore wind capacity is forecast for installation over the period to 2009 and the UK is forecast to have one third of all capacity installed in the period from 2004-2009 (see Table 4.3 below).

Country	2000	2001	2002	2003	2004	2005	2006	2007	2008	2009	2005-2009
Belgium							42	145	130		316
Canada							4		700		704
China								50		100	150
Denmark		40	163	213					200	200	400
Finland								5	104		109
France								29			29
Germany					4.5	4.5	198	384	438	771	1,797
Ireland				25				167		190	356
Japan					1.2						0
Netherlands							99	120			219
Spain										250	250
Sweden		21					125	142	18		285
UK	4	0	0	60	60	180	270	424	668	1655	3,197
USA								468	140	2	610
Grand Total	4	61	163	299	66	184.5	738	1,934	2,397	3,168	8,421

Table 4.3 – World offshore wind capacity (from 'Scroby Sands Supply Chain Analysis', A Report to Renewables East by Douglas-Westwood Limited and ODE Ltd., Commissioned by the DTI DWL Report Number 334-04, July 2005).

As mentioned above, the global wind energy market is expanding rapidly and is creating opportunities for employment through the export of wind energy goods and services. Currently, the global wind industry has an estimated annual turnover of £5.5 billion, 84% of which is based in Europe. In the UK, wind energy is the fastest growing energy sector and over 4,000 jobs are sustained by companies working in the sector. The DTI estimated that Round 2 of offshore wind developments alone could create an additional 20,000 jobs in the UK.

A recent report by AEA Energy & Environment for Scottish Enterprise identified products and services which Scottish companies could offer to the wind power industry, with a potential market of more than £3.3 billion in the UK to 2012 (<http://www.scottish-enterprise.com>). The value of construction was estimated at £1,440M, whilst product development alone was estimated at £320M, turbine components at £1,360M and operation and maintenance at £200M. The report also indicated that growth in the sector is out-stripping the supply of turbines, thus creating opportunities for UK based (in this case Scottish) companies to gain market share. This will be discussed in more detail in a later section of this report.

In addition to large scale wind power generation, the DTI estimated that by 2050, up to 6% of UK's electricity generation could be produced from small wind energy generation.

4.2. The Wind Turbine Market

The world's four largest turbine manufacturers supplied almost 75% of all global capacity installed in 2006 and the top six manufacturers supplied approximately 90% of all capacity (see Figure 4.4 below). The world's largest manufacturer is Vestas (Denmark) with a 28% market share. Siemens (Denmark) currently has the largest market share of the UK wind energy market with 44% of all new, installed capacity (see Table 4.4), although of current capacity (as of August 2007), approximately 40% was installed by Vestas (including NEG Micon turbines).

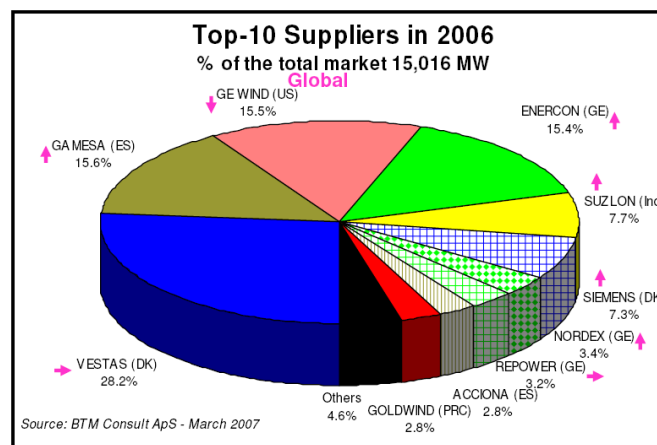

Note: In 'Others', Spain's Ecotècnia was acquired by Alstom in June 2007.

Figure 4.4 - Wind turbine manufacturers global market share in 2006. (Courtesy of BTM Consult ApS).

Wind Turbine Manufacturer	Market Share (%) or Market Position		
	2005	2006	2007
Siemens	44	49	# 1
Vestas	30	27	# 2
GE Wind Energy	18		will supply
Gamesa	5		will supply
Enercon	3	8	will supply
REpower	0.5	15	will supply
Nordex			will supply

Note: REpower is now owned by Suzlon.

Table 4.4 - Turbine Manufacturers – UK market share or market position. (Courtesy of BVG Associates Ltd. – 'WindSupply').

A brief overview of some of the major wind turbine manufacturers, with emphasis on those currently most relevant to UK projects, is given below. Many of the leading manufacturers are based (headquartered) in Europe (Denmark, Germany and Spain) and have production facilities and/or sales offices in other countries. However, top ten companies are also based in the US and India. Currently, there are no indigenous (UK based) wind turbine manufacturers and only one major manufacturer, Vestas, has any significant presence within the UK.

Vestas Wind Systems A/S (Denmark)

Vestas Wind Systems, headquartered in Randers, Denmark is the world leading wind turbine manufacturer with 28% of the world market. Vestas' core business comprises the development, manufacture, sale, marketing and maintenance of wind power systems that use wind energy to generate electricity and employs almost 14,000 people worldwide (see www.vestas.com). To the end of 2006 Vestas has installed capacity of approximately 25,000 MW and, as mentioned above, Vestas has installed approximately 40% of all current UK capacity.

Vestas has production facilities in Denmark, Germany, India, Italy, Scotland (towers), England (blades), Spain, Sweden, Norway, Australia and China. The UK based facilities will be described in more detail below. Turbines range in power from 850 kW to 3.0 MW.

Vestas strategy as regards procurement is focused on key supplier selection and to work with as few large, global suppliers as possible, whilst keeping sufficient capability and flexibility.

Siemens Wind Power A/S (Denmark)

Siemens Wind Power was created from the acquisition of Bonus Energy, the fifth largest turbine manufacturer in the world with annual sales of over \$350M, and currently employs more than 2,300 people (see www.siemens.com/powergeneration/windpower). Siemens Wind Power is headquartered in Brande, Denmark, the Bonus Energy headquarters. In total, Siemens has approximately 6,300 wind turbines installed worldwide with almost 5,500 MW of installed capacity.

Siemens Wind Power is one of the main suppliers to the UK wind industry and is expected to become prominent in the UK offshore market. Key relevant in-house manufacturing locations are at Brande (nacelles and hubs) and Aalborg (blades), both in Denmark. In 2005, Siemens also acquired Winergy (Germany), one of the gearbox suppliers to the industry. All components are brought in and assembled in-house (in Denmark). Turbines range in power from 1.3 to 3.6 MW.

GE Wind Energy (USA)

GE is one of the world's leading wind turbine suppliers, based in Atlanta, Georgia, USA, and with over 7,500 worldwide wind turbine installations, comprising more than 9,800 MW of installed capacity (see www.gepower.com).

GE Wind Energy's current product portfolio includes wind turbines with rated capacities ranging from 1.5 to 3.6 MW, and support services ranging from development assistance to operation and maintenance. With in-house manufacturing facilities in Salzbergen, Germany (nacelles & hubs), Noblejas, Spain (nacelles & hubs), and the USA, Canada and China, GE is a global provider of wind turbines and is pursuing opportunities in the UK.

REpower Systems AG (Germany)

REpower Systems AG, headquartered in Hamburg, Germany, has recently been acquired by India's Suzlon Energy for €1.2 billion. It is one of the leading manufacturers of onshore and offshore wind turbines, and develops, produces and sells wind turbines with outputs ranging from 1.5 to 5.0 MW. The company also provides a comprehensive service and maintenance range.

REpower has manufacturing sites in Husum (North Frisia) and Trampe (Brandenburg), and has approximately 830 employees worldwide. The company is represented in European markets such as

France, the UK, Italy, Portugal and Spain and in the international markets of Japan, China and Australia through its sales partners, subsidiaries and investments.

REpower UK, Ltd. is a joint venture with Peter Brotherhood. Ltd. (Edinburgh), which dates back to 2003. The company sells REpower Systems in the UK and provides a full after market sales service (see www.repower-uk.co.uk).

Nordex AG (Germany)

Nordex AG, headquartered in Norderstedt, near Hamburg, Germany, has over 3,000 turbines installed worldwide, with a total installed capacity of over 3,400 MW, and employs approximately 1,300 people. Turbines range in power from 1.3 to 2.5 MW (see www.nordex.de).

Nordex has been a developer and manufacturer of wind turbines, including rotor blades, since 1985. The company has offices and subsidiaries in 18 countries and is active in Europe, the US, India and China and has production facilities in Rostock, Germany (nacelles and blades) and in China (Nacelles and blades) in a market which will continue grow to in the course of the next few years.

Gamesa Eólica S.A. (Spain)

Gamesa, headquartered in Madrid, Spain is one of the world's largest wind turbine manufacturers. In 2006, it was ranked second worldwide in wind turbines supplied, with more than 10,000 MW installed. Gamesa has its own design and development capability for wind turbines and manufactures blades, root joints, blade moulds, gearboxes, generators, converters and towers, besides assembling the wind turbine in 29 manufacturing facilities (almost all in Spain). Turbines range in power from 850 KW to 2.0 MW (see www.gamesa.es).

Enercon GmbH (Germany)

Enercon, headquartered in Aurich, Germany, is Germany's leading manufacturer of wind turbines. Established in 1984, Enercon pioneered the development of the gearless wind turbine and large-scale manufacturing of the gearless systems began in 1993. Enercon has over 11,000 turbines installed in more than 30 countries worldwide, with a total installed capacity of over 12,000 MW (more than 60% of which is installed in Germany), and employs approximately 8,000 people, either directly or indirectly. Enercon turbines range in power from 330 kW to 2.0 MW. Enercon manufactures most of its own key components in-house (see www.enercon.de).

Enercon has manufacturing facilities in Germany (Aurich, Emden and Magdeburg), Sweden, Brazil, India and Turkey, with a further facility under construction in Portugal.

Suzlon Energy (India)

Suzlon Energy is Asia's largest fully integrated wind power company. It has a subsidiary in Germany for technology development, an R&D facility in the Netherlands for rotor blade design and tooling, and wind turbine and rotor blade manufacturing facilities in India. In 2006, Suzlon acquired Hansen Transmission (Belgium), which manufactures gearboxes. Suzlon turbines range in power from 350 KW to 2.0 MW (see www.suzlon.com).

Suzlon Energy has no turbines installed in the UK and its markets are India, China, USA, Australia and selected EU countries.

Clipper WindPower (USA)

Clipper WindPower was formed in 2001, employs 500+ people and is headquartered in Carpinteria, CA, with a wind turbine and manufacturing facility in Cedar Rapids, Iowa.

The company's 2.5 MW Liberty wind is variable speed with a unique, distributed powertrain, with four permanent magnet generators and advanced power electronics. It develops and builds wind power

generating projects in the Americas and Europe, but no Clipper WindPower turbines are currently installed in the UK (<http://www.clipperwind.com/>). However, as will be described below, the company has announced that it is to develop wind turbine generators in the UK at Blyth. Clipper WindPower have adopted a global, multiple-source supply chain with assembly close to markets.

4.3. Structure of the UK Wind Industry

Before describing in detail the components of a wind turbine and the component supply chains, an understanding of the structure of the wind industry is necessary. A good outline is given in a Scottish Enterprise document, 'Doing Business with the Wind Turbine Manufacturers: Becoming Part of Their Supply Chain', July 2006. This is summarised below in Figure 4.6.

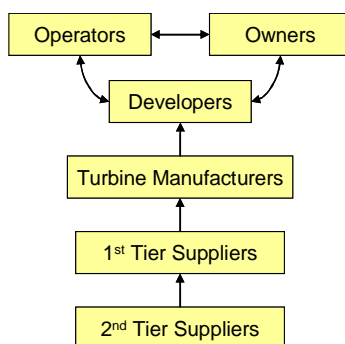

Figure 4.6 - Outline of the structure of the UK's wind power industry (based on information in the Scottish Enterprise document: 'Doing Business with the Wind Turbine Manufacturers: Becoming Part of Their Supply Chain', July 2006).

Wind farm owners are often utility companies, although smaller projects can be owned by private companies. The wind farm operators are responsible for the day-to-day operations and maintenance of the wind farm, and some specialist operating companies exist. It should be noted that some organisations may also be both owners and operators. Wind farm developers are primarily responsible for planning through construction, often to final completion. Developers may also offer operations and maintenance services.

The turbine manufacturers supply the wind turbines and, as mentioned above, the market is dominated by several large players. The largest manufacturers are based in countries where the wind industry has seen massive growth over the past twenty years or so, namely Germany, Denmark and Spain, although some large turbine manufacturers are now based in countries where wind industry growth is significant and more recent – eg, the US and India.

In general, the 1st tier suppliers offer products or services to turbine manufacturers or construction contractors, for example: generators, gearboxes, transformers, cabling, etc., and the 2nd tier suppliers provide component parts to 1st tier suppliers – eg, machined parts, fixings and electrical components.

4.4. Wind Turbine Technology

Wind turbines have increased in size from a maximum of approximately 50 kW in 1980 to 5 MW today, with even larger turbines under development. The expected increase in average turbine size is shown below in Table 4.5 below, which also shows the increased turbine size associated with offshore generation as compared with onshore generation.

		'08	'09	'10	'11	'12
Onshore	Average turbine size (MW)	2.0	2.1	2.2	2.3	2.4
Offshore	Average turbine size (MW)	3.4	3.6	3.8	4	4.2

Table 4.5 - Average turbine size to 2012 (information from BVG Associates Ltd.).

The key components which make up a wind turbine are described below (see also Figure 4.7). Most major components are common to all turbines, although design differences from manufacturer to manufacturer mean that there is some variation in specific components.

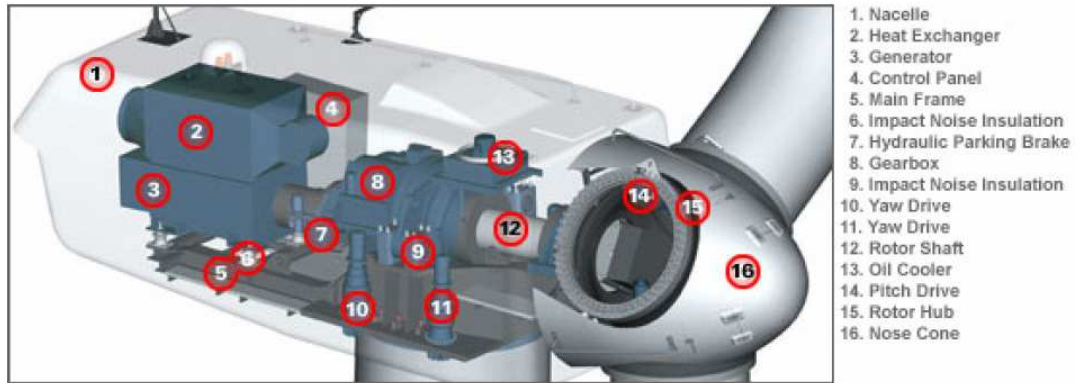

Figure 4.7 - Major components of a wind turbine (from the Scottish Enterprise document: 'Doing Business with the Wind Turbine Manufacturers: Becoming Part of Their Supply Chain', July 2006). (Courtesy of Scottish Enterprise: <http://www.scottish-enterprise.com/>).

Typical component weights and costs, as a percentage of total cost (for a 2 MW turbine) are given below in Figure 4.8. Clearly factors such as turbine size and tower height, onshore vs. offshore, etc. affect the relative weights and costs.

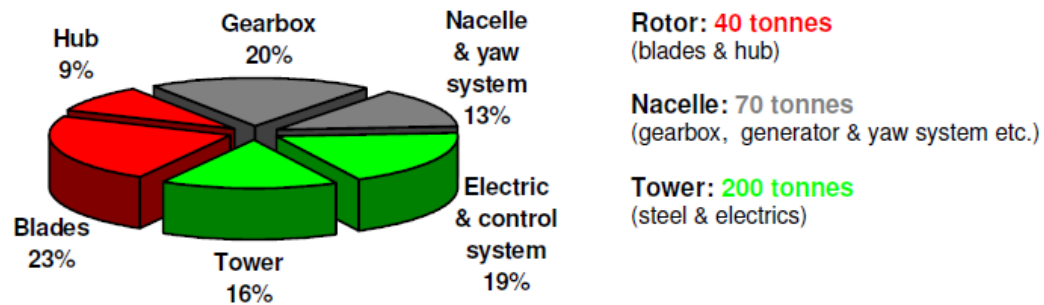

Figure 4.8 – Approximate weights and costs of wind turbine components. (Courtesy of BVG Associates Ltd.).

Suppliers of major components for the main wind turbine manufacturers are given in Table 4.6, below:

Major wind turbine manufacturers and their suppliers					
Turbine maker	Rotor blades	Gearboxes	Generators	Towers	Controllers
Vestas	Vestas, LM	Bosch Rexroth, Hansen, Winergy, Moventas	Weier, Elin, ABB, LeroySomer	Vestas, NEG,DMI	Cotas (Vestas), NEG (Dancontrol)
GE Energy	LM, Tecsis	Winergy, Bosch, Rexroth, Eickhoff, GE	Loher, GE	DMI, Omnical, SIAG	GE
Gamesa	Gamesa, LM	Echesa (Gamesa) , Winergy, Hansen	Indar (Gamesa) , Cantarey	Gamesa	Ingelectric (Gamesa)
Enercon	Enercon	Direct drive	Enercon	KGW, SAM	Enercon
Siemens Wind	Siemens, LM	Winergy	ABB	Roug, KGW	Siemens , KK Electronic
Suzlon	Suzlon	Hansen , Winergy	Suzlon , Siemens	Suzlon	Suzlon , Mita Teknik
REpower	LM	Winergy, Renk, Eickhoff	N/A	N/A	Mita Teknik, ReGuard
Nordex	Nordex	Winergy, Eickhoff, Maag	Loher	Nordex , Omnical	Nordex , Mita Teknik

Notes: Towers are often manufactured locally in the country of installation
Names in bold indicate in-house supply or ownership of supplier by turbine manufacturer.
REpower is now owned by Suzlon.

Table 4.6 – Supply of major components to the world’s largest wind turbine manufacturers (from ‘Supply Chain: The Race to Meet Demand’, in ‘Wind Directions’, Jan/Feb 2007, pp. 27-34).

4.4.1. The Nacelle

When applied to a wind turbine, the term nacelle does not describe an individual component, but instead it houses the main components within its fibreglass cover. However, the nacelle cover itself is made of glass fibre reinforced plastic (GRP). The yaw and pitch systems within the nacelle automatically rotate the nacelle so that the turbine rotor is facing directly into the wind, and adjust the angle of the blades, respectively. The major components, within and external to the nacelle, are described in more detail below, but additional components within the nacelle include:

- Nacelle bed plate – large cast part on which major components sit.
- Main bearing (in most cases) – has to withstand varying loads generated by the wind.
- Main shaft (in most cases) – transfers rotational force of the rotor to the gearbox.
- Brake system – disc brakes to stop the rotor when needed.
- Yaw system (sensors, motors, gearboxes, pinions) – rotates the nacelle to face the wind.
- Control and power panels (power converter)
- Sensors, cabling
- Cooling systems
- Maintenance equipment

4.4.2. Rotor Blades

Large, modern wind turbines are three-bladed designs and most rotor blades are made of glass fibre reinforced plastic (GRP), which are usually based on either polyester or epoxy resins. New materials such as carbon fibre or aramid (Kevlar) are also being introduced as reinforcing materials, which is enabling larger blade sizes. In addition, more traditional and natural materials such as birch and balsa woods are also used as blade reinforcing materials, although their application is currently not widespread.

The rated power of the turbine varies with the square of the length of the blades; hence, the drive to larger and larger turbines. A typical 2 MW turbine would have blades of approximately 40m in length, whilst the blade length for a 5 MW turbines is a little over 60 metres, and weighs 18 tons (the LM 61.5 P).

The rotor blades for wind turbines are manufactured on a global basis and most wind turbine manufacturers now have blade manufacturing facilities close to final turbine assembly points. This globalisation is largely due to the fact that blades are large and, therefore, difficult and expensive to

transport, although factors such as minimum local content may also apply, as is the case in China, where a local content of at least 70% is demanded.

Wind turbine manufacturers have three main strategies for sourcing rotor blades, which are: (1) to design and manufacture in-house, (2) to design in-house and then out-source blade manufacture, and (3) to cooperate with a third party in the blade design and development and then outsource the manufacture to the development partner.

There is a clear tendency to manufacture in-house (see Table 4.7) to protect intellectual property and to secure the supply chain. However, the world's largest blade manufacturer is the Danish company LM Glasfiber, which is not a turbine manufacturer, and which has eight manufacturing facilities around the world (with more announced) and has approximately 27% of the global market.

	Vestas	GE	Enercon	Gamesa	Suzlon	Siemens
In-house	●		●	●	●	●
LM (DK)	○	●		◎	○	
Tecsis (Brazil)		◎				
MFG (US)		○				
Abeking and Rasmussen (GE)			○			
Euros (GE)						

● Main supplier; ◎ Supplier; ○ Small Supplier

Table 4.7 - Blade suppliers for the major turbine manufacturers. (Courtesy of BTM Consult ApS).

Recently, there have been some issues associated with the supply of rotor blades, with demand outstripping installed capacity and through a shortage in carbon fibre necessary for the larger blades, in particular. However, with a number of new blade factories being planned around the world and an increase in global carbon fibre capacity, the supply of rotor blades should not be an issue in the coming years.

4.4.3. Rotor Hubs and Other Large Castings

The rotor hub is typically made from SGI (Spherical Graphite cast Iron) and weighs approximately 6-10 tonnes (with dimensions of approximately a 2.5 metre cube) for a 2 MW wind turbine (see Figure 4.9). The rotor blades are bolted to the hub, which is generally attached to a low speed shaft which connects to the turbine's gearbox. The rotor and hub assembly typically rotates at 10-25 rpm, with a 'cut-in' wind speed of 3-4 metres per second and a cut-out speed of 25 metres per second.



Figure 4.9 – A wind turbine rotor hub. (Courtesy of 'WindSupply': <http://www.windsupply.co.uk/>).

The high demand for these large castings and SGI castings of a similar size for the nacelle bedplate (Figure 4.10), which secures the drive train, has created some supply chain issues, for the larger turbines in particular.



Figure 4.10 – A wind turbine nacelle bedplate casting.
(Courtesy of 'WindSupply': <http://www.windsupply.co.uk/>).

4.4.4. Gearboxes

Power from the rotation of the wind turbine rotor is transferred to the generator through the power train, usually consisting of a main shaft, gearbox and high-speed shaft. A gearbox converts the slowly rotating, high torque power from the wind turbine rotor into high speed, low torque power, which is used for the generator. Gearboxes for the wind industry have been supplied for many years by a relatively small list of manufacturers (Table 4.8).

	Vestas	GE	Gamesa	Suzlon	Siemens	REpower
In-house		○				
Winergy	⊙	⊙	⊙	●	●	⊙
Hansen	⊙		⊙	○		
Moventas	●	●	●			
Bosch Rexroth	⊙	●	●			
Eickhoff		●				●
Echesa;			⊙			
Renk						⊙
Jahnel-Kestermann	○					

● Over 80%; ⊙ 60 to 20%; ● 30 to 10%; ○ Less than 10%

Note 1: This table is subject to the reservation that suppliers change regularly.

Note 2: The size of delivery is a very rough estimate.

Note 3: Winergy is owned by Siemens Power and Hansen is now owned by Suzlon.

Note 4: Winergy, Bosch, Eickhoff, Renk and Jahnel-Kestermann (all Germany), Hansen (Belgium), Moventas (Finland), Echesa (Spain).

Table 4.8 - Gearbox suppliers to the major wind turbine manufacturers.
(Courtesy of BTM Consult ApS)

There is only one major wind turbine supplier in the world, the German Enercon, which avoids a gearbox by using a direct drive concept. Thus, 90% of the market demands gearboxes, and as such gearboxes are currently identified as representing a supply chain shortage, which may be linked to a shortage of gearbox production facilities, a shortage of large bearings (lead times of up to one year) and problems with gearbox design. The latter has also resulted in a relatively high number of reported generator failures.

4.4.5. Generators

The generator converts the rotational, mechanical energy into electricity. The market for generators is characterised by a number of very large companies making generators for the industry as a small part of their overall business in electrical machinery (see Table 4.9). The standard arrangement today uses doubly-fed induction generators, though permanent magnet and synchronous generators are also used.

There are currently no signs of a shortage in generator supply. Major 1st tier suppliers include: ABB (the market leader), Siemens (Germany) Converteam (France, ex-Alstom Power Conversion), Elin EBG Motoren (Germany), Hitachi (Japan), Leroy Somer (France), Loher (Germany), VEM (Germany), and Winergy (Germany). In addition, a number of turbine manufacturers make generators in-house (eg. Enercon, Gamesa, and Vestas).

	Vestas	GE	Enercon	Gamesa	Suzlon	Siemens
In-house	○ ¹		●			
ABB	⊙					⊙
Siemens					⊙	⊙
Indar				⊙		
Elin	⊙				●	
VEM		⊙				
Winergy (Loher)		⊙			⊙	
Cantarey Reinosa				⊙		
Leroy Somer	○					

● Main supplier; ⊙ Supplier; ○ Small Supplier

Note 1: This is production from the former Weier which Vestas acquired in 2005

Table 4.9 - Generator suppliers to the major turbine manufacturers. (Courtesy of BTM Consult ApS).

4.4.6. Towers and Foundations

The tower of the wind turbine carries the nacelle and rotor. Most large wind turbines use tubular steel towers, although steel lattice and concrete towers are also used. The tubular steel towers are manufactured in roll-formed and welded sections of anywhere between 10 and 30 metres in length, with flanges at the ends, and are bolted together on the site. Tower heights and selection of tower construction materials are dependent upon factors such as cost, the rotor diameter and site wind speed conditions, and range from 50 metres for a 1 MW turbine to as high as 125 metres for the largest turbines (> 3 MW onshore), and steel towers can weigh up to 250 tonnes.

The towers are conical - with their diameter and wall thickness increasing towards the base, to increase their strength and save materials. Some of the turbine manufacturers have in house manufacture of towers, including Vestas (see below) and Enercon. The cost of a tower for a wind turbine is approximately 20% (with a likely range of 16-25%) of the total investment.

Typically, the wind turbine manufacturers will look to source towers locally with respect to individual installation sites (eg, wind farms) or significant markets (countries). This is related to relatively high transportation costs and the fact that the technology is relatively mature and technology transfer is relatively easy, although the quality standards demanded by the turbine manufactures are high.

Most European tower manufacturers are currently working at the limit of their capacities, but there are possibilities for finding local sources in other world markets and towers are not likely to create supply problems.

4.5. UK Wind Turbine Component Supply Chain

4.5.1. Introduction

With the rapid growth in the wind power industry, some supply chain issues have arisen in major components (eg, blades, gearboxes and bearings). Some turbine manufacturers have sought to address these issues by producing more and more components in-house and some vertical integration has occurred, with turbine manufacturers acquiring major component manufacturers. This may have a significant impact on the ability of UK based companies to enter certain parts of the wind power supply chain, as described below.

As a result of the rapid growth in wind power installations in the UK, and the current supply chain limitations, the turbine manufacturers are also looking to the UK supply chain to satisfy demand and provide some flexibility in sourcing. However, competition is fierce and the wind industry is a global industry, with global supply chains, and price, quality and delivery are all important. In particular, for UK based developments there are very strong, existing European supply chains and UK based companies have little or no track record in supplying to the wind industry.

According to 'Wind Supply', the demand for wind power dramatically exceeds the ability of the marketplace to supply and every major wind turbine supplier has some significant problems associated with securing their supply chain. As a consequence, lead times for delivery of wind turbines are as long as two to two and a half years.

Currently, the UK has a very limited share of wind turbine & wind turbine component manufacturing and market leader Vestas are the only manufacturer to have production facilities within the UK, with a tower manufacturing facility in Cambeltown, Scotland and blade design and manufacturing on the South Coast (Isle of Wight and Southampton). Thus, with turbines accounting for up to 50% of wind turbine project costs, it is important that UK companies are involved in supply of components to the turbine manufacturers.

Analysis of the supply chain for the E.ON UK plc 60 MW wind farm at Scroby Sands, off Caister-on-Sea, Norfolk (see 'Scroby Sands Supply Chain Analysis', A Report to Renewables East by Douglas-Westwood Limited and ODE Ltd., Commissioned by the DTI, DWL Report Number 334-04, July 2005) concluded that the existing supply chain within the UK has the capability to support the majority of activity inherent within the development, construction and operation of an offshore wind farm. However, the report also concluded that the supporting supply chain for offshore wind farm projects would continue to evolve and would not fully emerge until the market develops further. The same is also true, but to a lesser extent, of ongoing onshore developments.

The focus of the UK's supply chain for wind power projects, onshore and offshore, has been on the projects development and service phases, with much less emphasis on the manufacture and supply of wind turbine (and tower) components. This may be related to a number of factors, which include:

- the risks associated with developing a capability for what, to date, has been intermittent and relatively low volume demand – eg, for towers and large castings.
- the costs associated with product/component development activities.
- the procurement policies of the turbine manufacturers themselves (ie, either in-house or restricted supply sourcing, or very low margin opportunities) – eg, for blades & large castings.

For example, for the Scroby Sands wind farm, although contracts to the value of £38.8M (48%) were awarded from a total expenditure of approximately £80M, the highest levels of UK content were attained within the development and operation phases. The primary area in which the UK was shown to lack capability was within activities related to the manufacture and installation of blades and nacelles (£3M of a total spend within the construction phase of £28.6M). Thus, the Scroby Sands project illustrates well the supply and value chain gaps which exist within the UK. In fact, the 48% UK based 'contribution' to this project would likely be lower today, as may be the case for ongoing offshore projects, as some parts of the Scroby Sands supply chain have since been lost.

It is clear that unless UK based companies show a commitment to excellence, for what is a highly demanding and (cost) competitive industry, they will not make significant inroads into the component and manufacturing supply chain(s).

In the following sections, examples will be given below of the UK based companies involved in the wind turbine supply chain and opportunities for UK involvement will be highlighted on a component by component basis. However, before doing so, some recent activity aimed at establishing wind turbine manufacture itself within the UK will be described.

4.5.2. Wind Turbine Manufacture in the UK

In early October 2007, it was announced that the US wind turbine manufacturer 'Clipper Windpower' is to develop a new generation of offshore wind turbines at Blyth in the North East of England, supported by One NorthEast (£5M investment), with NaREC providing engineering, testing and development services in support of the project. Clipper Windpower will use NaREC's blade test and manufacturing facilities to engineer, construct and test a prototype 7.5 MW offshore turbine (the Britannia turbine), which will be the largest offshore in the world. Engineering development of the new turbine will be shared between Clipper's Advanced Technology Group, based in Carpinteria, California, and Clipper WindPower Marine to be based in Blyth.

In addition, Able UK Ltd. (Hartlepool, Co. Durham), a ship recycling and demolition / reclamation company, has been approved planning for the development and expansion of its Teesside Environmental and Recycling Centre (TERRC) facility at Seaton Port, Hartlepool. The application includes the construction of three new quays, with deep water access, a dry dock and a proposal for facilities for the manufacture of wind turbine towers and blades, as well as the assembly of wind turbine generator units.

4.5.3. Rotor Blades

As mentioned above (Section 4.4.2.), most major turbine manufacturers produce blades in-house, the exception being that of the major blade supplier LM Glasfiber, which supplies several of the large turbine manufacturers. However, as also mentioned above, there are UK blade manufacturing facilities owned by Vestas (see below).

Vestas Blades UK (Isle of Wight and Southampton)

The main activity of Vestas Blades, Isle of Wight (Vestas Blades UK) is the production of 40 metre turbine blades (Figure 4.11). Each blade comprises a web which is glued between two blade shell sections. The main components of the blades are wood (birch and balsa), carbon fibre and fibreglass infused with epoxy resin. After joining the two blade halves, the blade is finished and painted. All fabrication is carried out in-house. It should be noted that although Vestas use birch and balsa in blade manufacture, this is not thought to be common amongst other manufacturers.

Vestas Blades UK consists of four sites, two on the Isle of Wight and two in Southampton. The largest site, in St. Cross, Newport (Isle of Wight), manufactures the 40 metre blades. The site at Venture Quays, Cowes (Isle of Wight) concentrates on the production of prototype blades, whilst the third site in Southampton manufactures the webs and the painting of blades. A company owned barge is used to carry materials between the sites and to transport finished blades to the fourth site at Southampton Port, for global shipments. It is believed that the blades produced at Vestas' Isle of Wight facilities are exported and are not used in UK based projects.

Vestas Blades (previously NEG Micon) has been based at the St Cross Business Park in Newport since October 2001, and in 2004, new production lines and an international training facility were established on the Cowes Waterfront. Funding for both facilities was provided by the Regional Development Agency SEEDA (South East England Development Agency), and the combined facilities employ 570 people.



Figure 4.11 - Wind rotor blade fabrication at the Vestas Isle of Wight site.

From: 'Environmental Statement 2006 – Company Site. Vestas Blades, Isle of Wight, England'.
(Courtesy of Vestas: <http://www.vestas.com>).

Vestas has global, strategic supply agreements in place which cover most of the materials used by Vestas Blades UK. Information regarding materials supply was provided by Vestas, and some of their suppliers, as follows:

- The birchwood comes from sustainable sources in Russia and Finland, and the balsa from Ecuador.
- Epoxy resins and hardeners are currently formulated in the UK by Gurit UK Ltd. (ex-SP Systems, Ltd., Newport, Isle of Wight), but the raw materials are not sourced within the UK.
- Glass fibre used to be supplied from the UK, but the supplier has recently moved production elsewhere.
- Cast iron and aluminium are also used for brackets and fixings.
- Pulltruded carbon fibre stiffening ribs, 28m and 22m in length, for blade leading edges are supplied from Fibreforce Composites, Ltd. (Runcorn, Cheshire), a fully owned subsidiary of the Finnish Exel Oyj Group.
- Moulds for blade manufacture, are supplied by Solent Composite Systems, Ltd. (Cowes, Isle of Wight).

Vestas added that there is some scope for individual operations to source locally any materials which meet specifications. However, currently many materials used (wood and composites) are not produced in the UK to the scale demanded by their operations.

Currently, Vestas Blades have no materials supply issues, although there are some concerns regarding securing supply of some of the materials required, which is linked to the industry growth rate. Vestas are currently the world's biggest user of carbon fibre, and in the top 10 global users of (epoxy) resin.

Summary information on raw materials and consumables used at the Isle of Wight site(s) is given in Figure 4.12 below, which is taken from a document which can be found on the Vestas website: <http://www.vestas.com>, 'Environmental Statement 2006 – Company Site. Vestas Blades, Isle of Wight, England').

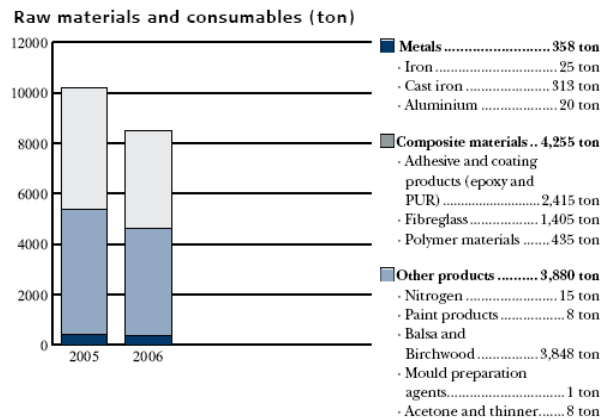

Figure 4.12 - Raw materials and consumables used at the Vestas, Newport, Isle of Wight site. From: 'Environmental Statement 2006 – Company Site. Vestas Blades, Isle of Wight, England'. (Courtesy of Vestas: <http://www.vestas.com>).

It is of interest to compare equivalent raw materials use information from larger manufacturing facility, in this case, the company's main blade manufacturing facility in Denmark (see Figure 4.13 below), which has approximately three times the raw materials consumption of the Isle of Wight site. However, it should be noted that the manufacturing techniques at the two facilities are different and the Lem site also carries out blade repairs; thus, direct comparisons of materials consumption cannot be made.

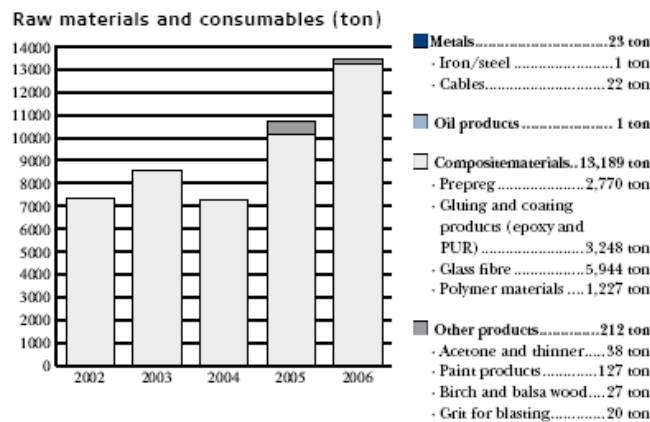

Figure 4.13 – Raw materials and consumables used at the Vestas Lem site in Denmark. From: 'Environmental Statement 2006 – Company Site. Vestas Blades, Lem, Denmark'. (Courtesy of Vestas: <http://www.vestas.com>).

As mentioned above, Gurit UK (ex-SP Systems Ltd., Newport, Isle of Wight) supply materials for wind turbine rotor blade manufacture. The facility is also home to Gurit's R&D Centre and employs approximately 400 people. Gurit is the world's largest supplier of materials for blade manufacture and also has manufacturing facilities in Magog (Canada), Albacete (Spain) and Kassel (Germany).

In addition to those suppliers mentioned above, the following UK based companies, with capability in the supply of GRP and carbon fibre products used in the manufacture of rotor blades, and listed in the 'Envirolink Northwest Supply Chain Directory 2007', were contacted: Formax UK Ltd. (Narborough, Leics.), Production Glassfibre Ltd. (Kirkcaldy (Fife), Accrington (Lancs.), Wilstead, (Bedfordshire), Fothergill Engineered Fabrics Ltd. (Rochdale, Lancs.), Brookhouse Composites Ltd. (Darwen, Lancs.) and Harviglass GRP Ltd. (Hyde, Cheshire).

From the responses of these companies, all of which are believed to be capable as regards supply into wind turbine rotor blade manufacture, the common themes appear to be that they have either supplied, and are no longer doing so, or have never supplied into the market, because of low margins/prices, and the buoyancy of other markets – specifically the aerospace sector.

In the recent past, issues with the supply of carbon fibre, linked to the high demand from the wind and aerospace industries, in particular, has caused blade delivery delays. However, this problem is now being addressed by carbon fibre manufacturers (not UK based) with the installation of additional (and capital intensive) capacity.

The concerns regarding supply of carbon fibre also prompted Vestas to sign a long-term strategic deal with the carbon fibre producer Zoltek (St. Louis, MO, USA, with a carbon fibre facility in Hungary), to supply carbon fibres for wind turbine blades.

4.5.4. Rotor Hubs and Other Large Castings

Large SGI castings of between 6-10 tonnes are required for rotor hubs and nacelle bed plates, and as mentioned above, there are some supply chain issues, for the larger turbines in particular. The supply of such castings to the wind industry from UK suppliers is minimal; a consequence of intermittent demand and low margins; the latter expressed by Coupe Foundry, Ltd., Preston, Lancs. and others). In addition, the wind turbine manufacturers have sought local sourcing - ie, local to the nacelle assembly facilities and, therefore, typically within mainland Europe. For example, Vestas has its own 'Windcast' foundries.

Clearly, there are a number of UK foundries who are capable of producing these castings, although the quality and service of UK suppliers has been questioned. However, if the requirements of service, quality and price can be met, and with relatively high transportation costs, it would appear to make sense for the turbine manufacturers to source local to installations for such high mass components.

In addition to the demand for these large hub and bedplate castings, recent developments in direct drive turbines using permanent magnet (Fe-Nd-B) and induction generators will lead to a new demand for very large castings for generator housings. Further details on these developments by 'Converteam' (ex-Alstom Power Conversion), a leader in the field of power conversion (high voltage motors, drives, automation and process control, etc.) will be given below.

'Converteam' estimate that in 2008, they will need two SGI castings per week, with dimensions 4.7 metres diameter by 3.5 metres long, and requiring a 25 tonne pour, in addition to castings for the rotor and bedplate. This demand is anticipated to rise to the equivalent of 4.5 castings per day by 2011, again in addition to the rotor and bedplate castings.

'Converteam' have also stressed that in the same way as many other components for the wind industry are sourced on a global basis, time is short and the UK is not their only option. They are looking for multiple suppliers and are working with BERR to assist with investment opportunities.

4.5.5. Gearboxes and Generators

Entry into the supply chain for gearboxes and gearbox components is considered to be extremely difficult. The industry has experienced very long lead times for some of the major gearbox components (in particular), the bearings, and as a result, some of the turbine manufacturers have brought gearbox manufacture in-house through acquisitions.

As mentioned above, 'Converteam' have developed direct drive permanent magnet and induction generators (so-called second generation generators), which will reduce the number of parts required in a wind turbine and will eliminate the need for gearboxes, in particular; gearbox failure being one of the most significant causes of turbine failure. 'Converteam' employs 3,800 people worldwide and has operations in 16 countries, including a major manufacturing facility and the company's development centre, in Rugby.

Converteam' is also developing 'third generation', high temperature super-conducting direct drive generators with support from BERR, which will lead to reduced generator unit sizes and be capable of pushing the power output to 10 MW in a direct drive turbine.

4.5.6. Towers and Foundations

The existing tower manufacturing capability within the UK is relatively small scale, under-invested and mainly located on the West Coast – ie, not well placed for east coast offshore. Also, UK tower manufacturers have suffered from intermittent demand from the UK wind market.

According to BVG Associates Ltd., and based upon the number of wind farms both consented and in planning, between two and four thousand wind turbine towers are required in the UK over the next five years; for both offshore (mainly East Coast) and onshore wind farms (see Table 4.10 below).

Location	2008	2009	2010	2011	2012	Total
Offshore – East Coast	60 - 70	55 - 60	70 - 145	40 -185	20 -140	245 - 600
Offshore – West Coast	0 - 5	10 - 30	10 - 60	5 - 95	10 - 65	35 - 255
Onshore	350-420	430-680	410-600	390-610	330-580	1910-2890
Total	410-495	495-770	490-805	435-890	360-785	2190-3745

Table 4.10 - Estimate of the number of wind turbine towers required in the UK.
(Courtesy of BVG Associates Ltd.).

At approximately 200 tonnes per tower, the low estimate gives approximately half a million tons of steel for the towers alone. The foundations, steel monopiles, transition pieces, etc. will likely double this requirement. However, towers are regarded as being a commodity component, and technology transfer perhaps easier than for most other turbine components. In addition, as mentioned above, tower transport costs to the UK can be high – as high as £20k for transportation to the UK from mainland Europe. Thus, the turbine manufacturers are looking to source locally, and the following information from the leading manufacturers is taken from a presentation given at a 'WindSupply' Steel Tower Forum, held in May 2007:

Siemens - has previously purchased towers in UK, and is again interested in discussions regarding manufacture within the UK, once suppliers have demonstrated capability.

Vestas – as mentioned above, currently has its own tower facility in Campbeltown, Scotland, although 50% of the UK sourced towers are manufactured in mainland Europe.

Nordex – has previously purchased towers in UK and have recently requested expressions of interest from UK suppliers, and has made it clear that towers are the major requirement as regards UK sourcing.

REpower – has advised that towers are the major requirement as regards UK sourcing. The company has purchased 5MW offshore towers from UK, but all other towers are imported

Enercon – currently imports all towers and has not expressed any interest in sourcing within the UK. Enercon makes some towers both internally and using a dedicated sub-contractor.

Gamesa – currently imports all towers, but has expressed an interest in sourcing towers in the UK. Gamesa make some towers using a dedicated sub-contractor.

GE Wind Energy - currently imports towers, but has expressed interest in sourcing towers in the UK.

Currently, one turbine manufacturer, Vestas, has a tower facility in the UK and Camcal Ltd. manufacture towers at its facility in Stornoway (see below). Also, Isleburn Mackay and McLeod Ltd. (Evanton, Ross-shire, Scotland) have manufactured both monopiles and towers for offshore wind farms.

In addition, there are a number of UK based companies active in seeking opportunities within the wind tower and foundation supply chain – for example Able UK, Ltd (Billingham, Teesside) and Sheffield Forgemasters, Ltd., the latter being at the development stage of a novel A-frame and mono-pile steel sub-structure for offshore wind turbines.

UK based companies may also look to supply tower internal components, such as ladders, platforms, electrical fittings, etc., which currently use components imported from the continent for towers installed in the UK.

Vestas Towers, Campbeltown (Scotland)

The core business of the Vestas' facility in Campbeltown, Scotland is to fabricate towers and foundations for wind turbines from steel plates (up to Grade 355 strength level), by rolling and welding into tower sections. Each tower section is surface-treated on-site using shot blasting, metallising and painting processes and is eventually fitted with tower internals prior to final inspection (Figure 4.14). If the turbines are for onshore applications, the foundations, which constitute a relatively simple steel 'can' (tube), which is then filled with concrete, are also produced at the Campbeltown facility.

Until the end of 2006, the site was also home to a nacelle assembly facility, with all components being imported from Denmark, but operations were discontinued in December 2006, and production of nacelles was moved back to Denmark, as it was not deemed to be cost effective to produce them in the UK.

The £9.5M purpose-built facility is leased from Argyll and the Isles Enterprise and Vestas also invested £2.8M in production machinery. The facility became operational in 2002 and now employs 125 people. Vestas were encouraged to locate in Campbeltown by the facility leasing arrangement brokered with the Local Enterprise Company and by a commitment by Scottish Power plc to further expand their already large portfolio of wind farms in the Kintyre area and elsewhere in Scotland.



Figure 4.14 – Tower fabrication at the Vestas Campbeltown site.

From: 'Environmental Statement 2006 – Company Site. Vestas Towers and Nacelles, Campbeltown, Scotland'. (Courtesy of Vestas: <http://www.vestas.com>).

Amongst the key projects supported by the Campbeltown facility have been the two 30 wind turbine, 60MW contracts for the North Hoyle Offshore Wind Farm (Rhyll), and the Scroby Sands offshore wind farm, a project that was worth €100M.

Currently, the facility manufactures between 8 and 10 tower sections per week, with each section weighing around 40 tonnes, and each tower being made up of 2-4 sections (ie, up to 160 tonnes). The site supplies 100-170 towers per annum for Vestas projects in the UK and overseas.

Historically, steel has been sourced from Spain, Poland, Denmark and the UK, although because of recent lead-time issues with supply from Spain, Vestas are now concentrating on supply from the Corus Plate Processing Centre at Bellshill, Lanarkshire and from Brown McFarlane Ltd., Stoke.

However, a tender process is used for each contract and if suppliers can meet all requirements they will be considered for future contracts.

Each tower section is surface-treated by using shot blasting, metallising and painting processes and eventually fitted with tower internals prior to final inspection. Additional information regarding materials supply was provided by Vestas, as follows:

- Hempel (Denmark) are the sole supplier of coatings / paints to Vestas wind turbines.
- Welding wire and rod is sourced locally; SAW welding consumables are sourced from Oerlikon.

All brackets and sub-assemblies for the internals of the towers are shipped in from Denmark, and Campbeltown simply orders parts based on the number of towers they have to build. As such there is currently no opportunity for local suppliers.

Summary information on raw materials and consumables used at the Campbeltown site is given in Figure 4.15 below, which is taken from a document which can be found on the Vestas website: <http://www.vestas.com>, 'Environmental Statement 2006 – Company Site. Vestas Towers and Nacelles, Campbeltown, Scotland'.

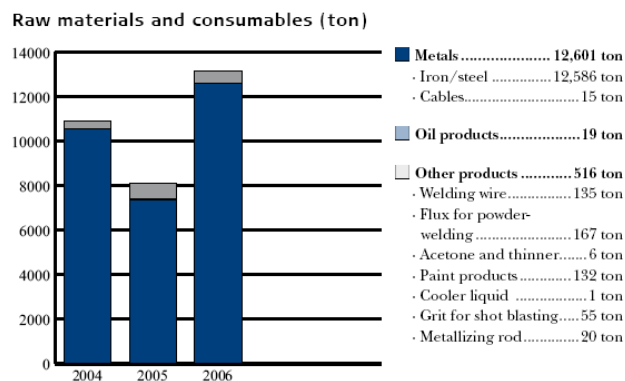

Figure 4.15 - Raw materials and consumables used at the Vestas Campbeltown site. From: 'Environmental Statement 2006 - Company Site. Vestas Towers and Nacelles, Campbeltown, Scotland'. (Courtesy of Vestas: <http://www.vestas.com>).

As in the case of Vestas' blade manufacture, it is of interest to compare the equivalent raw materials information from the company's main tower production facility in Denmark (see Figure 4.16 below), which has approximately four times the output, in tons, of the Campbeltown site.

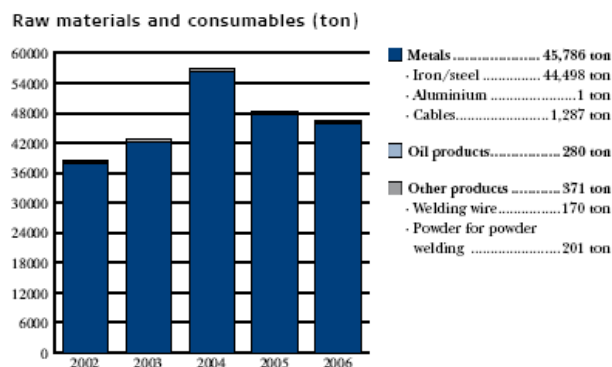

Figure 4.16 - Raw materials and consumables used at the Vestas Varde site in Denmark. From: 'Environmental Statement 2006 – Company Site. Vestas Towers, Varde, Denmark'. (Courtesy of Vestas: <http://www.vestas.com>).

Despite the clearly identified wish of the turbine manufacturers to source within the UK for UK based projects, some of the manufacturers see UK companies as being more risk-averse than their current suppliers and in many instances require some investment to be made as the latest manufacturing technologies are not being used. In addition, quality has been questioned.

The UK has a long tradition of supplying structures and service to the offshore sector, and so for the offshore market, in particular, would appear to be more than capable of supplying to the wind industry. However, because of the intermittent demand, UK based companies want to see long-term commitment & growth potential – ie, they want to see how the business can be profitable.

Camcal Ltd. (Stornoway, Isle of Lewis)

Camcal, Ltd. is perhaps the best known of the UK based wind tower manufacturers and its brief history can, to some extent, be used to illustrate the difficulties experienced by wind industry supply chain companies, to date.

Camcal Ltd. (ex Cambrian Engineering Ltd., which leased the facility before going into Administration in Feb 2004) is a Scottish company formed in 2004 to fabricate structures for the renewables industry. It had manufacturing plants at Arnish Point, Stornoway, Isle of Lewis and Bangor, Gwynedd, although the latter closed in August 2005 with loss of 60 jobs. It and its predecessor company have considerable experience in manufacturing towers and foundation structures for the onshore and offshore wind turbine markets, both in the UK and abroad.

Camcal agreed terms with Highlands and Island Enterprise (£3.4M investment), the Western Isles Enterprise (£700k investment), together with private finance of £ 5.5M, to re-establish a manufacturing operation for the renewable energy industry, with the creation of up to 100 jobs. However, the company shed 50 of 80 jobs in July 2006 and went into administration in August 2006, a result of insufficient work.

Altissimo Ltd (t/a Camcal) was established in January 2007 and the facility was reopened in March 2007, with up to 100 employees. The parent company, Altissimo, is an investment group.

Today, Camcal focuses on making tubular structures and will service other fabricators that require tubulars, usually 1200mm in diameter and larger, or work directly with clients. Camcal will also produce complete structures which require a large tubular or rolled shape content. Work such as wind turbine towers, tubular piles, etc. and structures that are large in weight and size are also well suited to the facility due to its export facility- the facility has open quayside access that connects directly to the open sea.

Rolling and shaping plates is Camcal's core business and the facility is designed to process up to 1,000 tonnes of steel per week. Steel plate (grade S355) up to 100mm in thickness and plate widths up to 4.0m can be rolled, and tubes of up to 7.0m diameter can be rolled and single tube lengths of up to 100m in length can be accommodated in the facilities' main hall.

4.5.7. Marinisation of Offshore Wind Structures

To reduce maintenance and extend operating life, it is essential that offshore wind turbine structures are protected against the harsh marine (salt spray) environment. As mentioned above, Hempel (Denmark) supply coatings to Vestas Towers in Scotland, and Hempel are the #1 supplier of coatings for wind turbines, supplying almost all major turbine manufacturers. However, there are a number of other companies with the capability to supply to the wind industry, including Leighs Paints (Bolton) and International Paints (Darwen, Blackburn).

4.6. UK R&D Activity in Wind Power Materials

As part of the EPSRC's SUPERGEN project, there is a 'Wind Energy Technologies Consortium' (which includes activities based on 'Structural Loads and Materials'), which focuses on improving the life of components.

An extensive list of wind energy R&D activities can be searched at the UK Energy Research Centre (UKERC) Research Atlas (specifically the Research Register) (<http://ukerc.rl.ac.uk/ERA001.html>).

The New and Renewable Energy Centre (NaREC), established in 2002 by the Regional Development Agency (RDA) One Northeast, as a Centre for Excellence for new and renewable energy technologies, and based in Blyth, Northumberland, has a (full) rotor blade testing capability. As mentioned above in Section 5.1, the US wind turbine manufacturer 'Clipper WindPower' is to develop a prototype 7.5 MW offshore turbine, with NaREC providing engineering, testing and development services in support of the project.

As regards materials related activities:

- QinetiQ, BAE Systems Ltd. and Vestas continue to work on breakthrough radar absorbing materials technology, applicable to turbine blade materials, and which should see considerable exploitation on a global scale. These activities are supported by the Technology Strategy Board (TSB) Collaborative R&D Programme.
- A relatively new programme has been initiated at NPL entitled: 'Enabling the next generation of structural health monitoring' (application to wind turbines).
- Various activities are ongoing at the Advanced Composites Manufacturing Centre (ACMC) at the University of Plymouth (Dr. Stephen Grove), which are related to rotor blade materials as follows:
 - Manufacture and Performance of Wind Turbine Blades. (EPSRC CASE Award with Vestas Blades (2006-2009)).
 - Production of Off-Axis Thermoplastic Composite Pre-preg. (Technology Strategy Board Collaborative R&D Programme (2005-2007)), partners: IMT, QinetiQ, Pultrex, EPM Technology, St-Gobain Vetrotex.
 - Moisture Transport and Absorption. (Vestas Blades, ongoing).
- The University of Southampton is also engaged in activities with Gurit, UK.
- Other materials based Technology Strategy Board supported activities include:
 - Corus: 'Cost Reduction and Life Extension of Offshore Wind Farms' (CORLEX).
 - Garrad Hassan & Partners: 'Finite Element Modelling of Offshore Wind Turbine Support Structures'.

4.7. Summary

The following gives a summary of the status of the UK's wind power industry, with particular emphasis on materials and manufacturing:

- Wind power is currently supplying approximately 1.5% of the electricity generated in the UK, with approximately 2,200 MW of installed capacity as of August 2007, with almost one third of this capacity being installed in 2006.
- However, the pace at which wind generating capacity is being installed is increasing rapidly, and there is currently 1,400 MW of new capacity under construction, 557 MW of which is offshore.
- The UK has the best offshore wind resources in the world and offshore wind power development is now a key part of UK's renewable policy.
- In the UK, wind energy is the fastest growing energy sector and over 4,000 jobs are sustained by companies working in the sector and Round 2 of offshore wind developments alone could create an additional 20,000 UK jobs.

- Competition within wind industry, particularly in Europe, is fierce and the wind industry is a global industry, with global supply chains, and price, quality and delivery are key.
- There are no indigenous UK based wind turbine manufacturers, although one of the World's leading manufacturers has manufacturing facilities in the UK and another has a sales and development joint venture to with a UK based energy sector supplier.
- Currently, the UK has a very limited share of the wind turbine & wind turbine component manufacturing market and with turbines accounting for up to 50% of wind turbine project costs, it is important that UK companies are involved in supply of components to the turbine manufacturers.
- However, here are significant gaps in the UK supply chain for wind turbine manufacture and wind turbine components.
- With rapid growth in the wind power industry, some supply chain issues have arisen in major components (eg, blades, gearboxes and bearings).
- Some turbine manufacturers have sought to address these issues by producing more components in-house and some vertical integration has occurred. This may have a significant impact on the ability of UK based companies to enter certain parts of the supply chain.
- Some wind turbine manufacturers are looking to the UK supply chain to satisfy demand and provide some flexibility in sourcing.
- To make significant inroads into the component and manufacturing supply chain(s), UK based companies must show a commitment to excellence, for what is a highly demanding and (cost) competitive industry.
- There are a number of UK foundries capable of producing large castings for rotor hubs and bedplates, and recent developments in direct drive turbines using permanent magnet and induction generators will lead to a new demand for very large castings for generator housings.
- At approximately 200 tonnes per tower, turbine manufacturers are looking to source locally, which should create opportunities for UK based companies, although some investment in the latest technologies will be needed.
- The UK has a long tradition of supplying structures and service to the offshore sector, and so should be more than capable of supplying to the offshore wind industry.
- There are some materials based R&D activities focused on the wind power industry, primarily composites related, and the UK has a capability to test large turbine rotor blades.

4.8. SWOT Analysis

The Strengths, Weaknesses, Opportunities and Threats for the UK, with emphasis on materials and manufacturing input to the wind industry are given in Table 4.11 below, and includes some of the SWOT analysis of the DTI Summary Report: 'Renewable Energy Supply Chain Gap Analysis', January 2004.

<p style="text-align: center;">Strengths</p> <ul style="list-style-type: none"> • Significant capability in services followed by manufacture and supply of electrical and electronics equipment. • Significant number of UK-based project developers denotes interest in the market and is important because they drive demand. Opportunities for UK depend upon the companies' procurement strategy and the access UK suppliers have to the relevant procurement routes. • Structures and offshore structures fabrication, in particular. • Experience exists across a range of industry sectors with similar skills applicable to the wind sector such as oil and gas, aerospace and shipbuilding. • Presence of rotor blade facility of a major turbine manufacturer (Vestas) • Some wind tower manufacturing capability, including a Vestas site. • Suitable manufacturing sites close to points of use - largely linked to offshore capability. 	<p style="text-align: center;">Weaknesses</p> <ul style="list-style-type: none"> • Manufacture of wind turbines and specialists components – no major wind turbine manufacturer based in the UK and the majority of wind turbine components are imported. • UK suppliers have little or no track record in the manufacturing of wind turbine components, and so experience difficulties in becoming preferred suppliers. • Major turbine manufacturers have established supplier relationships and have undertaken some vertical integration. • Difficulty in contributing to new turbine design (well established) • Time is short to demonstrate capability in component manufacture – margins low, quality requirements are high and some investment in new technologies needed.
<p style="text-align: center;">Opportunities</p> <ul style="list-style-type: none"> • The Renewables Obligation and UK Government commitment means that there is a commitment to wind power in the UK. • There is a very significant market. • The offshore pedigree of UK companies could mean significant opportunities in offshore wind farm construction. • Maintenance and service and related equipment linked to offshore skills. • Manufacture of high mass and size components with high transport costs, such as towers, blades, hubs, rotor shafts • New technology introduction, such as next generation direct drive generators. 	<p style="text-align: center;">Threats</p> <ul style="list-style-type: none"> • Fierce competition from overseas suppliers already supplying to major turbine manufacturers. • Installation of component manufacturing capacity in lower cost, developing countries, which can supply into the UK. • Lack of investment in component manufacturing capabilities. • Planning system delaying approvals for wind farm developments.

Table 4.11 - SWOT analysis for the UK's wind energy industry.

WIND POWER APPENDIX

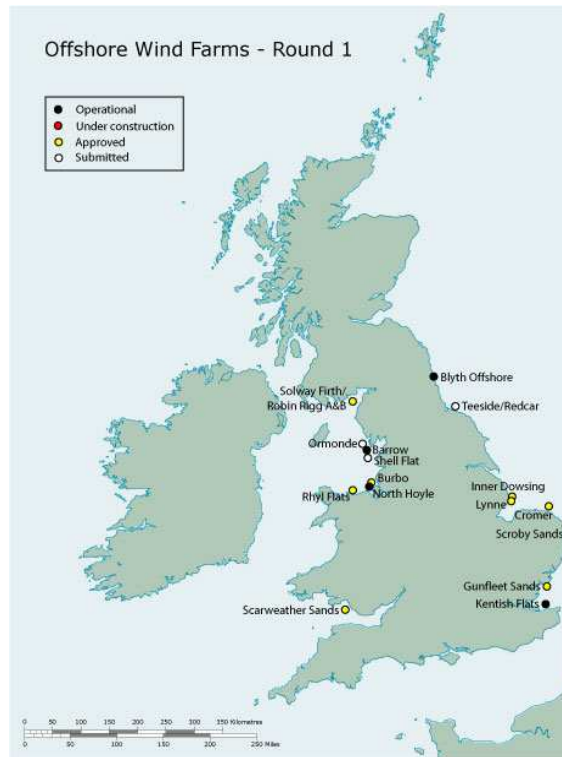

Figure A4.1 - Offshore wind farm locations from Round 1 of the Crown Estate's offshore licensing.

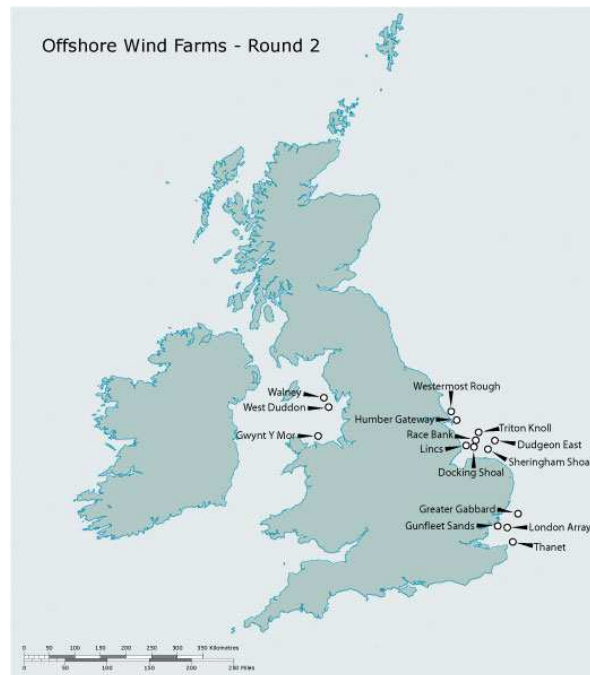

Figure A4.2 - Offshore wind farm locations from Round 2 of the Crown Estate's offshore licensing.

5. WAVE & TIDAL ENERGY

5.1. The Wave & Tidal Power Market Opportunity

The World Energy Council estimates that a potential of 2TW of energy (installed capacity) is available from marine sources, although the amount of this which is recoverable is significantly smaller, as will be described below.

Estimates for the amount of wave energy in the world vary significantly, from 8,000-80,000 TWh/y, although that which is convertible to electricity has been estimated to be between 2,000 and 4,000 TWh/year. For the UK, a practical generating capacity of 700TWh/y has been quoted, almost double today's electricity consumption. However, some of this will prove impractical to harness and estimates of economically recoverable wave energy suggest that wave energy devices could contribute more than 50TWh/y of the UK's energy.

Wave power is much more predictable than wind power and increases during the winter, when the electricity demand is at its highest. Around the UK, which has approximately 35% of Europe's total wave resource, the waves with the greatest energy are situated off the northwest coast of Scotland, where the power (energy per second) averages almost 50kW per metre and can reach 90kW per metre (see Figure 5.1).



Figure 5.1 - European annual average wave power kW/m of crest width (from 'World Offshore Renewable Energy Report 2004-2008', Douglas Westwood, Ltd, 2004).

Seas off the southwest coast of England are also high in potential. Wave energy is highest in open seas, and this energy is reduced as the waves move closer to shore, such that by the time the wave hits the shore, it is estimated that it has lost 90% of its original energy. Therefore, to maximize recovery of wave power, any wave power devices should ideally be located offshore, before the waves lose energy in shallower waters.

The Carbon Trust's Marine Energy Challenge (MEC) estimated that 3 GW of wave and tidal stream capacity could be installed by 2020, generating approximately 8 TWh/y of electricity, which represents 2.1% of electricity supply in 2020. Estimates are that 7.8 TWh/y of this 8 TWh/y resource is near-shore and 0.2 TWh/y is shoreline wave energy. The MEC suggests that this capacity would constitute a substantial proportion of between 1.0 GW and 2.5 GW each of wave and tidal energy expected to be installed across Europe (see Figure 5.2 below).

As is the case for wave power, tidal and current stream energies are both predictable and consistent. However, the longer term potential for tidal energy worldwide is probably still unknown and estimates from different sources are quite varied. For example, a European Commission Joule project reported by Statkraft in Norway, estimated that more than 1000TWh/y can be produced, with half of this being

available in the EU. It is estimated that the UK possesses approximately 50% of Europe's tidal resource. The UK total resource has been estimated at approximately 110 TWh/y, with approximately 22 TWh/y being technically recoverable, thus representing approximately 6% of the UK's electricity demand (Black & Veatch report to the Carbon Trust, 2005).

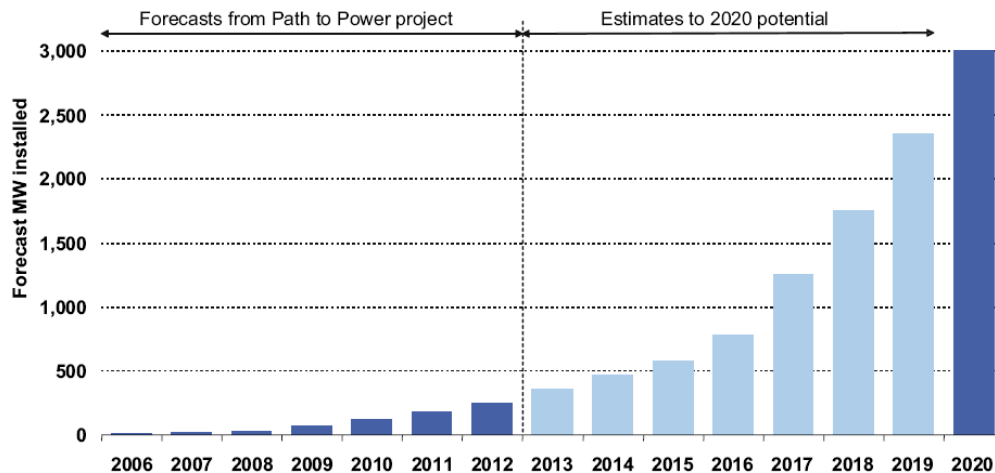

Figure 5.2 - Deployment scenario for wave and tidal energy in the UK to 2020 (from: 'The Path to Power', available at the British Wind Energy Association (BWEA) website: www.bwea.com/pathtopower). (Courtesy of BWEA).

In the short-term, the market opportunities for tidal turbine power have been forecast at a total capacity of 20.9 MW over the period 2004-2008, made up of 15.4 MW from tidal current turbines and 5.5 MW from tidal stream generators. In addition, the forecast for the UK was 17.4 MW out of the 20.9 MW total, or 84% of the total.

The 2003 Energy White Paper indicated that wave & tidal technologies will be commercially available by 2010-2015 and that they will have a significant role to play in the UK's energy provision to 2020, and a report to the DTI ('Renewable Supply Chain Gap Analysis', DTI, January 2004) suggests that a range of between 1400 MW and 4500 MW of installed capacity using marine energy technologies will be deployed by 2020.

Thus, the wave and tidal stream industry is poised to become a significant provider of clean renewable energy for the UK, and in the long-term, marine renewables could meet 15 to 20% of the UK's electricity demand, with 3% to 5% coming from tidal stream and the remainder from wave energy.

Between 2004 and 2008, it has been estimated that the world capital expenditure on wave energy will be £72M, with almost 50% of this in the UK. In the same period, it has been estimated that the world capital expenditure on tidal projects will be around £55M with almost 90% of this being related to the UK market.

Thus together, wave and tidal technologies represent a £90M UK based market for related technologies and services (from The World Offshore Renewable Energy Report 2004-2008, Douglas Westwood Ltd., 2004).

However, and as may be expected, the UK's tidal stream energy resource tends to be located close to headlands in the less accessible areas of the UK, in the north and west, which in turn are also less accessible to the grid infrastructure. Thus, whilst there is enough potential wave power off the UK to supply the electricity demands several times over, the economically recoverable resource for the UK is estimated at 25% of current demand.

5.2. Wave & Tidal Power Development

According to the Carbon Trust, “UK plc has the opportunity and potential to create competitive positions in all areas of design, manufacture, installation and operations of marine renewables”. Whilst acknowledging uncertainties, they estimate that the value of worldwide electricity revenues from wave and tidal projects could be between £60 billion and £190 billion annually. The market for Wave Energy Converters (WECs) alone has been estimated to be worth up to \$500 billion.

The UK has established itself as an early market leader in marine renewable energy, with over 30 technology developers based in the UK, compared to approximately 15 developers in the rest of Europe and approximately 20 developers in the rest of the world. In addition, the UK has established full-scale testing facilities for wave and tidal devices, at the European Marine Energy Centre (EMEC) on Orkney in Scotland and in southwest England, through the ‘Wave Hub’ project (off Hayle, Cornwall), both of which will be described in more detail in Section 6 below. In addition, the New and Renewable Energy Centre (NaREC) in the northeast of England is able to test prototype devices.

Thus, the UK is in a good position to take a significant portion of the world’s marine renewables market, with lead turbine technologies, a number of suitable coastal locations for tidal stream turbine ‘farms’, and strong support from the marine and offshore industries. However, to date, only a few devices have been evaluated as full-scale prototypes.

Both wave and tidal energy devices are at broadly similar levels of development and, therefore, share some common barriers to commercial deployment. A number of countries are active in marine energy developments and successful demonstration of a design is key to establishing a supply base. Thus, given the size of the opportunity, the UK government and government supported bodies have been highly supportive of marine renewables, with a number of funding initiatives.

In 2005, the UK government introduced the Wave and Tidal Energy Demonstration Scheme, providing £50M in funds to support marine energy companies in moving from the development (prototype) phase to commercialization, through the establishment of small-scale arrays.

The Marine Energy Accelerator (MEA) was established in 2006 by the Carbon Trust, with up to £3.5M available for device developers, component technology manufacturers and academic research groups. The MEA aims to support the development of new marine energy device concepts with potential for significantly lower costs than front-runner technologies, as well as R&D into specific component technologies and the development of low cost installation, operation and maintenance strategies.

In early 2007, the Scottish Executive awarded an additional £13M in funds to a total of nine companies aiming to deploy prototypes and small arrays at EMEC. Amongst those companies receiving support were Ocean Power Delivery Ltd. (OPD) (now Pelamis Wave Power Ltd.), Tidal Generation Ltd., Wavegen and Aquamarine Power. The devices of some of these companies will be described in detail below.

As has been mentioned previously, the UK is very well placed to take a significant portion of the world marine energy market, with strengths such as:

- Exceptional wave and tidal resource.
- World leading marine renewable (turbine) technology.
- Increasing interest from the private sector.
- Strong offshore (oil & gas) engineering and fabrication skills.

However, there are a number of obstacles to the deployment of large-scale wave and tidal energy technologies, which are not related to the technologies themselves, but instead to factors such as financing, grid access, and planning and permitting.

Currently, there are few commercial designs that have been successfully demonstrated, which means that there are no (well) established supply chains.

5.3. Overview of Wave & Tidal Energy Devices

As mentioned above, both wave and tidal are at broadly similar levels of development, but there are clear differences between the detailed designs of the different technologies. There are a very large number of concept tidal current stream and wave energy conversion (WEC) devices, with one report estimating that there are almost 300 designs at various stages of development. Over the past two to three years significant progress has been made towards the commercialization of some of these wave and tidal energy devices.

It is beyond the scope of this report to describe in detail the principles of operation of the various devices and only descriptions of some of the leading technologies will be given in Section 5.4 below.

5.3.1. Wave Energy Devices

Wave energy devices, or wave energy converters (WECs) as they are known, can be located on the shoreline, near shore or offshore and operate using a number of principles, some of which are as follows:

- Hinged contour devices: use the relative motion of a series of floating structures to generate electricity.
- Oscillating water column systems: either shoreline based or in floating offshore devices, in which waves are trapped in a chamber and the rise and fall of the water moves a column of air which drives a turbine.
- Point absorbers: use the motion of a buoyant object (a float) to drive a generator.
- Over-topping devices: either onshore or offshore devices, in which waves flow over a structure and electricity is generated by using the falling water to directly, or indirectly, power a turbine.

Perhaps the most advanced wave energy device is the Pelamis device developed by Ocean Power Delivery Ltd. (now Pelamis Wave Power Ltd., of Edinburgh), which uses the hinged contour principle. Details of the Pelamis WEC will be described in detail below (see Section 5.4.1.).

5.3.2. Tidal Energy Devices

Tidal and current stream energy converters are designed to use the ebb and flow of tides and currents to power turbines. In general, tidal devices fall into two main categories, tidal barrages and tidal current turbines, although a third device type (tidal stream generators) are also being developed. Tidal current turbines use tidal currents to turn a rotor which generates electricity, whereas tidal stream generators use the tidal stream to generate power from, for example, the raising and lowering of a hydraulic arm.

There are a large number of sites which are suitable for tidal current turbines and ideal sites are typically approximately 1km offshore in water depths of 20-30 metres. These devices operate using the same principle as wind turbines, and generate power directly from the flow of the tides. The turbine blades can be orientated either horizontally or vertically and the turbines can be either floating or secured to the seabed.

There are several well developed tidal turbine devices, and the first full-scale prototype turbine ('SeaFlow') was developed by UK company Marine Current Turbines Ltd. (MCT, Bristol) and was installed off Lynmouth, Devon in 2003. Subsequently, MCT have developed the 1.2 MW 'SeaGen' device, which is scheduled to be installed at Strangford Lough, Northern Ireland in 2007. Such devices can be installed as single units or can be installed in large arrays in much the same way as wind farms.

Tidal barrages are installed in tidal estuaries or inlets and hold back the flow of water at high/low tides. Electricity is then generated by releasing the water through turbines. Many barrages have been installed around the world and whilst they have proved successful, their high cost and environmental impact mean that current turbines are favoured.

5.4. Lead Wave & Tidal Energy Developers and Devices

In this section, some of the leading, largely UK based, wave and tidal energy devices are described, and reference made to any materials related aspects of their development and construction, as highlighted by the companies themselves.

In general, there have been very few materials related issues or specific materials based development activities, as wave and tidal energy technologies lend themselves to adoption of existing technologies developed for the offshore (oil and gas), marine and wind power markets.

5.4.1. Pelamis Wave Power Ltd. (ex-Ocean Power Delivery Ltd.), Edinburgh

As mentioned above, the wave energy converter (WEC) developed by Pelamis Wave Power Ltd. (PWP) and named Pelamis, is one of the leading marine energy devices. PWP is based in Edinburgh and employs approximately 70 people. The Pelamis device has a similar output to an average modern wind turbine (2.25 MW) and builds upon technology developed for the offshore industry.

The Pelamis device is a semi-submerged, articulated structure composed of three cylindrical sections linked by hinged joints (see Figure 5.3, <http://www.oceanpd.com/>). The wave-induced motion of these joints is resisted by hydraulic rams, which pump high-pressure oil through hydraulic motors via smoothing accumulators. The hydraulic motors drive electrical generators to produce electricity. Power from all the joints is fed down a single umbilical cable to a junction on the sea bed. Several devices can be connected together and linked to shore through a single seabed cable (see Figure 5.4).



Figure 5.3 -The Pelamis Wave Energy Converter (WEC). (Courtesy of Pelamis Wave Power Ltd.: <http://www.pelamiswave.com/>).



Figure 5.4 - An artist's impression of an array of Pelamis WECs. (Courtesy of Pelamis Wave Power Ltd.: <http://www.pelamiswave.com/>).

The machine is held in position by a mooring system and the 750kW machine measures 120 metres long by 3.5 metres wide and weighs 750 tonnes when fully ballasted. Each 750 kW unit contains three Power Conversion Modules (PCMs), each rated at 250 kW.

Pelamis Wave Power's first full-scale pre-production prototype was connected to the UK grid at the European Marine Energy Centre (EMEC) in Orkney in August 2004. The company has received its first commercial contract for the installation of three Pelamis P-750 units, with a total generating capacity of 2.25 MW, which have been assembled and were due for installation at Povoá de Varim, Portugal in September 2007. It is also in the final stages of discussion with Scottish Power for four devices, with a total capacity of 3MW, and has letters of intent with E.ON UK plc (7 devices, 5MW, to be tested at 'Wave Hub' in South West England) and for a further 27 devices in Portugal

Although PWP has no specific development partners, the company has worked heavily with Det Norske Veritas (DNV, Oslo, Norway), the international maritime consultants, and WS Atkins on design issues. In addition, some major power generating companies are involved on a project-by-project basis as follows: Enersis for the installation in Portugal, CRE Energy (part of Scottish Power) for the installation in Scotland and E.ON UK plc for the 'Westwave' project at 'Wave Hub' (described in a little detail in Section 6 below).

There are no materials related barriers to implementing the Pelamis technology and the company consider technology to be available from other industries, with some fine tuning for the WEC application. However, the company stated that it may be that when the designs are being refined to improve efficiency and drive down costs then barriers may be encountered. In addition, although there are currently no materials supply chain related issues, largely related to the low production volumes, this may become more of an issue if volumes were to ramp up.

The Pelamis construction is predominantly steel, which is used for the main tubes and for the housing for the Power Conversion Modules (PCM). Approximately 430 tonnes of steel in are used in each machine, and this was sourced through Corus. For the project in Portugal, the majority of the fabrication and assembly has been carried out in Scotland as follows:

- Camcal, Isle of Lewis, for the main tube structure, which consists of twelve main tube segments (four per machine), with each section being similar in size and length to a train carriage.
- Ross Deeptech, Stonehaven, for the PCM housing.
- Assembly takes place at the PWP facility in Methil, Fife and final assembly of the machines was in Peniche, Portugal.

Suppliers of other components and sub-assemblies include:

- Hydraulic systems: Hytec Hydraulic Engineering Ltd. (Aberdeen) and Hystat System Ltd. (Huddersfield).
- Cables and connectors: Hydro Group plc (Bridge of Don, Scotland).
- Motor/generator sets: Designed and built to Pelamis Wave Power specifications by an external company.
- Anti-fouling paints: Leighs Paints (Bolton), although other suppliers including International Paints (Darwen, Blackburn) provide anti-fouling paint systems.

As regards paint systems, the top side of the structure needs a very good anti-fouling paint system, where as for the underside the best environmental solution must be considered -e.g. to encourage marine growth. Some R&D activities are being carried out by International Paints.

There is also the potential to use concrete for the main tubing structure, mainly to reduce costs, but also for design efficiency, as a concrete structure would not need additional ballast and should give enhanced stress bearing capability. The application of a concrete structure is being investigated in-house with assistance from DNV.

Finally, PWP suggested that although some of the suppliers and contractors used on the project for Portugal are currently considered preferred suppliers, any future projects will be put out to tender.

However, the company would like to keep as much manufacturing as possible in Scotland/the UK, but recognize that there will be financial and sometimes political constraints which make this unfeasible.

5.4.2. Marine Current Turbines Ltd. (Bristol)

Marine Current Technologies Ltd. (MCT) is a private company with various shareholders including; BankInvest, Bendalls Engineering, EDF Energy, Guernsey Electricity Ltd, Seacore Ltd, Triodos Bank, and employs 15 people. MCT are a technology developer and as such do not carry out any manufacturing or sales activities.

MCT's patented technology is a horizontal shaft, submarine tidal current turbine based on using pitch regulated axial flow rotors, which has been successfully demonstrated in an experimental 300kW test system, the world's first commercial scale offshore tidal turbine, called 'SeaFlow', which was installed off Lynmouth in Devon in May 2003 (see Figure 5.5).



Figure 5.5 – Marine Current Turbine's 'SeaFlow' tidal current turbine. (Courtesy of Marine Current Turbines Ltd: <http://www.marineturbines.com/>).

'SeaFlow' is monopile-mounted with a single 11 metre diameter rotor system and uses a dump load in lieu of a grid-connection (to save cost) and only generally operates with the tide in one direction. This phase cost £3.4M and was financially supported by the partners together with the UK DTI, the European Commission and the German government. The 'SeaFlow' technical demonstrator will be taken out of commission when the new turbine ('SeaGen') is installed – see below.

The manufacture of the 'SeaFlow' turbine involved thousands of components and numerous manufacturers and suppliers. The main structural fabrications for the turbine were made by Bendalls Engineering Ltd. (Carlisle), a partner in the UK DTI 'SeaFlow' project. The steel for the project was supplied by Corus, which was also partner in the DTI project.

Bendalls Engineering Ltd. is part of Carrs Milling PLC, and is a large steel fabricator. Bendalls has traditionally specialised in pressure vessels and nuclear plant fabrications, but is seeking to diversify into renewable energy. Bendalls manufactured the structural steel components and the assembly of the device pod and rotor.

The prototype and test-bed for MCT's commercial technology is a 1.2 MW twin rotor, variable pitch system known as 'SeaGen' (see Figure 5.6). Sea Generation Ltd. is the project company, which is a wholly owned subsidiary of Marine Current Turbines Ltd., and has been licensed for a maximum installed duration of 5 years. The device has been manufactured, and installation was to take place at Strangford Lough, Northern Ireland, in August 2007. However, this has been delayed due to damage sustained to the jack-up vessel). 'SeaGen' will be grid-connected and is expected to cost approximately £8.5M, including the connection, and is financially supported by the operating partners and BERR, who have awarded a grant of £4.27M.

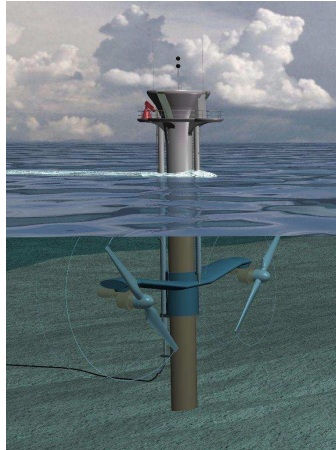

Figure 5.6 – Artist's impression of Marine Current Turbine's 'SeaGen' tidal current turbine.
(Courtesy of Marine Current Turbines Ltd: <http://www.marineturbines.com/>).

The MCT technology borrows strongly from other industries; oil & gas offshore for the superstructure, and wind turbines for the rotors and so at present, no specific materials related developments are needed. Instead, in future, MCT will apply any relevant technologies developed within these industries.

The 'SeaGen' device has two 16m diameter twin bladed turbines (see Figure 5.7), which may be lifted out of the water for maintenance. The 7 metre composite material blades (carbon fibre matrix, wrapped with a glass fibre skin) are manufactured by Aviation Enterprises Ltd. (Lambourn, W. Berks). The rotors allow variable pitch to optimise efficiency, irrespective of tidal flow direction.



Figure 5.7 – Carbon fibre rotor blades for the 'SeaGen' tidal current turbine.
(Courtesy of Marine Current Turbines Ltd: <http://www.marineturbines.com/>).

For the 'SeaFlow' and 'SeaGen' projects, both went through a competitive tendering stage for component / materials supply and all material sourcing for the 'SeaGen' project has been performed by sub-contractors.

MCT have not experienced any significant problems in sourcing materials for the demonstrator designs, although there were some problems obtaining the large bearings for the 'SeaGen' turbine, as the wind energy industry currently has a high demand for these products.

Harland and Wolff (Belfast) have acted as the base for operations for the 'SeaGen' installation, with all components manufactured in various locations within the UK and mainland Europe, and included: BAS Castings Ltd. (Pinxton, Notts.), Bendalls Ltd. (Carlisle), Aviation Enterprises Ltd. (Lambourn, W. Berks), Blackhill Engineering Ltd. (Exeter), Orbital 2 (Powys), Coupe Foundry Ltd. (Preston), Engineering Technology Applications Ltd. (Romsey, Hants), Smart Fibres Ltd. (Bracknell), Deep Sea

Seals Ltd. (Havant, Hants). The significant sub-systems were tested at locations close to MCT's office in Bristol, prior to being delivered to Harland and Wolff for final system assembly and preparation for installation.

The monopile superstructure of the 'SeaGen' device is fabricated from structural steel plates, which are roll formed and welded together. This monopile carries the weight of all the other components, the operating forces on the rotor, and the environmental loads, and was designed to carry all the loads with an acceptable life. The pile is a steel tube 3.5m in diameter below the mud-line and 3.0m diameter above, is approximately 55 metres long, and weighs approximately 270 tonnes.

Although Corus were steel suppliers to the 'SeaFlow' project, the company are not involved in 'SeaGen', and steel fabrication has been carried out by Blatt Industries (Denmark). The technology for placing monopiles at sea is well developed by Seacore Ltd., a specialist offshore engineering company (MCT's largest shareholder).

MCT state that the design life for its tidal turbines will exceed 20 years and that the main monopile support structure can be designed to survive for many decades (the track record of steel offshore structures, providing they are properly protected, is excellent - many offshore oil and gas structures have lasted upwards of 40 years) (see <http://www.marineturbines.com/>). The steel pile and other main structural elements in an MCT tidal turbine have cathodic protection and the rotor is constructed from glass and carbon fibre reinforced composite materials which are not significantly affected by contact with seawater.

It is anticipated that MCT turbines will be installed in arrays of approx. 10 to 20 machines (see Figure 5.8), and that the 'SeaGen' systems will be deployed after testing as a small array under the Marine Renewable Development Fund (MDF).

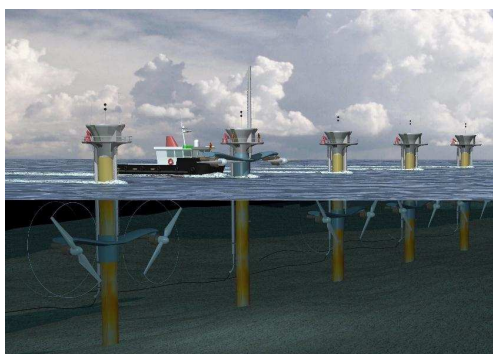

Figure 5.8 – Artist's impression of an array of tidal current turbines.
(Courtesy of Marine Current Turbines Ltd: <http://www.marineturbines.com/>).

5.4.3. Wave Dragon Wales Ltd. (Pembroke Docks)

Wave Dragon Wales, Ltd. is a subsidiary of Wave Dragon ApS, Copenhagen, Denmark and is a leading developer in wave energy technology. Wave Dragon is a technology provider, and will work with a project developer and finance partner from the region in which the technology is deployed.

The company's device, the 'Wave Dragon' is a floating, slack-moored energy converter of the over-topping type that can be deployed in a single unit or in arrays. The first prototype connected to the grid is currently deployed in Nissum Bredning, Denmark. The 'Wave Dragon' device allows ocean waves to over-top a ramp, which elevates water to a reservoir above sea level, where it is stored temporarily. This creates a head of water which is subsequently released through a number of turbines.

The device comprises a central housing, with a large water reservoir, which receives water from oncoming waves via a ramp and an array of hydro turbines, and two lateral wave reflecting arms which concentrate the power of incoming waves (see Figure 5.9).

As mentioned above, a scale model demonstrator project has been successfully completed in Denmark and a 4-7 MW pre-commercial demonstrator, supported by the Welsh Development Agency, is to be deployed 4-5 miles off the Pembrokeshire coast near Milford Haven.



Figure 5.9 - The Wave Dragon device. (Courtesy of Wavedragon : <http://www.wavedragon.net>).

The application for consent of this demonstrator device was submitted in April 2007 and, if granted, construction will start and the device will be deployed at the site in the summer of 2008. The device is intended to be tested for 3-5 years.

Wave Dragon has commissioned the pre-commercial demonstrator project in Portugal, under the Tecdragon name. Partners have been identified and financing is in place, and all construction will be carried out locally (ie, in S. Wales).

The final choice of materials will be dictated by the consortium companies involved in the project, but currently the main construction of the wave reflectors, ramp and reservoir is intended to be fabricated from steel and reinforced concrete, with corrosion protection provided by sacrificial anodes.

The total weight of the device, employing 16 to 18 low-head turbines, is 33,000 tonnes. Mooring consists of slack mooring chains connected to either concrete caissons, steel/concrete gravity blocks or to steel piles.

As regards specific development work for the Wave Dragon, parts of the steel sections on the wave reflectors may be replaced by composite materials to save costs and give maintenance free durability. Currently, forming of the steel for the concreted sections is costly and time consuming. Once the pre-commercial demonstrator is in place, loads will be monitored and an assessment made of areas which are less stressed and hence most suitable for a change in construction methods.

The fabrication of components, etc. will be determined on a project by project basis, and for the pre-commercial demonstrator, local suppliers around Pembroke docks will be used (e.g. Hansons, United Marine Aggregates).

Wave Dragon's low-head Kaplan turbines are currently being supplied by Kössler, GmbH (St. Georgen, Austria), a long-established supplier to the hydropower sector. Currently, only approximately 12 of these units are produced per year. Thus, with the 'Wave Dragon' design, calling for 16-18 units per installation, the company are looking to set up their own manufacturing site in Wales for the production of these turbines. If this is achieved, then all of future supply of turbines for 'Wave Dragon' installations would be from Wales.

Currently, there are no specific materials related issues for the demonstrator project. However, with an installation weight of 33,000 tonnes, there may be supply issues if this technology were to take off.

5.4.4. Wavegen (Inverness)

Wavegen is a wholly owned subsidiary of Voith Siemens Hydro Power Generation (see: <http://www.wavegen.com>). The company has developed small turbo-generators for incorporating into breakwaters, coastal defences, land reclamation, port walls and community power schemes, etc. The technology is based upon the Oscillating Water Column (OWC), with gearbox and hydraulics free turbine power take-off.

The LIMPET (Land Installed Marine Powered Energy Transformer) plant on the island of Islay, off the west coast of Scotland (Islay), is the world's first grid connected commercial scale (0.5 MW) wave energy plant (see Figure 5.10). The plant was commissioned in November 2000. It is a shoreline wave energy converter utilising an inclined oscillating water column (OWC). The Limpet plant is used as a full scale test bed for the development of new turbines.

Wavegen also develop the OSPREY, a near shore Oscillating Water Column (OWC) and are working on a number of similar concept designs.

Currently, a breakwater installation at Mutriku in northern Spain is in the implementation phase and the company has several projects in the development phase including projects in Scotland, at Siadar in the Western Isles, and the USA.



Figure 5.10 - Wavegen's LIMPET device on the Islay coast. (Courtesy of Wavegen: <http://www.wavegen.com>).

Wavegen partners in the projects include RWE npower Renewables and the Basque Energy Board.

The main structure of the OWC is concrete, which can be incorporated into a breakwater structure. Of the other major components, the turbine housing is fabricated from steel plate, the turbine blades are marine grade aluminium and the turbine nose cone is fabricated from GFRP or stainless steel.

Currently, there are no materials related barriers to implementation, although the corrosive environment in which the device operates means that material selection is important; e.g., the shafts for the motors are fabricated from stainless steel, which is costly. In addition, there are no materials related development activities, although when production scales up, there may be opportunities to carry out cost benefit analysis on alternative materials.

Materials are specified by Wavegen, but sourcing is down to the contractors involved. Concrete for the structure will always be sourced local to project. Wherever possible, local contractors will be used, and for the Islay project (LIMPET), companies in and around Inverness were used to fabricate the housing and the motors, and control units were bought in from Europe. Blades for the turbines are made in the UK by Senar.

Wavegen does not have specific component supplier partners, but to date, Senar has provided turbine blades, BCP (Brook Crompton) has supplied the motors and Howden has provided the housings for one of the test units.

As regards materials or component supply issues, the long lead times on motors, has led Wavegen to look at alternative supply.

5.4.5. Ocean Power Technologies Ltd. (Warwick)

Ocean Power Technologies, Ltd. (OPT) is a wholly owned subsidiary of Ocean Power Technologies Inc., Pennington, NJ, USA and employs 12 people at its UK site and 40 worldwide.

OPT's proprietary PowerBuoy® technology (<http://www.oceanpowertechnologies.com>) captures wave energy using large floating buoys anchored to the sea bed and converting the energy into electricity using innovative power take-off systems (see Figure 5.11). The device uses a rugged, simple steel construction and utilizes conventional mooring systems. To date, ocean trials have been conducted off the coast of New Jersey and 40 kW-rated PowerBuoys® have been installed in Hawaii and New Jersey.



Figure 5.11 - Ocean Power Technologies PowerBuoy®. (Courtesy of Ocean Power Technologies Ltd.: <http://www.oceanpowertechnologies.com>).

OPT has begun the initial phase of installation of a turnkey 1.39 MW wave farm off the northern coast of Spain, which is due for completion in the summer of 2008. This project is a joint venture with the Spanish utility Iberdrola SA, and a full size demonstration plant of up to 5MW capacity is planned for installation in UK waters. OPT has two demonstrator projects planned for the UK, one funded by the Scottish Executive and due for installation off Orkney at EMEC and the other funded by the Southwest England Regional Development Agency, and planned for installation at Wave Hub.

The technology is scaleable and arrays of devices are envisaged – see Figure 5.12 below:

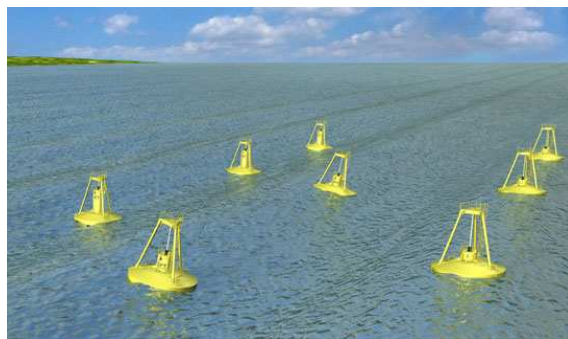

Figure 5.12 – An artist's impression of an array of Ocean Power Technologies PowerBuoy® devices. (Courtesy of Ocean Power Technologies Ltd.: (<http://www.oceanpowertechnologies.com>)).

Currently, OPT does not have UK based partners and partners include the US Navy, Penta-Ocean Construction (Japan), Iberdrola (Spain), Total S.A. (France, Spain) and Lockheed Martin.

Steel is used predominantly in the construction of the super structure and the power take off unit consists of hydraulics and electronic equipment. Synthetic materials are being considered for the mooring, to give additional compliance to the system in the event of extreme weather, and it is hoped that this will also be a cheaper solution.

There are no materials related barriers to implementation, no materials supply issues and no current materials related development activities, as the technology is still in its early stages of development. However, when more buoys have been installed, there may be opportunities to look at alternative materials for cost reduction and weight saving. In this respect, the central spar column would be an ideal candidate for weight reduction. Anything above the surface is considered non critical in terms of weight as it is self-supporting.

The power take off units are currently fabricated in-house, but this may be sub-contracted out once production increases. The structure is a simple construction and is fabricated close to where the units will be installed by local sub-contractors. OPT do not get involved in specifying materials sourcing, which is left to the sub-contractors.

5.4.6. Selected Other Technology Developers

Other active technology developers include Open Hydro, Ltd. (Dublin, Ireland), which has a 0.25 MW development device, soon to be upgraded to 0.5 MW, under test at the EMEC site in Orkney. Open Hydro has recently signed an agreement with Alderney Renewable Energy Ltd. (ARE) for the deployment of tidal turbines in Alderney's territorial waters. In addition, a pre-commercialisation Fred Olsen 'Buldra' rig, which uses the vertical movement of floating buoys suspended under a floating platform, will be installed at the Wave Hub facility in SW England in 2009.

Oceanlinx Ltd. (Botany, NSW, Australia), the Australian marine energy developer has signed a letter of intent with the SWRDA to deploy a 5 MW Oscillating Water Column (OWC) device at the Cornwall Wave Hub. To date, Oceanlinx have deployed a 450 kW device off Port Kembla, Australia and have several other projects under development around the world.

Aquamarine Power Ltd. (Edinburgh) and Queens University Belfast are developing the Oyster™ system, a near-shore bottom-mounted, shallow water, wave energy converter, with support from the Technology Strategy Board (TSB). The peak power generated by each Oyster™ unit is between 300 and 600kw, and a demonstrator device is to be installed at EMEC site in 2007.

The project to develop the hydroplane 'Stingray' device of the Engineering Business Ltd. has been put on hold because the company cannot sustain development activities on a non-profit basis. Similarly,

the 'TidEL', tidal turbine, project of SMD Hydrovision was put on hold in 2005, as a result of company resource issues (other core projects taking priority). Thus, although there is considerable support for marine energy activities, these projects illustrate the difficulties in maintaining the associated high development costs.

At this time (late 2007), a feasibility study for a tidal barrage across the Severn Estuary is ongoing. A Severn barrage could have a capacity of up to 8,640 MW and an estimated output of 1.7 TWh/y.

The Yorkshire based company, Lunar Energy Ltd. (Hessle, E. Yorks.) is developing the RotechTidal Turbine (RTT) device, and E.ON UK plc and Lunar Energy are to develop a tidal stream power project of up to 8MW somewhere off the west coast of the UK.

ScottishPower plc and the Norwegian company Hammerfest Strom have created a company called Hammerfest UK, which will develop a full-scale prototype of Hammerfest's tidal turbine device, and which will be installed at EMEC in 2009.

5.5. Wave & Tidal Energy Supply Chain Structure

A large number, and a wide range, of companies are involved in the marine renewable sector, and Figure 5.13 below shows the key segments of the sector. However, as mentioned above, few projects have progressed to the pre-commercialisation stage and so, as yet, there are no common strategies for procurement and contracting.

Different members of the supply chain are responsible for different parts of projects depending on the type of project and its stage of development. Key classes of firms that are involved in the supply chain include Legal firms, Financial firms, Insurance firms, Marine Service firms, Technology Developers, Manufacturers, Test Facilities, Project Developers, Installation Contractors, and Energy Majors/Utilities (Scottish Enterprise document).

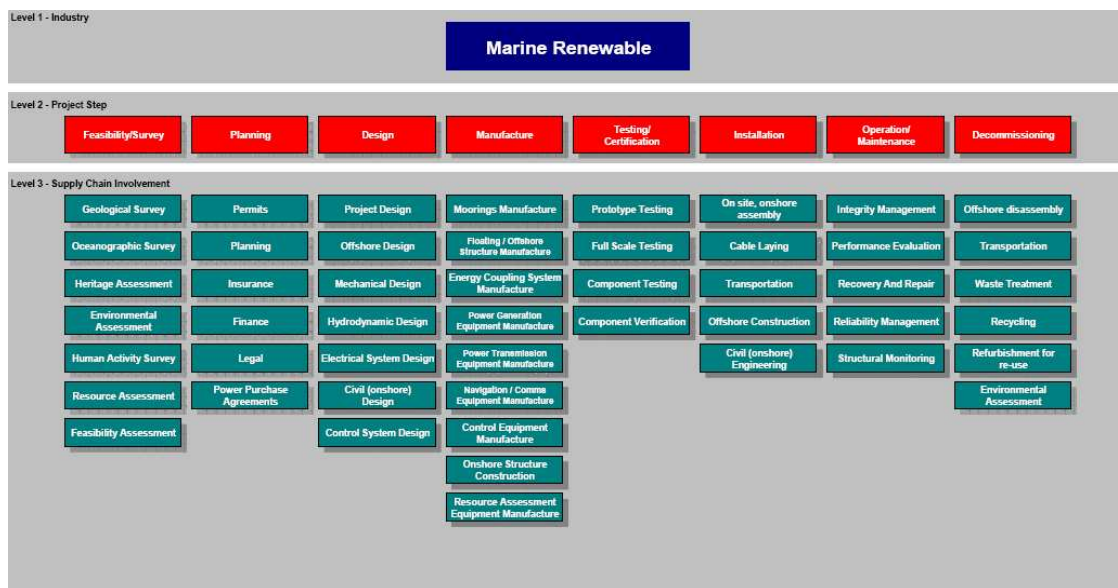

Figure 5.13 - Segmentation of the marine renewable sector (from: 'Marine Renewable (Wave and Tidal) Opportunity Review: Introduction to the Marine Renewable Sector', Dec. 2005, Scottish Enterprise, <http://pugetsoundtidalpower.com/TidalPower/Tidal%20Oppty%20Review.pdf>). (Courtesy of Scottish Enterprise: <http://www.scottish-enterprise.com/>).

5.6. UK R&D Activity in Wave & Tidal Energy Materials

There is a high level of research and development activity related to wave and tidal energy ongoing within the UK, and a large proportion of the development work is currently centred on industry rather than academia.

Established in 2003, the 'Marine Energy Consortium' of the EPSRC's SUPERGEN initiative has received approximately £2.6M in funding and has a number of research themes aimed at addressing gaps in current understanding of the fundamental and advanced science and engineering issues of marine energy (www.supergen-marine.org.uk). However, little activity is dedicated to materials issues.

The SUPERGEN Marine Consortium academic partners are: the University of Edinburgh (Prof. Robin Wallace, lead), Heriot-Watt University, the University of Lancaster, Robert Gordon University and the University of Strathclyde and Queen's University, Belfast. In addition, there are a large number of industrial partners, further information on which can be found at the Consortium website.

An extensive list of 'Ocean Energy' R&D activities can be searched at the UK Energy Research Centre (UKERC) Research Atlas (specifically the Research Register) (<http://ukerc.rl.ac.uk/ERA001.html>).

Further information on R&D activities related to marine energy development, see the report: 'Marine Renewable (Wave and Tidal) Opportunity Review: Introduction to the Marine Renewable Sector', December 2005, Scottish Enterprise).

As mentioned above, the UK has pioneered the establishment of shared facilities for testing of wave and tidal devices such as the European Marine Energy Centre (EMEC) in Scotland and the 'Wave Hub' project in southwest England. These facilities are helping develop standards for marine energy devices.

5.6.1. The European Marine Energy Centre (EMEC), Ltd

EMEC was established to help the evolution of marine energy devices from prototypes to commercial implementation (www.emec.org.uk). Based at Stromness in Orkney, EMEC is the first centre of its kind in the world. Wave and tidal energy devices can be connected to the National Grid via seabed cables, and to date, Government and other public sector organisations have invested approximately £15M in the creation of the centre and its two marine laboratories.

5.6.2. 'Wave Hub'

The 'Wave Hub' project for a test wave farm facility has been approved for £21.5M of funding from the South West of England Regional Development Agency (RDA), and the total cost of the project will be £28M (www.wavehub.co.uk).

'Wave Hub' will be located off the coast of Cornwall in South West England and the project could generate £76M over 25 years for the regional economy. It would create at least 170 jobs and possibly hundreds more by creating a new wave power industry in South West England. It will provide a high voltage cable 10 miles out to sea and connected to the National Grid. Companies will be able to test their wave energy devices in a leased and consented area of sea.

Wave Hub is essentially an electrical 'socket' on the seabed around 10 miles (18.5 km) off Hayle on the Cornwall coast in South West England. It will be connected to the National Grid by a 15.5 mile cable linked to a new electricity substation at Hayle and could generate 20 MW of electricity.

Three wave device developers have already been chosen to work with the South West RDA on the project. They are Ocean Power Technologies Limited, Fred Olsen Limited and WestWave, a consortium of E.ON UK plc and Ocean Prospect Ltd., using the Pelamis technology of Pelamis Wave Power, Ltd.

5.6.3. The New and Renewable Energy Centre (NaREC)

The New and Renewable Energy Centre (NaREC) in Blyth, Northumberland offers testing and development capabilities in-house for marine renewable device developers, typically at 1/10th scale (<http://www.narec.co.uk>). NaREC has test facilities for large scale wave testing, large scale tidal testing and small scale marine device testing at the University of Newcastle.

Trials at NaREC's large-scale tidal testing facility based at the Tees Barrage (Stockton-on-Tees) have taken place involving a tidal turbine prototype known as 'Evopod', developed by the marine consultancy Overberg Ltd.

5.7. Summary

The following gives a summary of the status of the UK's wave and tidal energy industry:

- It is estimated that the UK possesses approximately 35% of Europe's wave resource and 50% of Europe's tidal resource, and in the long-term, marine renewables could meet 15 to 20% of the UK's electricity demand, with 3% to 5% coming from tidal stream and the remainder from wave energy.
- The 2003 Energy White Paper indicated that wave & tidal technologies will be commercially available by 2010-2015 and that they will have a significant role to play in the UK's energy provision to 2020, with a range of 1400 MW to 4500 MW of these technologies being deployed by 2020.
- The UK has established itself as an early market leader in marine renewable energy, with over 30 technology developers based in the UK, compared to approximately 15 developers in the rest of Europe and approximately 20 developers in the rest of the world.
- The UK is very well placed to take a significant portion of the world marine energy market, with strengths such as:
 - Exceptional wave and tidal resource.
 - World leading marine renewable (turbine) technology.
 - Increasing interest from the private sector.
 - Strong offshore (oil & gas) engineering and fabrication skills.
- The UK has pioneered the establishment of shared facilities for testing of wave and tidal devices such as the European Marine Energy Centre (EMEC) in Scotland and the 'Wave Hub' project in South West England.
- Currently, there are few commercial designs that have been successfully demonstrated, which means that there are no (well) established supply chains and common strategies for procurement and contracting.
- In general, there have been very few materials related issues or specific materials based development activities, as wave and tidal energy technologies lend themselves to adoption of existing technologies developed for the offshore (oil and gas), marine and wind power markets.
- There is a high level of research and development activity related to wave and tidal energy ongoing within the UK. However, little activity is dedicated to materials development.

5.8. SWOT Analysis

Table 5.1 below gives a summary of the Strengths, Weaknesses, Threats and Opportunities of the UK's marine energy industry.

<p style="text-align: center;">Strengths</p> <ul style="list-style-type: none"> • The UK is the world leader in wave and tidal technology development. • World-class experience in the development and evaluation of wave energy conversion (WEC) devices • Strong offshore and marine engineering capabilities. • The UK's tidal and wave energy resource is immense • The UK has established two major demonstration and test centres which may allow the UK to set the international benchmarks for evaluating marine renewable devices • There are demonstration projects currently operating in the UK. • The UK has a large number of companies with experience in the planning, development (fabrication / construction), and operation (including service and maintenance) of offshore structures. • Some small-scale supply chains have developed around prototyping and demonstration projects. 	<p style="text-align: center;">Weaknesses</p> <ul style="list-style-type: none"> • There is no stable design and all designs are unproven, although some front-runner technologies are emerging. • Technical, economic and performance risks remain. • The energy supply from marine renewables is intermittent.
<p style="text-align: center;">Opportunities</p> <ul style="list-style-type: none"> • There is a massive resource globally and a potentially large market in the UK and overseas. • The UK has the opportunity of establishing a 'winning' design and developing a supply base centred in the UK. • Distinct synergies exist with the offshore industry (including wind). This means that the UK can build on existing strengths and develop wave and tidal service capabilities. • The UK's offshore industry is looking to diversify from its traditional business, and many within that industry see offshore renewables as an area of opportunity in which they can exploit their existing skills and experience. 	<p style="text-align: center;">Threats</p> <ul style="list-style-type: none"> • A non-UK design may become the preferred device (although there may still be significant opportunities for UK based fabrication, operation, service, etc.). • Uncertainty over market volumes can act as a barrier to the investment required to make the transition from a prototype supplier to a commercial supplier. • Longer-term, manufacturing may be hosted in countries with low cost labour.

Table 5.1 - SWOT analysis for the UK's marine energy industry.

6. SOLAR PHOTOVOLTAICS (PV)

6.1. The Solar Photovoltaics (PV) Market

The world solar photovoltaics (PV) market is growing very rapidly, and installations of PV cells and modules around the world have been growing at an average annual rate of more than 35% since 1998. However, the total installed capacity still only represents less than 0.1% of the global electricity generating capacity.

By the end of 2006, approximately 6,500 MW of PV capacity had been installed, and global market survey data show that between approximately 1,500 MW and 1,750 MW of capacity was installed in 2006 alone (see Figure 6.1 below and <http://www.solarbuzz.com/Marketbuzz2007-intro.htm>).

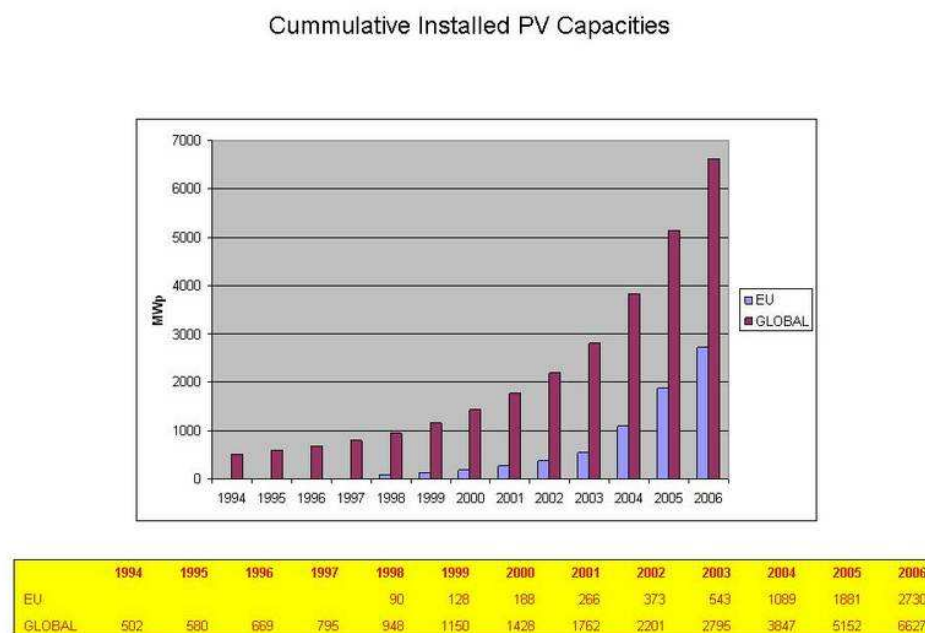

Figure 6.1 - Cumulative global and European installed solar PV capacities. (Courtesy of the European Photovoltaic Industry Association (EPIA): <http://www.epia.org/>).

In addition, in 2006, manufacturer shipments were 1,982 MW, a 41% increase over the previous year and the total PV cell production in 2006 was 2,536 MW, up from only 287 MW in 2000.

The European Photovoltaic Industry Association (EPIA) and Greenpeace 'Advanced Scenario' (see 'Solar Generation IV - 2007', available for download at <http://www.epia.org/>) shows that by the year 2030, PV systems could be generating approximately 1,800 TWh of electricity around the world. In the same scenario, the capacity of annually installed solar power systems would reach 179 GWp by 2030.

Currently, the global PV industry is worth an annual €9 billion and the industry employs over 70,000 people. It is expected that the global PV market will continue to grow at a high level, with a consolidation towards approximately 19% per annum in 2020, resulting in a full-time employment potential of 1.9 million people.

In 2005, the European Commission published 'A Vision for Photovoltaic Technology' (see: <http://ec.europa.eu/research/energy/pdf/vision-report-final.pdf>), which suggests that PV can generate

4% of the world's electricity and create between 200,000-400,000 new jobs in Europe by 2030, based on a projected 20-40 GWp market.

Most current solar PV module capacity is in Japan, Germany and the USA, which together account for 90% of the total installed capacity, and 95% of the capacity installed in 2005.

Of the 6,500 MW of global installed PV capacity, approximately 3,000 MW of this is installed in Germany, and solar PV currently contributes approximately 0.4 percent of German electricity generation. This rapid adoption of solar PV electricity generation in Germany has been stimulated by a 'feed-in tariff' program, under which the utilities buy solar PV generated electricity at a higher rate than the consumer pays for the power.

Perhaps not surprisingly, the UK PV market has been relatively slow to develop and by the end of 2005, there were approximately 1,300 installed systems and a total of 10.9 MW of installed capacity, 2.7MW of which was installed during 2005.

However, The Department of Business Enterprise and Regulatory Reform's (BERR's) Low Carbon Buildings Programme (and local and regional) authority requirements that a significant proportion of new building energy needs to be met via renewable sources has provided a major stimulus to the UK market for building integrated PV (BIPV) systems, and the UK market is now expected to grow more rapidly, at in excess of 3.2 MW per annum in the short-term.

6.2. The Manufacture of Solar PV Systems

6.2.1. Global PV Cell and Module Manufacture

According to data from Photon International, in 2006, manufacturers produced 2,536 megawatts (MW) of solar cells worldwide, with 36% of those cells coming from Japanese manufacturers (eg, Sharp and Kyocera), 20% from German companies (eg, Q-Cells and Schott Solar), and 15% from Chinese producers (eg, Suntech Power) – see Figure 6.2 below

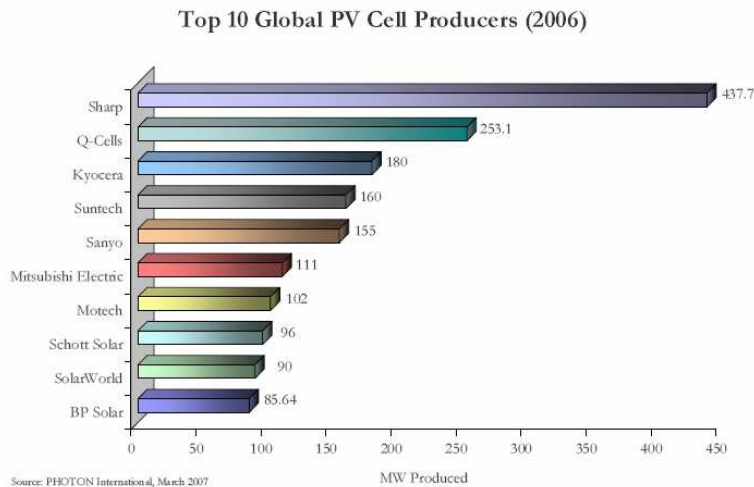

Figure 6.2 – Top 10 global PV cell producers (from: Photon International, 2007).

Of these manufacturers, Sharp, the market leader, has its European module assembly plant at Wrexham. Further details of the Sharp facility and those of other UK based solar PV supply chain companies will be described in Section 6.3 below.

6.2.1. Solar PV Cell Technology

Only a very brief description of the PV materials and systems technologies are given here and further information can be found, for example, in the EPIA / Greenpeace 'Solar Generation IV - 2007' document – see <http://www.epia.org/>.

A solar PV system typically consists of a large number of cells which are assembled into a module or panel (see Figure 6.3). More than 90% of PV cells are made either from single crystal or polycrystalline silicon wafers, sliced from ingots or castings (see Figure 6.4).



Figure 6.3 – A solar PV module assembly and large solar system.

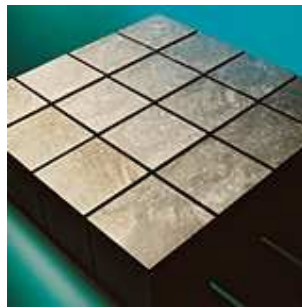

Figure 6.4 – Pure multi-crystalline Si ingot, cut into 'bricks'.
(Courtesy of PV Crystalox Solar plc: <http://www.crystalox.com/>).

In addition, PV cells can be produced via thin film technology in which ribbons or thin films of materials such as amorphous and microcrystalline silicon, cadmium telluride and copper indium (gallium) diselenide (CIS or CIGS) are deposited in thin layers on a low-cost backing (eg, glass, stainless steel or plastic).

Data from the European Photovoltaic Industry Association (EPIA) indicate that the relative shares of the different PV technologies are: multi-crystalline Si (46.5%), monocrystalline Si (43.4%), amorphous Si (4.7%), CdTe (2.7%), ribbon sheet, crystalline Si (2.6%) and CIS (0.2%) (see: <http://www.epia.org/>).

As raw materials costs represent a significant fraction of the manufacturing costs of PV cells, considerable effort is currently being devoted to activities aimed at reducing the thickness of the Si, through techniques such as improved wafer sawing, thin layer extraction from the melt and Si powder melting. Significant effort is also being directed towards increasing the efficiency of the cells (£'s / Wp) and typical cell efficiencies are shown below in Table 6.1.

Technology	Efficiency
Monocrystalline Si	12-15%
Polycrystalline Si	11-14%
CIGS	9-9.5%
Cadmium Telluride	6-7.5%
Amorphous Silicon	5-7%

Table 6.1 - Efficiencies of the various Solar PV cell technologies
(from: <http://www.crystalox.com/>)

Thin film cells are constructed by depositing extremely thin layers of photosensitive materials onto a low-cost backing such as glass, stainless steel or plastic, and three types of thin film modules are commercially available at the moment. These are manufactured from amorphous silicon (a-Si), copper indium diselenide (CIS, CIGS) and cadmium telluride (CdTe). Although the efficiency rates are considerably lower for thin film cells, the manufacturing costs are lower than those of crystalline silicon technologies. EPIA expects a growth in the thin film market share to reach about 20% of the total production of PV modules by 2010.

Recently, the supply of silicon has been an issue, with the demand for solar grade silicon now exceeding that from the semiconductor industry (at approximately 23,000 tonnes in 2007), which has led to an increased market share of cells produced via thin film technologies and several companies are working a high throughput roll-to-roll (continuous) production approach, using a flexible substrate which is coated with the thin film layer(s).

In addition to crystalline silicon and thin film cells, the use of concentrators and high efficiency cells such as GaIn and GaAs are also being developed, as are thin-film excitonic (largely organic and dye sensitised) cells. Descriptions of these technologies are beyond the scope of this work.

Finally, inverters are used to convert the direct current (DC) power generated by a PV generator into alternating current (AC) compatible with the local electricity distribution network.

6.3. The UK Solar PV Supply Chain

UK companies have been at the forefront of development in PV technologies, and the UK hosts a number of key players in the PV sector:

6.3.1. PV Crystalox Solar plc (Abingdon, Oxfordshire)

PV Crystalox Solar plc ('Crystalox' <http://www.crystalox.com/>) currently employs approximately 200 people and was established in 1982. The company is a market leader in refining silicon ingots for wafer production and was the first company to develop multi-crystalline technology on an industrial scale.

Production of Si ingots takes place in the Oxfordshire (United Kingdom) plant, which are then sent for wafer manufacture at the Crystalox facility in Erfurt (Germany) plant and to outsourced fabricators in Asia. Approximately 25% of output is sold in the European market and 75% in the Asian market, and production output in 2006 will produce 215 MW per annum.

In addition, Crystalox are now building a solar grade silicon facility in Bitterfeld, Germany, which will ease its concerns regarding the supply of silicon. The facility will be completed by the end of 2008 and will be put into operation at the beginning of 2009. It is expected that annual production will reach 900 tonnes in the first year of operation, and that, thereafter production is expected to increase to 1,800 tonnes.

6.3.2. Sharp Electronics UK (Wrexham)

Sharp UK (<http://www.sharp.co.uk/page/solar>), the global market leader, has its European module assembly plant at Wrexham, where production capacity is increasing to 220 MW per annum. This facility has been manufacturing solar modules since 2004, and assembles monocrystalline and polycrystalline solar modules for use in both residential and commercial installations throughout Europe.

6.3.3. ICP Solar Technologies (UK) Ltd. (Bridgend, Mid-Glamorgan)

ICP Solar (<http://www.icpsolar.com/>) produces amorphous silicon based solar cells for integration into solar panel based products. In October 2007, ICP Solar Technologies Inc. (Montreal, Canada) sold the majority of its shares to Innovative Systems Engineering (ISE) Solar, a leading provider of vacuum deposition equipment, based in Warminster, Pennsylvania.

The company have a thin film PV manufacturing facility in Bridgend and will build a new solar cell manufacturing plant in Cardiff.

6.3.4. G24 Innovations Ltd. (Wentloog, Cardiff)

G24 Innovations Ltd. (<http://www.g24i.com/>) has established a £60M dye sensitised solar cell manufacturing facility at Wentloog, Cardiff, with a capacity of up to 200 MW per annum (by the end of 2008). The specific solar cell technology is licensed from Konarka Technologies, Inc. (Lowell, MA, USA), and the facility is supported with investment from the Welsh Assembly Government. The company will initially target the market for mobile consumer led products (eg, mobile phone chargers, MP3 players, laptop computers etc.), but believes that there is an opportunity to integrate the cells into buildings.

6.3.5. Romag Ltd. (Consett, Co. Durham)

Romag (<http://www.romag.co.uk/>) is a leader in the manufacture of modules for integration of PV into commercial and industrial building. Romag's 'PowerGlaz' is a Building Integrated Photovoltaics (BIPV) system designed for use on glazed facades and glass roofs. An example the application of 'PowerGlaz' panels (installed by Solar Century Ltd) can be seen at the new education and research facility (the 'Core') at the Eden Project in Cornwall.

In June 2006, Romag announced a major expansion of its photovoltaic production capacity at its facility in Consett. This increase in capacity was expected to come on line in the second half of 2007, to meet the expected significant increase in demand for solar PV systems in both the UK and Europe.

6.3.6. Selected Other Organisations in the UK PV Supply Chain

In addition to the above, other global players in the solar PV industry are currently considering the UK as a base for production facilities.

The New and Renewable Energy Centre (NaREC) in Blyth, Northumberland have a silicon cell development facility that is also capable of small scale production of bespoke solar cells and modules (e.g. concentrator and coloured cells), using Laser Grooved Buried Contact (LGBC) technology. The LBGC process is highly flexible allowing high efficiency silicon solar cells to be made for a range of shapes and sizes.

The UK market leader in the design and installation of solar technology systems in the built environment is Solar Century Ltd. (London).

6.4. UK R&D Activity in Solar PV Materials

The UK has a world class solar energy research community which is based on the UK's strengths in solid state physics and photonics.

This section is not meant to give an exhaustive list of UK based solar PV research activities, but instead highlights some of the major publicly funded activities. An extensive list of 'Solar Energy: Photovoltaics' R&D activities can be searched at the UK Energy Research Centre (UKERC) Research Atlas (specifically the Research Register) (<http://ukerc.rl.ac.uk/ERA001.html>).

Solar PV research in the UK is largely funded by the Engineering and Physical Sciences Research Council (EPSRC). However, in addition to companies' internal research activities, some pre-competitive industrial Research and Development projects are supported by BERR, and now the Technology Strategy Board, through the Emerging Energy/Low Carbon priority of the Collaborative R&D Programme.

Before describing these activities, it is worth noting that between 2000 and 2005, the Department of Trade and Industry (DTI) supported 'The UK Photovoltaic Domestic Field Trial (PV DFT)', which was the first widespread monitoring of PV systems in domestic buildings in the UK. The DFT involved a total of 28 projects, installing PV systems on a wide variety of domestic buildings, and with a total installed capacity is 742kWp.

The PVDFT programme collected extensive data from across the country providing detailed information on system design, installation, performance and reliability. This has been used to refine the guidelines for monitoring work, to improve the design of PV systems, to develop best practice guidelines, and to provide a basis for recommendations and the development of 'Good Practice Guidelines' (see: <http://www.berr.gov.uk/files/file36660.pdf>).

6.4.1. EPSRC Supported Activities

The EPSRC Sustainable Power Generation and Supply (SUPERGEN) Programme currently supports two multi-disciplinary consortia focused on advanced PV materials:

1. The 'Photovoltaic Materials for the 21st Century Consortium' (see <http://www.pv21.org/intro.htm>) was launched in April 2004, with funding of £4.2M over 4 years. The consortium comprises 6 Universities and 7 companies, with the aim of developing low-cost thin-film solar cell devices fabricated from inorganic semiconductors. The partners are:
 - Universities: University of Wales, Bangor (Prof. Stuart Irvine, consortium lead), University of Durham, University of Bath, University of Southampton, Loughborough University, University of Northumberland.
 - Companies: PV Crystalox Solar plc, Oxford Lasers Ltd, Kurt J. Lesker Co Ltd, Millbrook Scientific Instruments plc, Epichem Ltd, MATS (UK) Ltd, Gatan UK, Antec Solar GmbH and Jantec Ltd.

Technical achievements so far include the development of an innovative electrochemical deposition method for copper indium diselenide (CIS) PV. This thin film process has the potential for considerable cost reductions.

2. The 'Excitonic Solar Cells Consortium' (see <http://www.bath.ac.uk/chemistry/supergen-ESC/>), is researching 'non-conventional' solar cells (dye sensitized and organic solar cells), which may offer the possibility of low toxicity, flexible and easy to manufacture PV materials. Consortium members are concentrating on understanding the factors which limit efficiencies as well as on combining their expertise to devise entirely new types of solar cell. The project received initial funding of £1.1M and the partners are:
 - Universities: University of Bath (Prof. Laurie Peter, consortium lead), University of Cambridge, University of Edinburgh, Imperial College, London.
 - Company: Cambridge Display Technology Ltd.

6.4.2. Activities within the Technology Strategy Board's (TSB) Collaborative R&D Programme

The activities described below formed part of the 'Emerging Energy Technologies: Low Carbon Energy Technologies' component of the Department of Trade and Industry's Technology Programme (now part of the Technology Strategy Board's Collaborative R&D Programme).

1. 'High Efficiency Solar Panels Based on Multi-Layer Graded and Gap CIGS'
 - The project aim is to investigate and develop a novel semiconductor deposition process for CuInGaSe_2 (CIGS) based solar panels.
 - Project partners are: Ionotec Ltd (Lead), Sheffield Hallam University and Pilkington plc.
 - Total Project Cost is: £637,410, with the Collaborative R&D Programme providing: £395,490.
 - The project started on 3 October 2005 and runs for 36 months.
2. 'Polymer Photovoltaics'
 - The project aim is to develop PV devices based upon polythiophene based polymers and co-polymers.
 - Project partners are: Merck Chemicals Ltd, Imperial College London, BP Solar Ltd, Dupont Teijin Films UK Ltd.
 - Total Project Cost is: £1,170,365, with the Collaborative R&D Programme providing: £605,991.
 - The project started in September 2006 and runs until 31 March 2008.
3. 'The Development of Advanced Low Cost InP Based Photovoltaic Devices'
 - This project aim is to develop PV devices based upon InGaAs/InP and InP devices grown on Si substrates.
 - Project partners are: Centre for Integrated Photonics (Ipswich, Lead), University of Oxford, Wafer Technology Ltd.
 - Total Project Cost is: £668,558, with the Collaborative R&D Programme providing: £223,730.
 - The project started on 3 October 2005 and runs for 36 months.
4. 'Sputtered Semiconducting Silicon For Large Area Flexible Solar Cells'
 - The project aim is to develop a viable, low cost commercial process for large area flexible solar cells, for applications such as building integrated photovoltaics (BiPV) and appropriate stand alone systems.
 - Project partners are: Plasma Quest Ltd., Romag Ltd and University of Southampton.
 - Total Project Cost is: £743,162, with the Collaborative R&D Programme providing: £511,678.
 - The project started in December 2006 and runs until 31 March 2009.
5. 'Feasibility of PV Coating on Steel, Based on Dye-Sensitised Titania'
 - The project aim is to develop functional photovoltaic (PV) coatings, by integrating dye sensitised solar cell (DSSC) technology into coatings of strip steel.
 - Project partners are: Corus UK Ltd (Lead) and Becker Industrial Coatings Ltd.
 - Total Project Cost is: £455,493, with the Collaborative R&D Programme providing: £227,746.
 - The project started on 8 January 2007 and runs for 12 months.

BERR have recently awarded £1.2M to NaREC for a Building Integrated Photovoltaics (BiPV) programme, in which wafer, cell and module manufacturers (including PV Crystalox and Romag) will work together on a range of speciality BiPV modules.

It is also anticipated that additional solar PV related projects will be supported from the Technology Strategy Board's competition of April 2007.

In addition to the above, four central facilities of relevance to the PV community have been identified: the III-V facility at Sheffield University (<http://www.shef.ac.uk/eee/research/nc35t>), The New and Renewable Energy Centre's (NaREC) PV Technology centre (<http://www.narec.co.uk/>), the University of Northumbria's PV testing facility (<http://soe.unn.ac.uk/npac/npac.htm>), and Southampton University's PV systems test facility (http://www.energy.soton.ac.uk/research/solar_campus.html). Details of the capabilities of these facilities are described in detail elsewhere (see UK Energy Research Centre (UKERC) report: 'A Roadmap for Photovoltaics Research in the UK', August 2007: REF UKERC/RR/FSE/2007/001), and further information can be found at the facility websites.

6.5. Summary

The following gives a summary of the status of the UK's Solar PV energy industry:

- The world solar photovoltaics (PV) market is growing very rapidly, and installations of PV cells and modules around the world have been growing at an average annual rate of more than 35% since 1998.
- The UK PV market has been relatively slow to develop and by the end of 2005, there were approximately 1,300 installed systems and a total of 10.9 MW of installed capacity, 2.7MW of which was installed during 2005.
- However, The Department of Business Enterprise and Regulatory Reform's (BERR's) Low Carbon Buildings Programme (and local and regional) authority requirements that a significant proportion of new building energy needs are to be met via renewable sources has provided a major stimulus to the UK market for Building Integrated PV (BIPV) systems.
- The UK hosts a number of significant players in the field of power generation via photovoltaic (PV) materials.
 - Sharp Electronics UK, the market leader, has its European module assembly plant at Wrexham where capacity is rising to 220 MW per annum.
 - PV Crystalox Solar plc is a global leader in refining silicon ingots for wafer production.
 - ICP Solar Technologies Ltd. has a thin film PV manufacturing facility in Bridgend.
 - G24 Innovations Ltd. has established a dye sensitised solar cell manufacturing facility at Wentloog, Cardiff, with a capacity of up to 200 MW per annum (by the end of 2008).
- There is a growing world-class PV research effort within the UK, with a number of key academic and research institute groups.
- Significant Solar PV research activities are supported by the Engineering and Physical Sciences Research Council's (EPSRC) 'SUPERGEN' Programme and the Technology Strategy Board's Emerging Energy/Low Carbon priority of the Collaborative R&D Programme.

6.6. SWOT Analysis

Table 6.2 below gives a summary of the Strengths, Weaknesses, Threats and Opportunities of the UK's solar PV industry.

<p style="text-align: center;">Strengths</p> <ul style="list-style-type: none"> • Access to a world class, innovative and collaborative R&D community. • A production facility of the world's PV market leader. • A market leader in refining silicon ingots for wafer production. • An international reputation for modern architectural design and in the construction of buildings which integrate environmentally friendly technologies such as PV. • Skills related to the production of PV cells and units in the semiconductor and electronics industries. 	<p style="text-align: center;">Weaknesses</p> <ul style="list-style-type: none"> • Manufacturing processes for PV cells are expensive (labour and capital intensive) • Investment barriers for new entry into the PV cell production market are high. • Relatively low (local) market demand suppresses industry growth. • Expensive PV installations (per Watt of installed capacity) require significant financial support.
<p style="text-align: center;">Opportunities</p> <ul style="list-style-type: none"> • Introduction of breakthrough technology (eg, organic cells) and increased demand could reduce PV unit costs significantly. • Leverage of the UK's capability in electronics. • Low Carbon Buildings and other initiatives could increase PV integration in buildings. • Increasing Government support for micro-generation technologies. • UK and European market expansion could support PV wafer and cell manufacture and increased module assembly. • Growing and relatively unexploited UK market for PV. 	<p style="text-align: center;">Threats</p> <ul style="list-style-type: none"> • Strong competition in PV cell manufacture from companies in Japan, Germany and the US in particular. • Production cost reductions for PV systems not realized. • Transfer of PV cell manufacture to low cost, developing economies; the same applies to potential new production facilities. • Inadequate UK support measures as compared with those offered elsewhere.

Table 6.2 - SWOT analysis for the UK's Solar PV industry.

7. ENERGY FROM BIOMASS / BIOFUELS

7.1. Brief Overview of the UK's Energy from Biomass Landscape

In general, the use of biomass fuels as a renewable energy source in power generation can be carried out in two ways; either through the construction of dedicated biomass plants, or through co-firing of biomass with other fuels in existing power plant. In addition, Landfill Gas (LfG), Energy from (solid) Waste (EfW) and sewage sludge digestion schemes utilise energy from biomass sources.

The co-firing of biomass with coal in the UK represents a major market for imported biomass, and approximately 1.5 million tonnes of biomass was co-fired in the UK in 2005 and over one million tonnes of this biomass was imported (see the International Energy Agency (IEA) Bioenergy Task 40 Report T40UK02R, M. Perry & F. Rosillo-Calle, Imperial College, London, November 2006). Obviously, co-firing is not a standalone technology, and its future is dependent upon the future of fossil fuel power plants – coal in particular. In addition, co-firing is currently encouraged through the Renewables Obligation, but there are constraints on the proportion of an electricity supplier's obligation that can be met from co-firing. The details are as follows:

- Until 31 March 2006 the maximum amount of co-firing eligible for Renewables Obligation Certificates (ROCs) was 25%.
- Falling to 10% from 1 April 2006 until 31 March 2011.
- Falling further to 5% from 1 April 2011 until 31 March 2016 after which co-firing will no longer be eligible for ROCs.

In 2006, approximately 50% of electricity generated from renewable sources was from biofuels (approximately 9.23 TWh of a total of 18.13 TWh) and approximately 2.53 TWh or 27% of this biofuel energy was produced by co-firing biomass with fossil fuels (see BERR's 'Digest of United Kingdom Energy Statistics 2007', <http://www.berr.gov.uk/energy/statistics/publications/dukes/pages39771.html>). Excluding the use of landfill gas, which generated approximately 4.3 TWh of energy in 2006, co-firing is the largest producer of biomass energy in the UK, saving over 3 million tonnes of CO₂ per year.

Energy data (inputs, electricity generated, etc.) for 2005, for a wide range of biofuels are shown in Table 7.1 (from <http://www.biomassenergycentre.org.uk/>).

Biofuel	Energy Input (TWh)	Percentage of renewable energy input (%)	Electricity Produced (TWh)	Percentage of Total Renewable Electricity Generated (%)
Landfill Gas	16.52	33.5	4.29	25.4
Co-firing	9.66	19.6	2.53	15
Waste Combustion	5.35	10.8	0.96	5.7
Domestic Wood	2.37	4.8		
Sewage Gas	2.08	4.2	0.4	2.4
Industrial Wood	0.94	1.9	---	---
Other Biofuels	4.21	4.21	8.5	5.1

Table 7.1 - Data showing the energy inputs and electricity generated using biofuel sources in the UK in 2005 (from: <http://www.biomassenergycentre.org.uk/>).

A very good description of biomass co-firing technology in pulverized fuel power plants is given in a BERR publication: 'Best Practice Brochure: Co-firing of Biomass at UK Power Plant', DBERR/Pub URN 05/1159, August 2005).

UK power plants use direct co-firing, where combustion of the biomass and coal take place in the same boiler, and coal mills can typically handle 10-15% biomass. Thus, existing fossil fuel-fired power stations can relatively quickly be modified for co-firing, although there are issues associated with increased 'fouling' and corrosion in boiler plant, and corrosion and erosion in the hot gas path of gas turbines through the use of biomass fuels. As a result, most UK coal-fired generators have co-fired significant quantities of biomass and the conversion efficiencies when co-firing in large pulverized fuel boilers are relatively high.

A list of coal fired power plants which were co-firing in mid 2005 is shown below in Table 7.2.

Station	Total capacity (MWe)	Generator	Status	Biomass fuels
Aberthaw	1,455	RWE npower	Commercial	Various
Cockenzie	1,200	ScottishPower	Commercial	Wood
Cottam	2,000	EdF	Commercial	Various
Didcot	2,100	RWE npower	Commercial	Wood
Drax	4,000	Drax Power	Commercial	Various
Eggborough	1,960	British Energy	Commercial	Various
Ferrybridge	2,035	Scottish & Southern	Commercial	Various
Fiddler's Ferry	1,995	Scottish & Southern	Commercial	Various
Ironbridge	970	E.ON UK	Commercial	Various
Kingsnorth	2,034	E.ON UK	Commercial	Various
Longannet	2,400	ScottishPower	Commercial	Waste-derived fuel
Ratcliffe	2,010	E.ON UK	Commercial	Various
Rugeley	1,000	International Power	Commercial	Various
Tilbury	1,085	RWE npower	Commercial	Wood
West Burton	1,980	EdF	Trial	Olive cake

Table 7.2 - Biomass co-firing in the UK, as of August 2005 (from: Best Practice Brochure: 'Co-firing of Biomass at UK Power Plant', DBERR/Pub URN 05/1159, August 2005).

Interest in dedicated biomass plants is also increasing, although there are issues with the supply chain for the biomass itself (beyond the scope of this report), and UK technology developers are currently running trials and pilot scale tests in a number of promising biomass utilisation technologies including anaerobic digestion, pyrolysis and gasification (again, descriptions of these technologies are beyond the scope of this report).

Although electricity generation from Landfill Gas schemes makes a significant contribution to the total UK electricity generation from renewable sources (as mentioned above, and see Figure 7.1 below), the most promising sites have already been developed and the average generating capacity of more than 300 sites operational in 2006 was only approximately 2 MW.

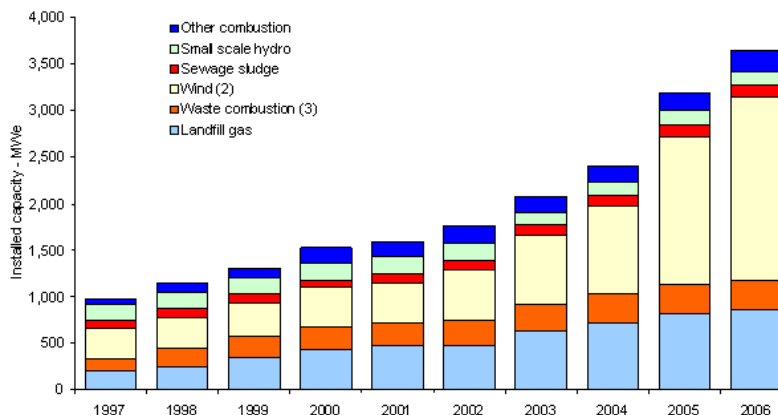

- (1) Large scale hydro capacity was 1,369 MWe in 2006.
 (2) Wind includes both onshore and offshore and also includes solar photovoltaics (9.9 MWe in 2006) and shoreline wave (0.5 MWe in 2006).
 (3) All waste combustion plant is included because both biodegradable and non-biodegradable wastes are burned together in the same plant.

Figure 7.1 – Electricity generation from renewable sources (from ‘Digest of UK Energy Statistics 2007’, BERR).

The same average capacity (approximately 2 MW per facility) also applies to the more than 200 LfG projects commissioned for construction in 2006 and beyond (see ‘Digest of UK Energy Statistics 2007’ BERR). Similarly, the capacity of the sewage gas schemes is only approximately 1 MW per facility. However, for the UK’s municipal and industrial waste (EfW) schemes, the average electricity generating capacity is considerably better at approximately 13 MW per facility (and these are usually CHP schemes).

For reference, a detailed map of the UK’s bioenergy facilities has been published by La Tene Maps in association with the Renewable Energy Association (REA, <http://www.r-p-a.org.uk>), which can be obtained free of charge, in electronic form, from La Tene Maps. It includes:

- Dedicated and co-firing biomass power projects.
- Landfill gas, sewage gas and anaerobic digestion.
- Energy from waste plants.
- Heat only, and Combined Heat and Power (CHP) projects.

7.2. Selected UK Capability in Biomass / Biofuel Power Plant

As mentioned above, the UK’s generators have now gained considerable experience in the co-firing of biomass with pulverised coal. However, there is little information available in the public domain on materials inputs to biomass / biofuel power generation plant, and little information was gathered during the course of this work on the same.

Many of the materials challenges facing power generation via biomass are not technology issues per se, but are instead related to the fuel chain (energy crops). Thus, the technical challenges which are present are largely related to alloy and coating development for the hostile environments of biomass plants, and to some extent may be considered in the same way as materials development for super-critical and ultra super-critical (USC), fossil-fired power plant, at least for biomass combustion.

In this respect, for dedicated biomass plants, UK based companies already have the capability to produce the prime movers (gas engines, gas turbines and steam turbines), which utilise the gas and recovered heat from biomass combustion. In addition, the UK’s leading designer of supercritical coal

plant (Doosan Babcock Energy Ltd.) is carrying out design work which will enable power stations to use up to 50% biomass in pulverised fuel combustion (from: Mott MacDonald Report to UK Trade & Invest, 2007).

In addition, TEI Ltd (Wakefield, W. Yorks) have capability in the mechanical design, supply and fabrication of burners for biofuel combustion, and has installed such burners at Ferrybridge 'C'.

Companies involved in the construction of large biomass boilers include companies such as Metso Corporation (Finland), Aker Kvaerner (Norway) and Binder GmbH (Austria).

Biomass Engineering Ltd. (Newton-le-Willows, Lancs.), supported by the Technology Strategy Board (TSB) in the Combined Heat and Power (CHP) area are investigating the application of a 80 kW downdraft gasifier to a range of waste feedstocks, to assess the effects on the gasification process. Most of the materials used in the gasifiers are relatively simple steels or stainless steels.

Talbotts Biomass Energy Ltd. (Stafford) manufactures biogas boilers, and biomass power and CHP units.

UK based players in power generation from Landfill Gas include:

- Clarke Energy UK Ltd. (Liverpool) is the sole UK distributor for GE Jenbacher gas power generation units (engine, gas handling, generator, exhaust).
- ENER.G Holdings plc (Manchester) has developed a system of portable, modular gas units with outputs ranging from 300kW to 1.15MW.

7.3. Construction of Large Dedicated Biomass Plants in the UK

Two examples of large dedicated biomass fueled power stations, which are either under construction or the final stages of planning, are given below:

E.ON UK plc's Steven's Croft Plant

In January 2006, E.ON UK plc began construction of the UK's largest dedicated biomass power station at Steven's Croft, near Lockerbie, in Scotland, which was expected to become fully operational in December 2007. The 44MW plant will burn a combination of forestry residue and specially grown willow, and is a turnkey contract awarded to a consortium of Aker Kvaerner and Siemens.

Aker Kvaerner Power will supply the power boiler (126 MW), based on a bubbling fluidised bed combustor, the fuel handling system and the flue gas cleaning plant. Aker Kvaerner Engineering Services Ltd. (Stockton-on-Tees) is a UK based subsidiary of Aker Kvaerner ASA (Norway), specialising in Energy from Waste (EfW) and Combined Heat and Power (CHP) plant.

ScottishPower plc's Longannet Plant

Scottish Power has announced that it is to build a 20-25 MW biomass power station at a brown-field site at its Longannet power station in Scotland, which will be operational in 2010. The plant will co-fire Waste Derived Fuel (WDF) with waste wood

7.4. Selected R&D Activities Related to Materials in Biomass Power Generation

As part of the EPSRC's SUPERGEN project, there is a 'Bioenergy Consortium' (see: <http://www.supergen-bioenergy.net/>), which received approximately £2.9M of funding in the first phase of funding (now completed) and has recently been awarded a further £6.4M. The Consortium partners are shown below in Table 7.3 below:

Academic Partners	Invited Industrial Partners	Associate Academic Partners
Aston University	Alstom Power UK Ltd	Irish Seaweed Centre
Cranfield University	AMEC	University of Oxford
Forest Research	Bical	University of Ulster
Institute for Grassland & Environmental Research	Biffa	SAMS (Scottish Association for Marine Science)
Manchester University	Biomass Engineering Ltd	
Policy Studies Institute	BP	
Rothamsted Research	Coppice Resources	
University of Leeds	E.ON UK plc	
University of Sheffield	Johnson Matthey	
Imperial College London	RWE npower plc	
	Rural Generation	

Table 7.3 – Partners in the EPSRC’s SUPERGEN ‘Bioenergy Consortium’.

There are eight main themes in the project, the most relevant of which to materials are ‘Thermal Conversion’ and ‘Power & Heat’, although there are materials aspects to some of the other themes; details of which can be found at the Consortium website – see above for link.

Details of Technology Strategy Board’s (TSB) Technology Programme projects can be found at the TSB database: <http://technologyprogramme.org.uk/site/publicRpts/default.cfm?subcat=publicRpt1>), and a current project relevant to materials in biomass fuel fired power generation is summarized below:

- ‘High Corrosion Resistant Coatings for Biomass Plant (HICOAT)’ is aimed at developing and demonstrating low cost coating technology to increase component reliability, extend plant life and increase operating performance of biomass-fuelled power units. The project runs from July 2006 until July 2008, with a total project cost of approximately £340k, with £170k from the Technology Strategy Board. The project partners are: TWI Ltd. (lead), Talbotts, Independent Power Corp. plc, Monitor Coatings Ltd., Metallisation Ltd. ADAS. Energy Power Resources and Ecka Metal Powders Ltd.

In addition, to the SUPERGEN and Technology Strategy Board Collaborative R&D Programme activities, Cranfield University’s Energy Technology Centre is particularly active in studies of the combustion of biomass fuels and materials degradation (corrosion, erosion, etc.) related to the use of such fuels.

7.5. Summary

The following gives a very brief summary of the status of the UK’s biomass / biofuels energy industry:

- In 2006, there was approximately 1.5 GW of UK installed biofuels capacity, generating a collective 6 TWh of electricity, comprising:
 - Approximately 850 MW of Landfill Gas.
 - Approximately 325 MW of solid municipal waste combustion
 - Approximately 340 MW from other sources such as sewage sludge digestion.
- In addition, approximately 2.5 TWh of electricity was generated through biomass co-firing at pulverised coal fired power plant.

- Most UK coal-fired generators have co-fired significant quantities of biomass in large pulverized fuel boilers.
- Although electricity generation from Landfill Gas schemes makes a significant contribution to the total UK electricity generation from renewable sources, the most promising sites have already been developed and the average generating capacity per site is only approximately 2 MW.
- UK based companies are active in advanced biomass (energy) conversion technologies including anaerobic digestion, pyrolysis and gasification.
- UK based companies and universities are active in materials and coatings development for biomass power plant applications.
- The materials issues associated with biomass co-firing relate to ‘fouling’ and corrosion / erosion in boilers and gas turbines.

7.6. SWOT Analysis

Table 7.4 below gives a summary of the Strengths, Weaknesses, Threats and Opportunities of the UK’s energy from biomass industry, with emphasis on biomass equipment / plant:

<p style="text-align: center;">Strengths</p> <ul style="list-style-type: none"> • The UK has a strong capability in services supporting all stages of dedicated biomass and biomass co-firing project life. • There is also strength in manufacturing bulk handling and balance of plant equipment. • There are a number of companies manufacturing small biomass boilers for use in niche markets from domestic to small industrial scale. • There is activity in R&D for advanced conversion technologies. • Current biomass technology design is mature with some bespoke elements to the combustion systems. 	<p style="text-align: center;">Weaknesses</p> <ul style="list-style-type: none"> • No relatively large scale biomass boiler manufacturers. • Costs of biomass plants (both waste and energy crops) are high due to the nature of the fuel. Biomass fuel requires specific combustion technology and a reliable biomass fuel supply. • At present, the fuel supply chain for energy crops is not well developed in the UK.
<p style="text-align: center;">Opportunities</p> <ul style="list-style-type: none"> • The UK may be able to become a key player in advanced conversion technology and obtain the benefits from the associated supply chain. • UK’s strength in services, bulk handling and balance of plant represents an opportunity for export. 	<p style="text-align: center;">Threats</p> <ul style="list-style-type: none"> • Uncertainty over the future market size could threaten investment decisions. • There is strong and consolidated international competition for the supply of large equipment items. • Development of advanced conversion technology outside the UK could displace UK providers.

Table 7.4 - SWOT analysis for the UK’s power generation from biomass industry.

8. FUEL CELLS

8.1. The Market Opportunity for Energy from Fuel Cells

For completeness, this section provides some basic information on the status of Fuel Cell development in the UK and some links are provided to more detailed sources of information.

Currently, more than one hundred UK based companies are active in the development of fuel cell technologies, from materials R&D to fuel cell systems integration. UK based companies in the sector are developing their supply chains as their technologies evolve. Some, for example, Johnson Matthey plc, are working closely with UK partners to build UK based supply chains.

It is also clear that the UK's materials R&D (both industrial and academic) is at the forefront of fuel cell technology, and will continue to be so for the foreseeable future. From a technical viewpoint, the UK's particular strengths lie in PEM (proton exchange membrane) and Solid Oxide Fuel Cell (SOFC) materials, components and systems, as well as stationary reformer systems, fuel delivery and storage systems, and systems for thermal management relating to 'balance of plant'.

Fuel cell markets worldwide are in the early stages of commercialisation, in both stationary (small- or large-scale) and transport applications. There is a growing number of large scale demonstration activities across the world; for example, by the end of 2006, Japan's national programme included over 1,200 stationary fuel cells. Alongside niche applications, leading players are looking to release commercial products soon; for example, Honda has announced plans to put its fuel cell vehicle into mass production and on sale within the next year.

With the interest in distributed power, fuel cells are well suited to support power generation or combined heat and power generation (CHP) using either natural gas or renewable fuels, and UK fuel cell developers include established power generation equipment companies, as well as smaller specialist companies originating in the fields of materials science and/or chemistry.

The UK has an extremely strong academic research base in materials, chemistry and engineering relevant to fuel cell systems development. There are particular strengths in SOFC research and development, with around ten groups working on various aspects across the academic base, including: Universities of Bath, Birmingham, Dundee, Imperial College, Keele, Loughborough, Manchester, Queen Mary College, Sheffield, St. Andrews and Surrey.

The UK has several companies active in the development of Solid Oxide Fuel Cell (SOFC) systems. Key players include Rolls-Royce (Rolls-Royce Fuel Cell Systems, RRFCS, Ltd.), Ceramic Fuel Cell System Ltd. and Ceres Power, and in Proton Exchange Membrane Fuel Cells (PEMFC), including Intelligent Energy and Voller Energy. There are also strengths in the supply of components and materials, and Johnson-Matthey is a world leader in the supply of membrane electrode assemblies (MEAs) and catalysts, supplying approximately one third of all MEAs world-wide.

Mass commercialisation is, in many instances, being preceded by deployment in niche applications, where the benefits of fuel cells are particularly valued. For mass deployment in distributed power and/or the large combined heat and power (CHP) markets, fuel cell technologies (and hybrid systems with gas turbines) need to be shown to be both cost competitive and reliable. Fuel Cells in stationary applications are not expected to replace large power stations, but could instead form a significant part of a distributed power generation network.

8.2. Resources for Fuel Cell Technologies & UK Capability

The materials supply chains for most fuel cell technologies are somewhat immature, although in Johnson Matthey, the UK is home to a world leader in catalysts and catalysed components for fuel cells, and there are a number of other world-leading developers.

In light of the existence of a number of recent excellent review articles, a detailed description of fuel cell technologies and their application has not been included in this report. Rather the reader is directed to a number of excellent public sources, including the 'Fuel Cell Today' website: <http://www.fuelcelltoday.com/>), where reviews such as the '2007 Large Stationary Survey' can be found and the 'Fuel Cells UK' website (<http://www.fuelcellsuk.org/>), which hosts a guide to UK fuel cell capability ('The UK Fuel Cell Industry: A Capabilities Guide 2004', (http://www.fuelcellsuk.org/team/Library/Fuel_Cells_UK_Research_Capability_Guide_2004.pdf)), which has very recently been partially updated (see 'UK Fuel Cell Capabilities, Fuel Cells UK, 2007') and contains a presentation on fuel cell materials, applications and development trends (http://www.fuelcellsuk.org/team/Library/FuelCellsUK_Introduction_to_FCs.pdf).

In addition, although a little out of date the 'UK Fuel Cell Development and Deployment Roadmap 2005' (http://www.fuelcellsuk.org/team/Library/Roadmap-Fuel_Cells_UK-final.pdf) gives an excellent overview of:

- Fuel cell activities in the UK.
- UK fuel cell strengths.
- UK fuel cell focus.
- Challenges facing the UK, and strategies and actions to overcome them.
- UK organisations active along the fuel cell supply chain.
- Levels of global industrial activity along the fuel cell supply chain.

As regards UK Fuel Cells R&D (although by no means exhaustive), information can be found on activities which are in the public domain at the following sites:

- BERR's 'Hydrogen, Fuel Cells and Carbon Abatement Technologies Demonstration (HFCCAT) Programme' (<http://www.hfccat-demo.org/>).
- The Technology Strategy Board (TSB) Collaborative R&D Programme in the TSB's searchable project database: Details of Technology Strategy Board Collaborative R&D Programme projects can be found at the searchable projects database: <http://technologyprogramme.org.uk/site/publicRpts/default.cfm?subcat=publicRpt1>).
- Information on the EPSRC's SUPERGEN 'Fuel Cells Consortium' can be found at: <http://www.supergenfuelcells.co.uk/>). Consortium partners are Imperial College London, University of Newcastle, University of Nottingham, University of St Andrews, Ceres Power Ltd, Defence Science and Technology Laboratory, Johnson Matthey plc and Rolls-Royce Fuel Cell Systems (RRFCS) Ltd.
- An extensive list of 'Fuel Cells' (and Hydrogen) R&D activities can be searched at the UK Energy Research Centre (UKERC) Research Atlas (specifically the Research Register) (<http://ukerc.rl.ac.uk/ERA001.html>).

8.3. Summary

The following gives a very brief summary of the status of the UK's fuel cells industry, but the reader should refer to sources such as the 'UK Fuel Cell Development and Deployment Roadmap 2005' (http://www.fuelcellsuk.org/team/Library/Roadmap-Fuel_Cells_UK-final.pdf) for further information.

- There are more than one hundred UK based companies are active in the development of fuel cell technologies, from materials R&D to fuel cell systems integration.
- Fuel cells are well suited to support distributed power generation or combined heat and power generation (CHP) using either natural gas or renewable fuels.
- Fuel cells are proving competitive in niche applications, and production scale-up will help to accelerate the cost reduction necessary for mass commercialisation.

- The UK has particular strengths in PEM (proton exchange membrane) and Solid Oxide Fuel Cell (SOFC) materials, components and systems, as well as stationary reformer systems, fuel delivery and storage systems, and systems for thermal management relating to 'balance of plant'
- The UK's fuel cell materials R&D (both industrial and academic) is at the forefront of fuel cell technology and the UK has an extremely strong academic research base in materials, chemistry and engineering relevant to fuel cell systems development, with more than 35 active university based research groups.
- The UK has several companies active in the development of Solid Oxide Fuel Cell (SOFC) systems (eg, Rolls-Royce Fuel Cell Systems, RRFCS, Ltd., and Ceres Power), and in Proton Exchange Membrane Fuel Cells (PEMFC) (eg, Intelligent Energy and Voller Energy).
- There are also strengths in the supply of components and materials, and Johnson-Matthey is a world leader in the supply of Membrane Electrode Assemblies (MEAs) and catalysts, supplying approximately one third of all MEAs world-wide.
- However, in addition to systems cost, there are a number of issues related to materials durability/performance, which have yet to be overcome.

8.4. SWOT Analysis

Table 8.1 below gives a (not exhaustive) summary of the Strengths, Weaknesses, Threats and Opportunities of the UK's fuel cells industry, but again the reader should refer to the sources of information given above for further details:

<p style="text-align: center;">Strengths</p> <ul style="list-style-type: none"> • UK has considerable expertise in materials and catalyst technology for fuel cells and reformers. • Expertise in the design of fuel cell stacks and the 'balance of plant for stationary applications. • Capabilities in system design, packaging and systems integration, and production engineering. • World class research teams in UK Universities, with world-class expertise in key areas such as materials and catalysis. • World class development teams within industrial organisations. • Attractiveness of AIM as the market of choice for fuel cell companies looking for listings. 	<p style="text-align: center;">Weaknesses</p> <ul style="list-style-type: none"> • Costs of stacks. • Durability/performance levels for stacks. • Relatively low level of Government support, with potential to impact on international competitiveness.
<p style="text-align: center;">Opportunities</p> <ul style="list-style-type: none"> • Opportunities in the design, manufacture, installation and maintenance of fuel cell systems, particularly for stationary power and CHP applications. • Continued materials development for fuel cell systems. • Government support for shift to distributed generation framework (especially if it includes export reward). • Government uptake of forward commitment to buy policies. 	<p style="text-align: center;">Threats</p> <ul style="list-style-type: none"> • Lack of market pull. • Barriers to distributed power generation. • Inability to achieve acceptable cost levels for stacks. • Inability to develop affordable balance of plant. • Inbalance in support / incentive frameworks, which inhibit the ability of fuel cells to compete with, for example, renewable technologies (need for replacement of ROCs with 'low carbon obligation certificates').

Table 8.1 - SWOT analysis for the UK's power generation from fuel cells.

ACKNOWLEDGEMENTS

The author wishes to thank the following organisations, which provided information for this report:

AETC Ltd.
Alcan Aluminium UK Ltd.
Alcoa Howmet Ltd.
Alstom Power Ltd.
Ansaldo SpA
Aqua Energy Group Ltd.
Areva NP
Aston University
ATI Allvac Inc.
Atomic Energy of Canada Ltd. (AECL)
Aubert and Duval (UK) Ltd.
Bangor University
BP plc
Bracken Ltd.
British Energy plc
British Stainless Steel Association
British Wind Energy Association (BWEA)
Brookhouse Composites Ltd.
BTM Consult ApS
BVG Associates Ltd.
Corus UK Ltd.
Coupe Foundry Ltd.
Cranfield University
Department of Business, Enterprise and Regulatory Reform (BERR)
Doncasters plc
Doosan Babcock Energy Ltd.
E.ON UK plc
Engineering and Physical Sciences Research Council (EPSRC)
Fibreforce Composites Ltd.
Firth Rixson Ltd.
Formax UK Ltd.
Fothergill Engineering Ltd.
Fuel Cells UK
Goodwin Steel Castings Ltd.
Gurit UK Ltd.
Harviglass GRP Ltd.
HC Starck Ltd.
Hytemp Nickel Alloys Ltd.
IOM3
Imperial College of Science, Technology & Medicine, London
Independent Forgings and Alloys (IFA) Ltd.
Japan Steel Works (JSW)
Johnson Matthey plc
Ladish Corp. Inc.
Loughborough University
Magnox Electric Ltd.
Mannesmann DMV Stainless (UK) Ltd.
Marine Current Turbines Ltd.
Metrode Products Ltd.
Monitor Coatings Ltd.
National Physical Laboratory (NPL Management Ltd.)
New and Renewable Energy Centre (NaREC)
Nexia Solutions Ltd.
Nuclear Industry Association
Ocean Power Technologies Ltd.
Office of National Statistics (ONS)
OpenHydro Group plc
Osborn Metals Ltd.
Outokumpu Stainless Ltd.
Pelamis Wave Power Ltd.
PowdermatriX
Praxair Surface Technologies Ltd.
Production Glasfibre Ltd.
PV Crystalox Solar plc
Queen Mary College, University of London
QinetiQ Ltd.
Rolls Royce Fuel Cell Systems (RRFCS) Ltd.
Rolls-Royce plc
RWE npower plc
Sandvik Ltd.
Scottish & Southern Energy plc
Scottish Enterprise Energy Team
ScottishPower plc
Sermatech Ltd.
Sheffield Forgemasters Ltd.
Siemens Industrial Turbomachinery Ltd.
Siemens Power Generation Ltd.
Solent Composites Systems Ltd.
Special Metals Wiggin Ltd
Sulzer Metco UK Ltd.
Sumitomo Metal Industries Ltd.
TEI Greens Overseas Ltd.
TIMET UK Ltd.
Turbomach SA
TWI Ltd.
UK Steel
UK Trade and Investment (UKTI)
University of Birmingham
University of Bristol
University of Cambridge
University of Manchester
University of Oxford
University of Plymouth
University of Sheffield
Vallourec & Mannesmann UK Ltd.
Vestas Blades UK Ltd.
Vestas Towers Ltd.
Wave Dragon Wales Ltd.
Wavegen (Applied Research & Technology Ltd.)
WindSupply
Wyman-Gordon Ltd.
Yorkshire Forward